

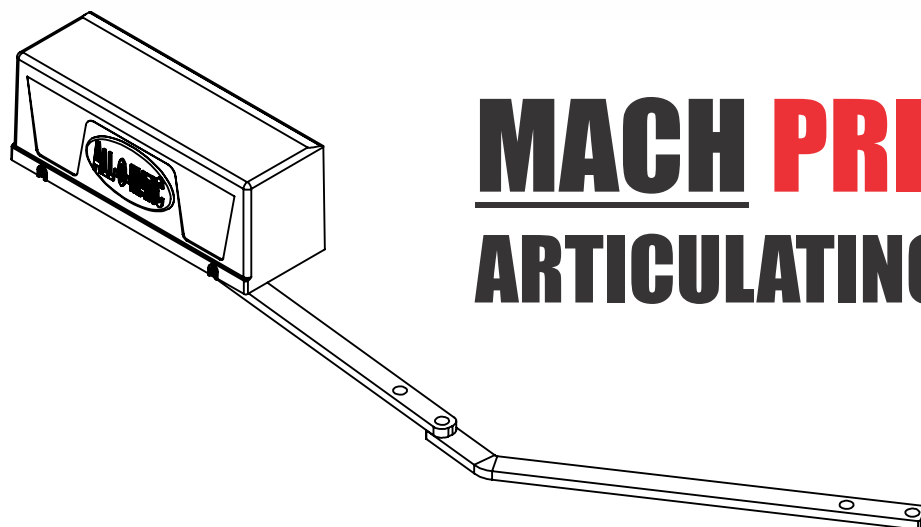

# ALL-O-MATIC



## MACH PRIME ARTICULATING ARM

## TORO 24 PRIME actuator

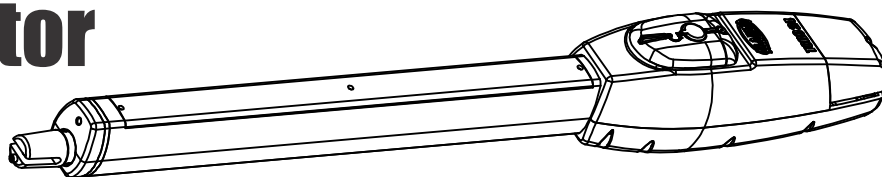

# SWING GATE OPENERS

# INSTALLATION MANUAL



Compliant

UL325  
Compliant

UL991  
Compliant

Canada  
CSA C22.2  
Compliant



## TABLE OF CONTENTS

• IMPORTANT SAFETY INSTRUCTIONS.....	1-2
• DIFFERENT UL 325 CLASS TYPES.....	3
• TECHNICAL DATA.....	4
• PARTS IDENTIFICATION TORO24 PRIME.....	5
• PARTS IDENTIFICATION MACH-PRIME.....	6
• OPEN INSIDE INSTALLATION TORO24 PRIME.....	7
• OPEN OUTSIDE INSTALLATION TORO24 PRIME.....	8
• GATE OPERATOR INSTALLATION TORO24 PRIME.....	9-11
• MOTOR WIRING TORO24 PRIME .....	10
• EMERGENCY RELEASE TORO24 PRIME.....	11
• LIMIT SWITCH ADJUSTMENT TORO24 PRIME.....	11
• GATE OPERATOR INSTALLATION MACH-PRIME.....	12-16
• EMERGENCY RELEASE MACH-PRIME.....	14
• MOTOR WIRING MACH-PRIME .....	15
• LIMIT SWITCH ADJUSTMENT MACH-PRIME.....	16
• LCD DISPLAY SETTINGS AND PROGRAMMING.....	17-18
• LCD DIAGNOSTICS.....	18
• LCD MENU DESCRIPTION.....	18
• ELECTRICAL CONNECTION.....	19
• SWING GATE LOOP LAYOUT.....	20
• GENERAL LOOP INSTALLATION GUIDELINES.....	21
• ENTRAPMENT PROTECTION INSTALLATION.....	22
• ENTRAPMENT PROTECTION DEVICE CONNECTIONS.....	23-25
• <u>AOM-RED EYE</u> (PHOTOELECTRIC EYE SENSOR).....	24
• ACCESSORY CONNECTIONS.....	26
• LPR-2 LOOP RACK PRIME-VD1 INSTALLATION.....	27
• THREE BUTTON STATION SYSTEM.....	28
• MAGNETIC/SOLENOID LOCK CONNECTION.....	29
• RADIO RECEIVER CONNECTIONS.....	30
• OPEN AND CLOSE OBSTRUCTION SENSITIVITY ADJUSTMENT (ERD) .....	30
• TIMER ADJUSTMENT.....	31
• DIP SWITCH FUNCTIONS.....	32
• SOLAR PANEL CONNECTIONS.....	33
• LED DIAGNOSTICS.....	34
• OPERATOR CURRENT DRAW & VOLTAGE DROP CHARTS.....	35
• OPERATOR PARTS DIAGRAM.....	36-39

# **IMPORTANT SAFETY INSTRUCTIONS**

## **WARNING**

### **To reduce the risk of injury:**

**READ THE FOLLOWING DIRECTIONS. DO NOT START UNTIL YOU HAVE READ AND UNDERSTAND THESE DIRECTIONS. IF THERE IS SOMETHING YOU DON'T UNDERSTAND CALL US.**

**Never let children operate or play with gate controls. Keep the remote control away from children.**

**Always keep people and objects away from the gate. No one should cross the path of the moving gate.**

**This operator must be tested monthly. The gate must reverse on contact with a ridged object or stop when an object activates the non-contact sensors. After adjusting the force or the limit travel, retest the gate operator. Failure to adjust and retest the gate operator properly can increase the risk of injury.**

**Use the emergency release only when the gate is not moving.**

**Keep gates properly maintained. Have a qualified service person make repairs to gate hardware. It takes many years of experience to make proper adjustments to gate hardware or operators.**

**This entrance is for vehicles only. Pedestrian must use separate entrance.**

**There is nothing on a gate operator that is easily repaired without a great deal of experience. Save yourself some time and call a qualified Gate Service Contractor who knows your type of gate operator.**

## **SAVE THESE INSTRUCTIONS FOR FUTURE REFERENCE**

# **INSTALL THE GATE OPERATOR ONLY WHEN YOU HAVE READ THE FOLLOWING:**

- \* **Confirm that the gate operator being installed is appropriate for the application.**
- \* **Confirm that the gate is designed and built according to current published industry standards.**
- \* **Confirm that all appropriate safety features and safety accessory devices are being incorporated, including both primary and secondary entrapment protection devices.**
- \* **Make sure that the gate works freely before installing the operator.**
- \* **Repair or service worn or damaged gate hardware before installation of the gate operator.**
- \* **Eliminate all gaps in a swinging gate below a 4 foot height that permits a 4 inch sphere to pass through any location, including the hinge area of the gate.**
- \* **Operator must be disconnected from the power source before attempting any installation of accessories.**
- \* **Install this gate operator according to our installation instructions.**
- \* **Adjust the operator load sensing device to the minimum force setting that will still allow for reliable gate operation.**
- \* **Install the operator inside the fence line (do not install the operator on the public side of the fence line).**
- \* **Install a proper electrical ground to a gate operator.**
- \* **Controls intended for user activation must be located at least six feet (6') away from any moving part of the gate and where the user is prevented from reaching over, under, around or through the gate to operate the controls. Outdoor or easily accessible controls shall have a security feature to prevent unauthorized use.**
- \* **The stop and/or reset buttons must be located in the line of sight of the gate. Activation of the reset control shall not cause the operator to start.**
- \* **Install a minimum of two(2) WARNING SIGNS, one on each side of the gate where easily visible and take pictures of installation.**
- \* **Test all safety features for proper function before placing the automatic vehicular gate into service.**
- \* **Train owner/users about basic functions and safety features of the gates system, including how to turn off the power and how to operate the manual disconnect feature.**
- \* **leave safety instructions, product literature and installation manual with end user.**
- \* **Explain to the owner/user the importance of routine service and retesting on a monthly basis.**

# DIFFERENT UL 325 CLASS TYPES

## **Class one: Residential**

A vehicular gate operator intended for use at a home of one to four single family dwellings, garage or parking area.

## **Class two: Commercial or General Public Access**

A Vehicular gate operator intended for use at a commercial location or building such as a multi-family housing unit (five or more single family units), hotel, garages, retail stores, other buildings servicing the general public.

## **Class three: Industrial or limited access**

A vehicular gate operator intended for use at an industrial location or building such us a factory, loading dock area, or other locations not intended to service the general public.

## **Class four: Restricted Access**

A vehicular gate operator intended for use at a guarded industrial location or building such as airport security areas or other restricted access locations not servicing the general public where unauthorized access is prevented via supervision by security personnel.

## **Other components required to satisfy UL 325**

Each class must have a primary and secondary means to sense and react to obstructions within two seconds.

## **The six types of obstruction sensing systems are:**

### **Type A:**

Inherent obstruction sensing system. This system must sense and initiate the reverse of the gate within two seconds of contact with a solid object.

### **Type B1:**

Provision for connection of a non-contact device can be used, such as a secondary protection.

### **Type B2:**

Provision for connection of a contact sensor. Examples include an edge device or equivalent. This can be used for secondary protection.

### **Type C:**

Inherent adjustment clutch or pressure relief valve.

### **Type D:**

Provision for connection of or provided with and actuation device requiring continuous pressure.

# TECHNICAL DATA

	TORO24 <b>PRIME</b>	MACH <b>PRIME</b>
<b>Power supply</b>	24VDC	24VDC
<b>Current draw</b>	5 A	6 A
<b>Opening time</b>	14-25 s / 90°	13-24 s / 90°
<b>Duty cycle</b>	50%	50%
<b>Temperature</b>	-20° F to 130° F	-20° F to 130° F
<b>Protection</b>	Ip54	Ip54
<b>Control board</b>	ALL-ACTR PRIME	ALL-ACTR PRIME

**Applications**  
 ft = leaf width  
 lbs = leaf weight

 Recommended dimensions

 Maximum dimensions

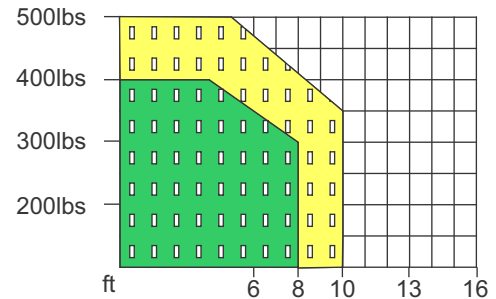
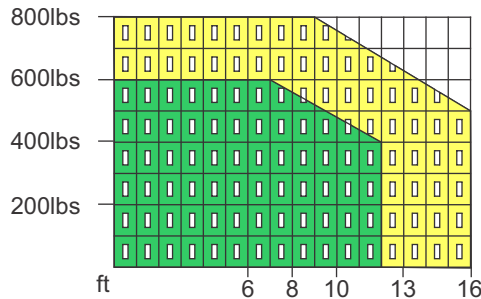

## Operating instructions

For high traffic applications, consider the following.

- Performance characteristics shall be understood as referring to the recommended weight and length of the gate. When used with maximum allowable weight and dimensions, a reduction in the above mentioned performance can be expected.
- Performance was tested on average operating conditions and are therefore not necessarily applicable to specific conditions of use.
- Each automatic entrance has variable elements such as: friction, balancing and environmental factors, all of which may substantially alter the performance characteristics of the automatic gate operator or reduce its working life or parts thereof. The installer should consider each application and make sure the gate conditions are suitable to use the gate operators.

# PARTS IDENTIFICATION TORO 24 PRIME

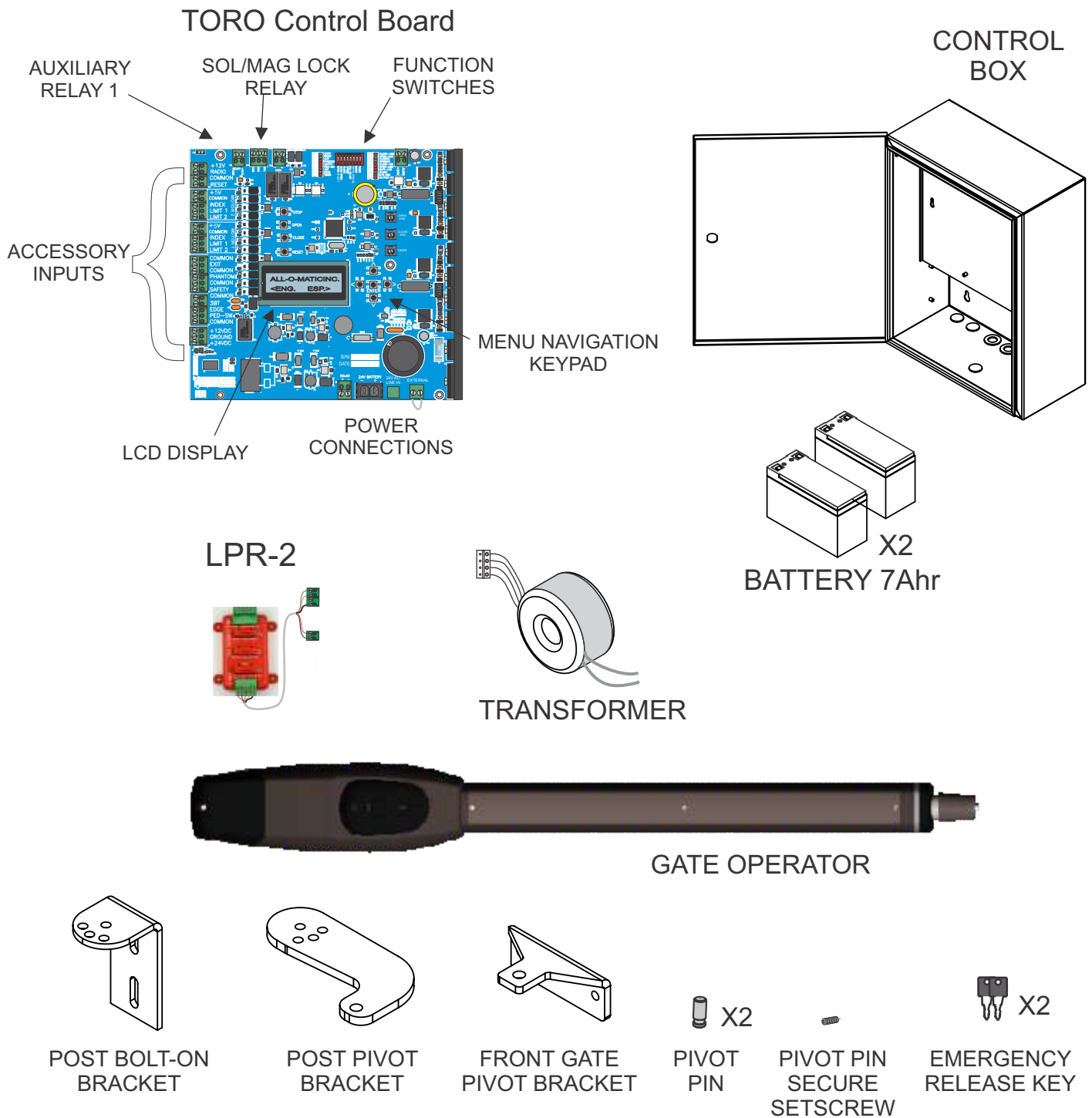

**NOTE: New bolt-on mounting bracket could also be welded for a stronger pivot. For windy areas, it is recommended to weld the post pivot brackets to add rigidity.**



# PARTS IDENTIFICATION MACH PRIME

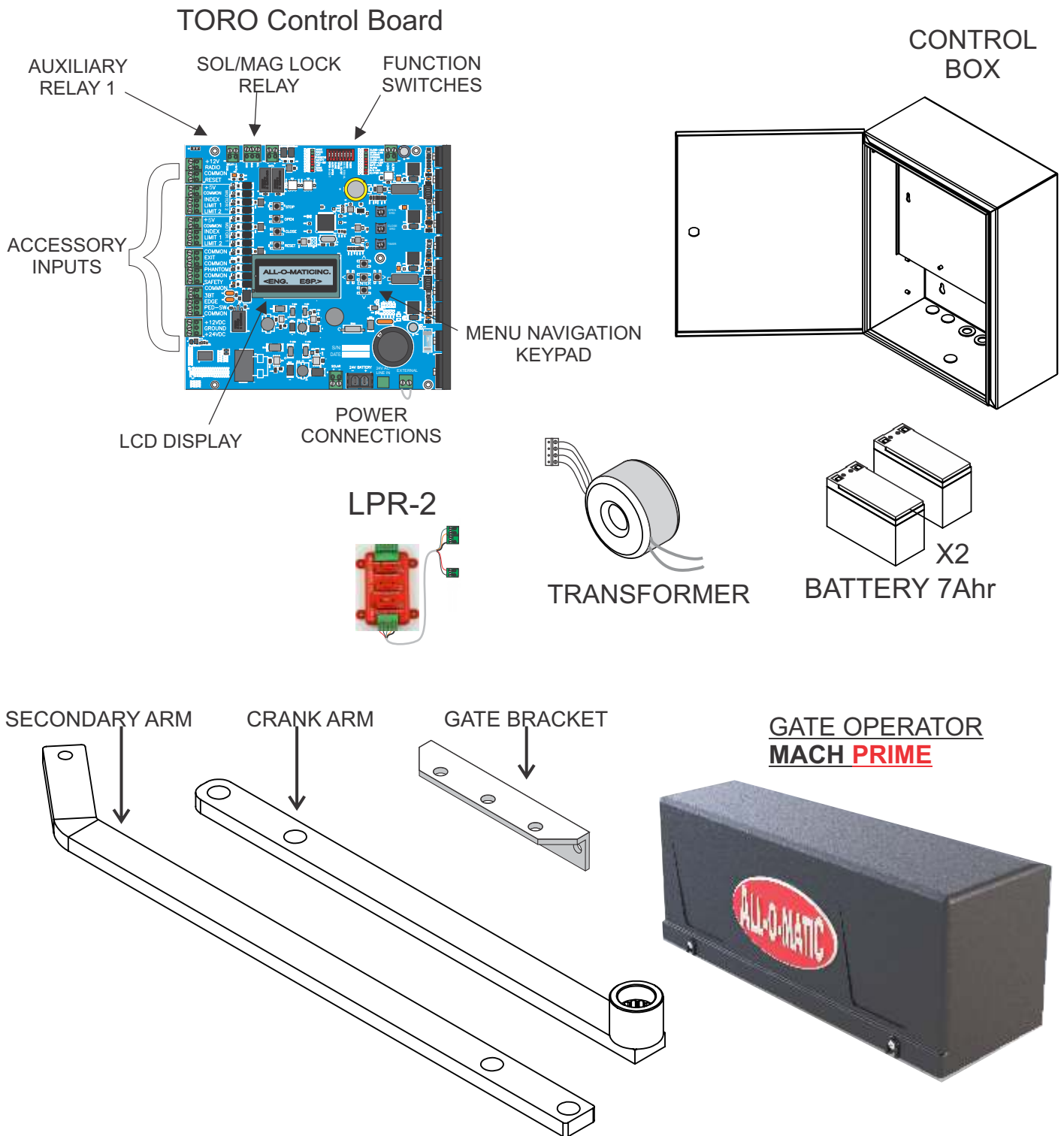

NOTE: A bolt-on gate bracket is available for gates that don't have a cross bar to mount gate bracket. This bolt-on bracket is 20" long and will go across several pickets and decrease the stress on pickets.

# TORO24 PRIME OPEN IN INSTALLATION

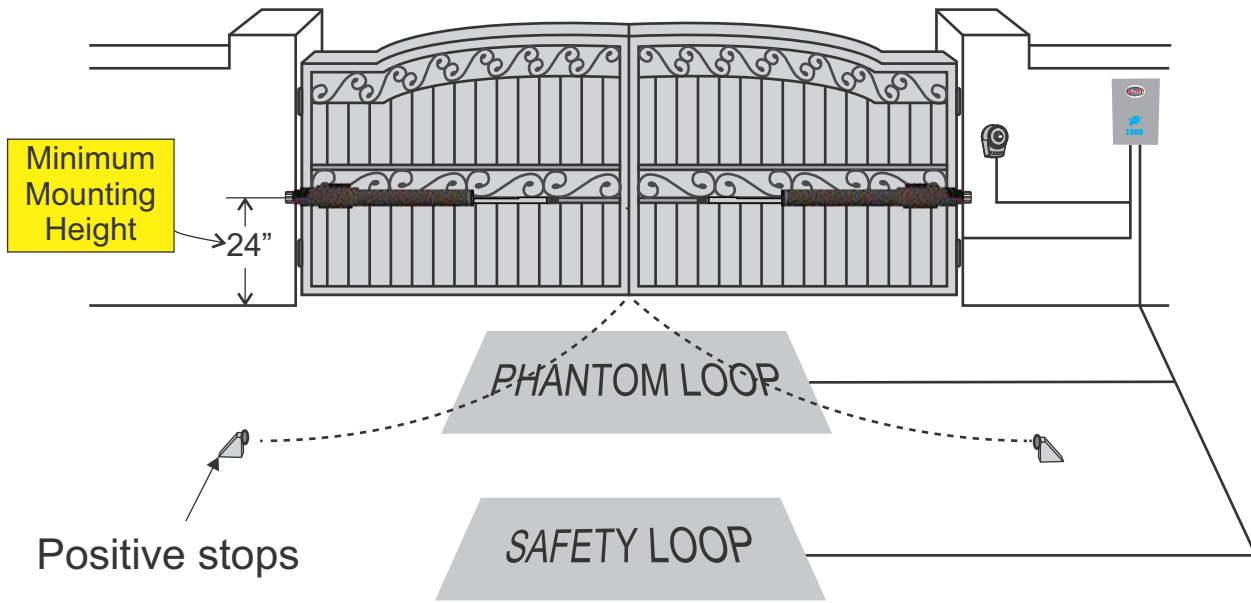

Comply with the measurements shown for proper installation. Adjust the gate structure to optimize for best automation performance, if necessary.

Before proceeding with installation, be sure that gate moves freely and the following:

- 1) Hinges are properly positioned and lubricated.
- 2) No obstructions are in the path of the swinging gate.
- 3) No frictions between two leaves or with the ground while moving.
- 4) **Operator must be mounted 24" above ground or higher.**

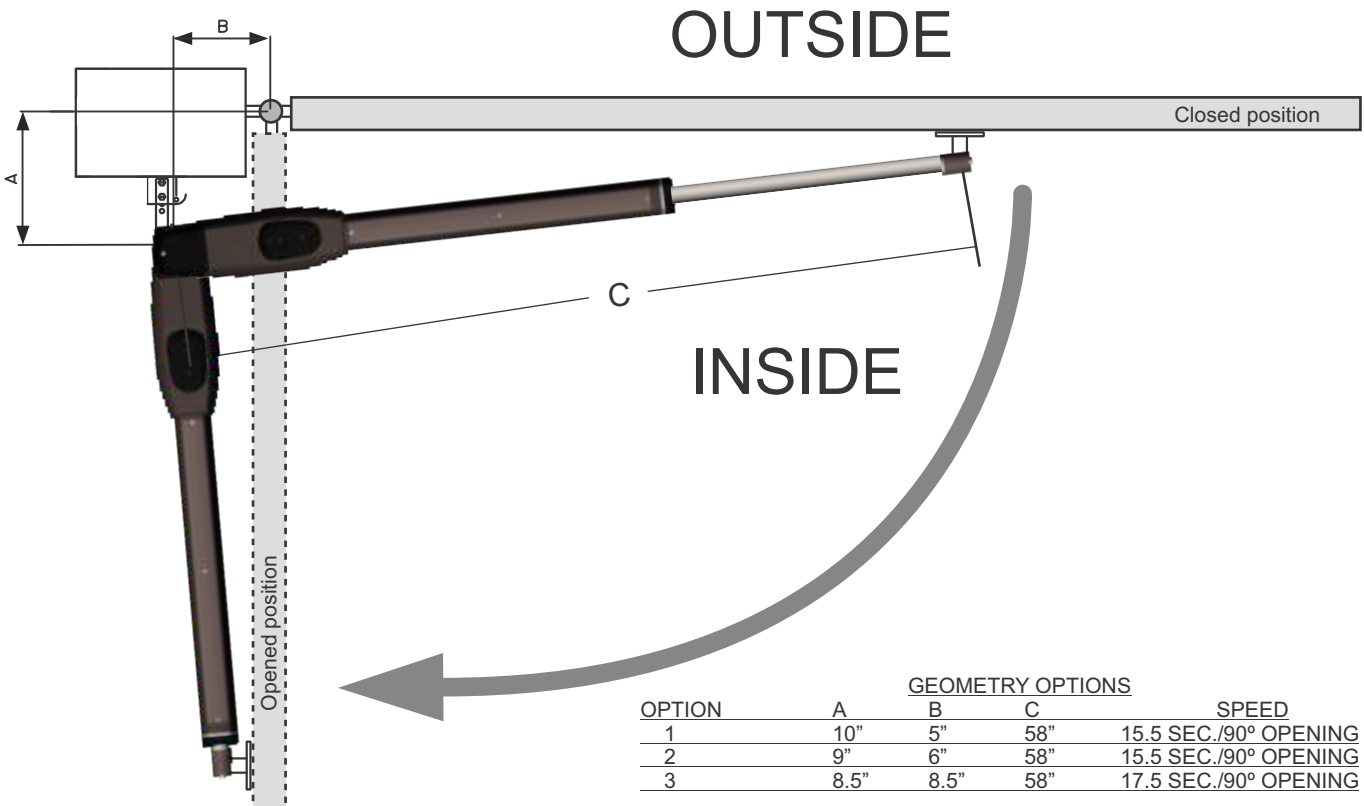

# TORO24 PRIME OPEN OUT INSTALLATION

Comply with the measurements shown for proper installation. Adjust the gate structure to optimize for best automation performance, if necessary.

Before proceeding with installation, be sure that gate moves freely and that:

- 1) Hinges are properly positioned and lubricated.
- 2) No obstructions are in the path of the swinging gate.
- 3) No frictions between two leaves or with the ground while moving.

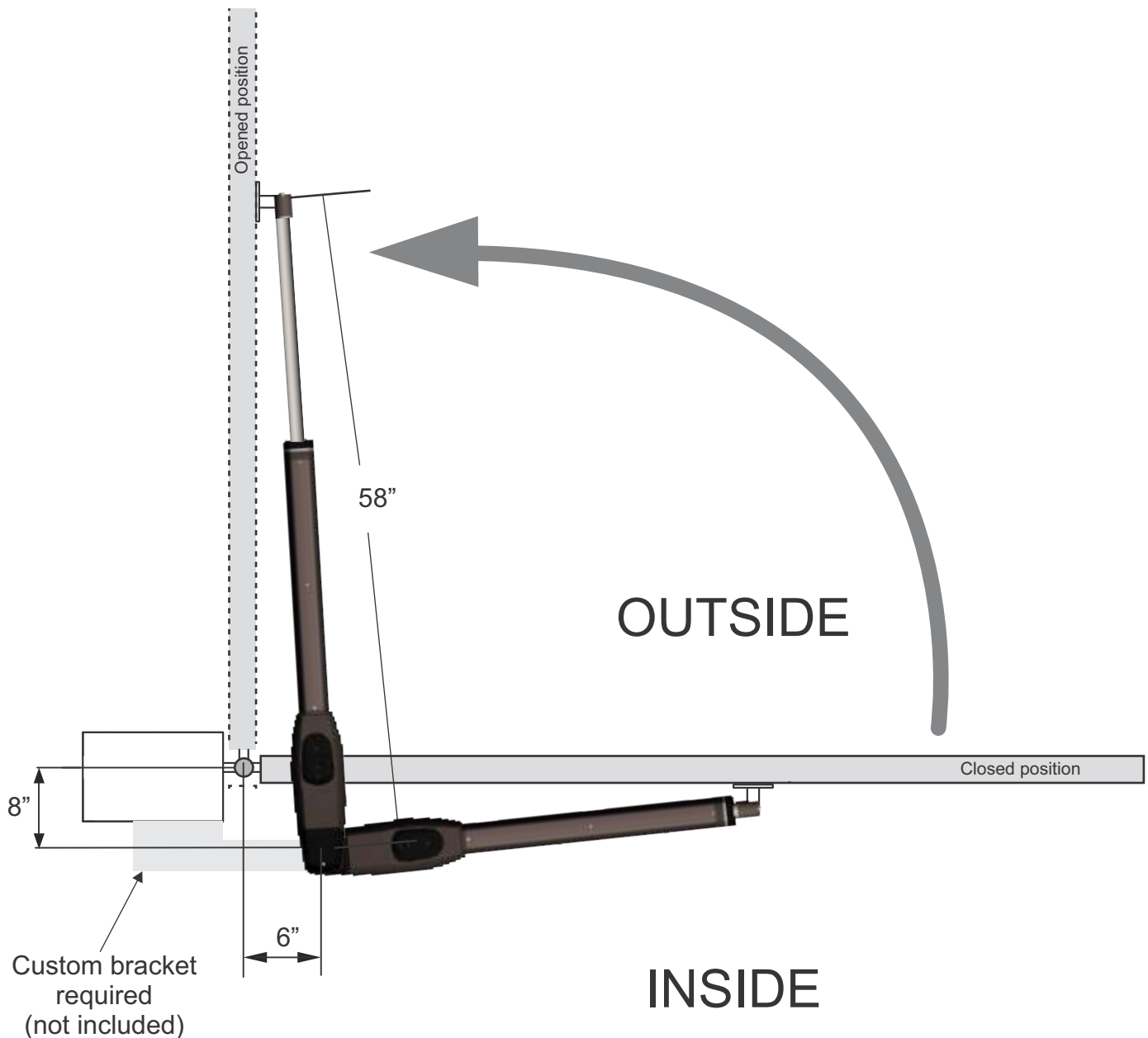

# TORO24 PRIME INSTALLATION

After determining the type of installation, it is important to thoroughly check the following aspects to ensure a proper installation and prevent any potential damage to the gate or gate operator.

- Verify that the gate is aligned properly with the gate post, hinges and other components. Misalignment can cause strain on the gate and its components, leading to premature wear and tear.
- Ensure that there is adequate clearance between the gate and the surrounding structures, such as walls, fences or other gates. Insufficient clearance can result in the gate binding or getting stuck, which may damage the gate, gate operator or surrounding structures.
- Check that the gate is level horizontally and vertically. Uneven or sloping surface can affect the gate's performance and cause unnecessary stress on the gate and gate operator components.
- Inspect the hinges and lubricate them if necessary.

When installing the actuator onto the post and gate, it is important to avoid mounting it on the bottom frame of the gate. Mounting it too close to the ground increases the risk of damage from flooding and can also make it more challenging to make the adjustment and service it.

## WARNING:

Warranty is voided if mounted below 24" off the ground.

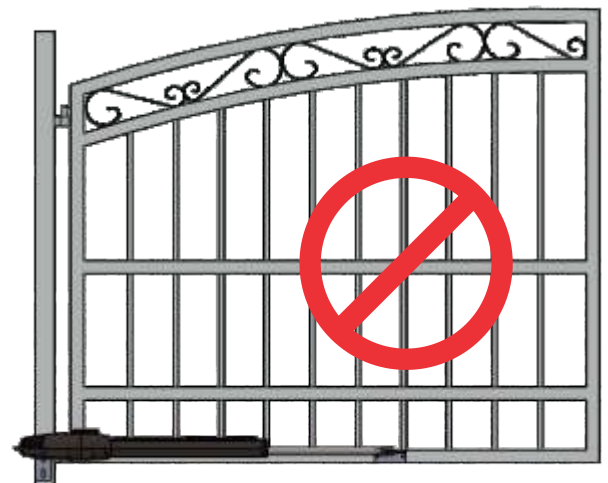

**It is important to install the actuator at least 24" above ground.** To achieve this, it might be necessary to add a brace across the gate to avoid bending vertical pickets. If the gate does not have a bar across the height where the actuator can be safely mounted away from the ground, add the brace to add support to the vertical pickets. Be sure to mount the pivot brackets in a way to keep the actuator level.



# TORO24 PRIME OPERATOR INSTALLATIONS

When a steel post is not available mount the bracket on the column surface.

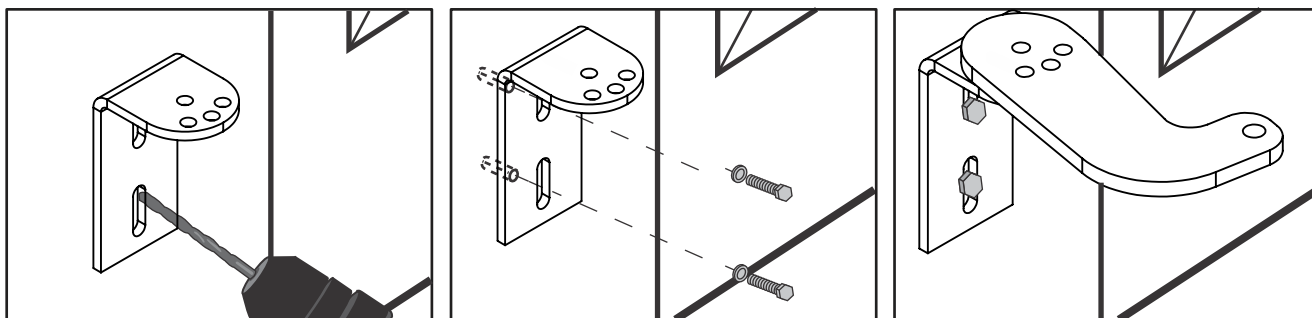

Mount the **post bolt-on** bracket to the pillar/column using anchor bolts if a steel post is not available. Bolt the **Pivot bracket** to fit the geometry. Weld **brackets** if installation site is in a windy area. NOTE: For push to open installation a custom mounting plate(not provided) is required to fit geometry.

Remove the wire connection cover and attach the post pivot bracket with the pin. Release the gate operator and place the pin into the fitting position no. 1 and no. 2 shown below. Use the setscrew to hold pin no. 2 in position.

Make sure the gate operators are mounted in horizontal position especially in the CLOSE, OPEN and 45° positions.

Prior to welding the front gate bracket on the gate leaf(if necessary), cover the gate operator to prevent damage from welding sparks.

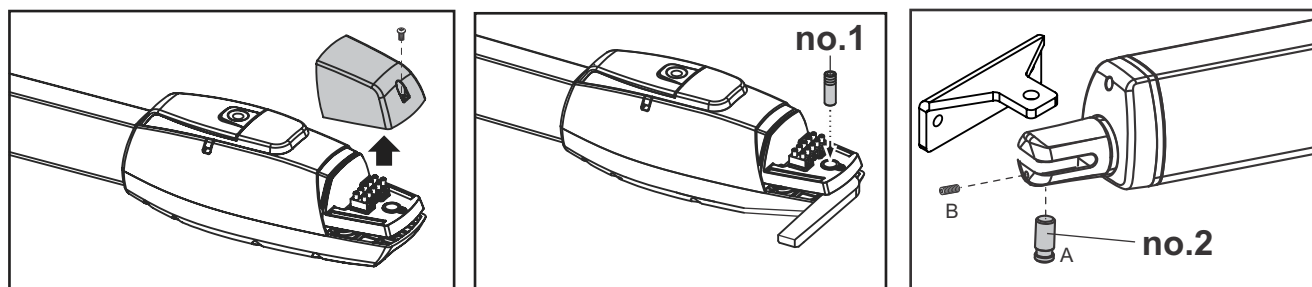

1. Avoid tension in the cable during open and close cycles.

2. Always connect ground wire to GND.

3. Pay close attention to the motor connectors and be sure to connect the limit and motor wires to motor # associated connectors.

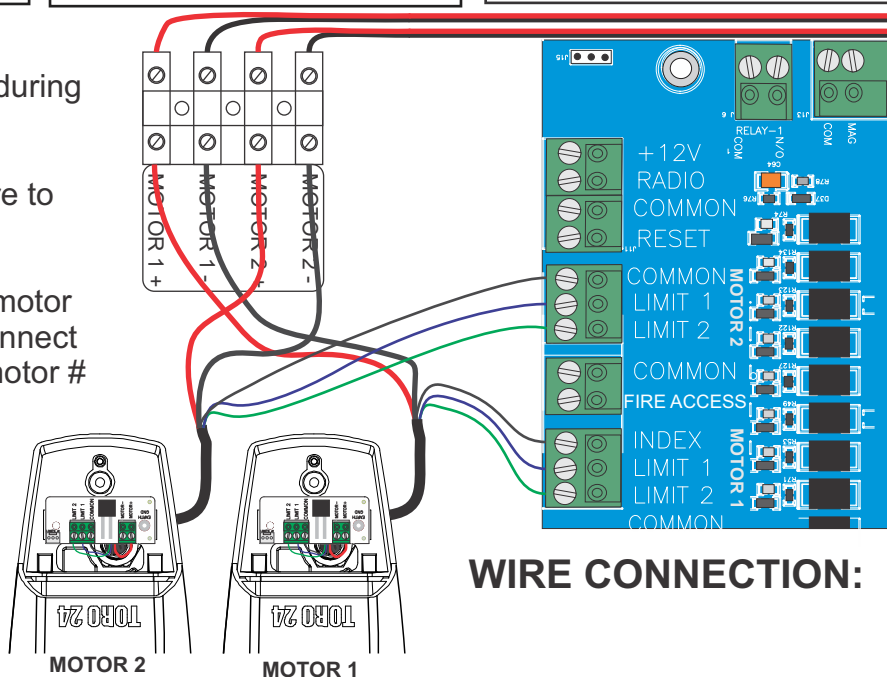

**WIRE CONNECTION:**

# EMERGENCY RELEASE

In case of failure, insert the key and turn counter clockwise to unlock, then turn release handle counter clockwise to release. To latch back to normal operation, simply reverse the procedures.

**Step1. Insert the key and turn Counter Clockwise to unlock**

**Step2. Turn the Release Handle Counter Clockwise to release**

To restore the automation, simply reverse the above procedure.

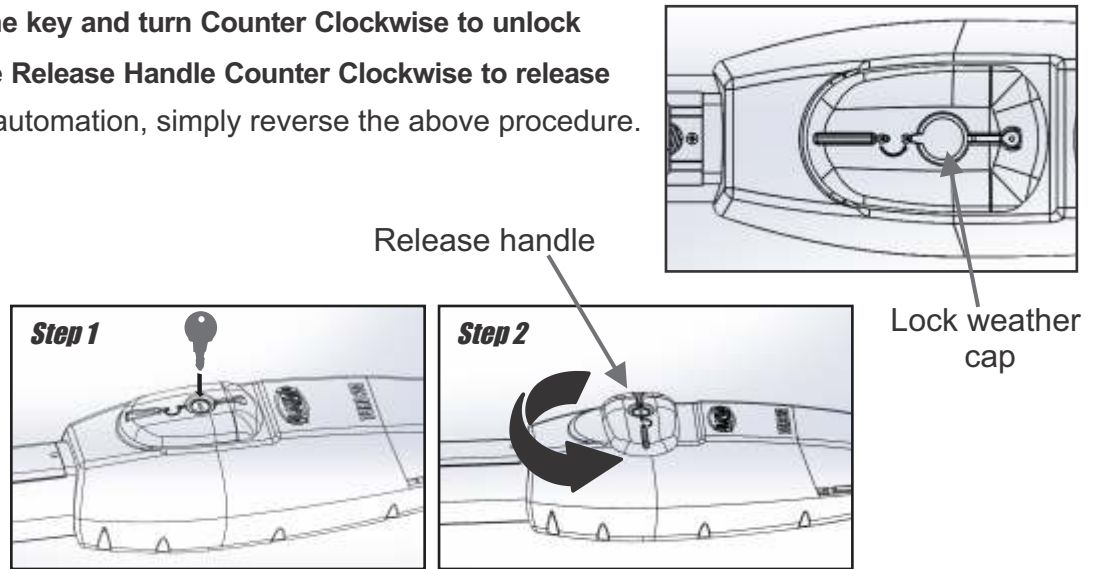

# LIMIT SWITCH ADJUSTMENT

## EASY STEPS TO ADJUST LIMIT SWITCHES

1. Remove limit cover.
2. Find the open and close limits on top of the actuator.
3. Loosen the limit switch screws to allow it to slide and make the open and close adjustment.
4. Once the open and close limits have been set, tighten the screws with a phillips screw driver to lock limits in place.

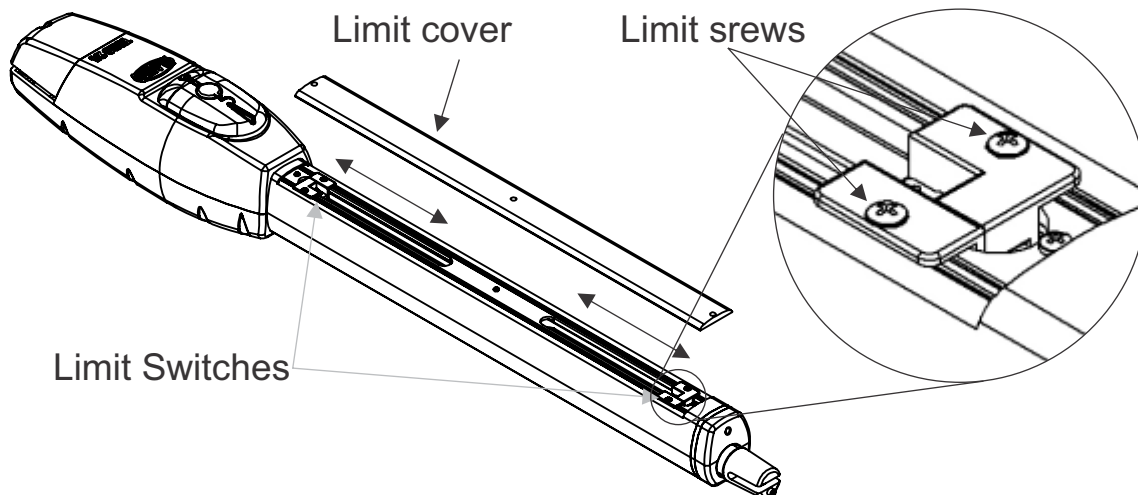

# MACH-PRIME INSTALLATION

## DIMENSIONS

### EXTERIOR PLASTIC COVER

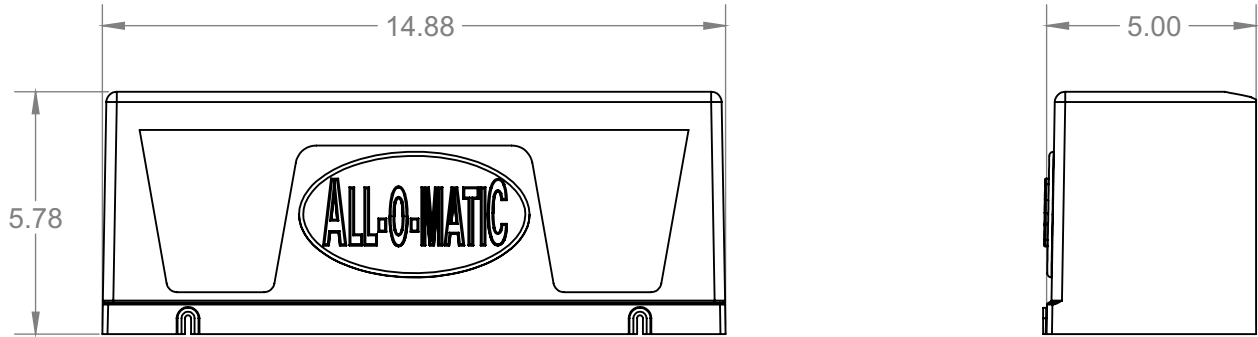

### MOUNTING PLATE

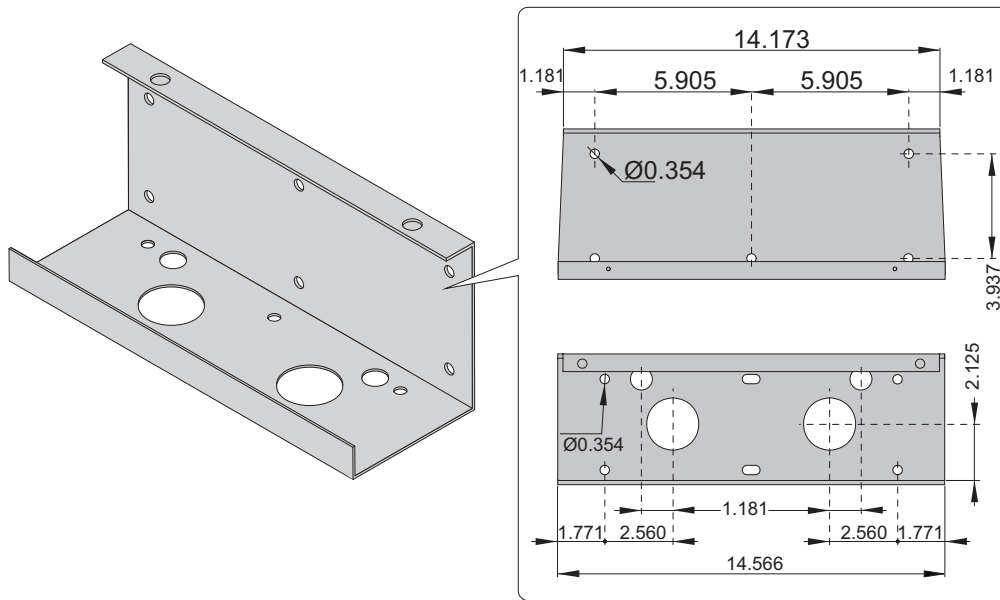

### GATE BRACKET

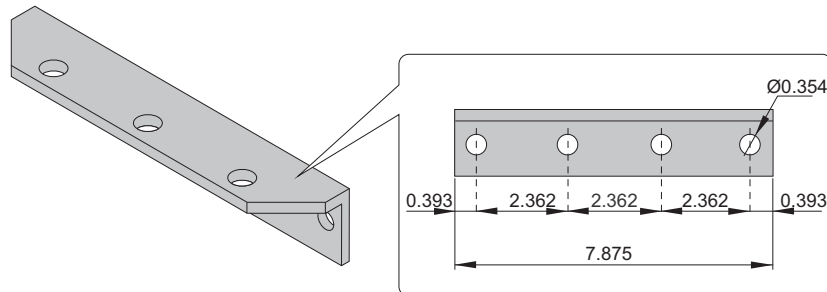

# MACH-PRIME STANDARD INSTALLATION

## Preliminary checks

1. Check that the structure of the column is sufficiently strong to hold the operator.
2. Check the gate hinge and be sure that is properly lubricated and that the gate swings freely open and close.
3. Provide an opening and closing positive stop.



## Operator installation

1. Disassemble the gearhead motor from the mounting plate.
2. Attach the Mounting plate to the gate pillar/column and gate bracket to the gate leaf, according to the type of installation (right or left), as shown in figures below.

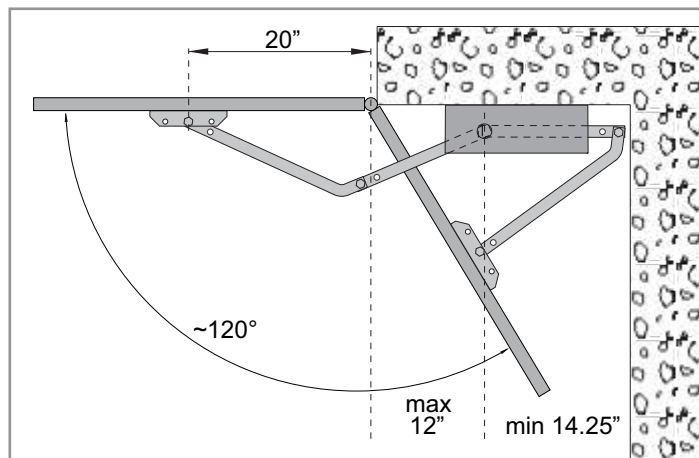
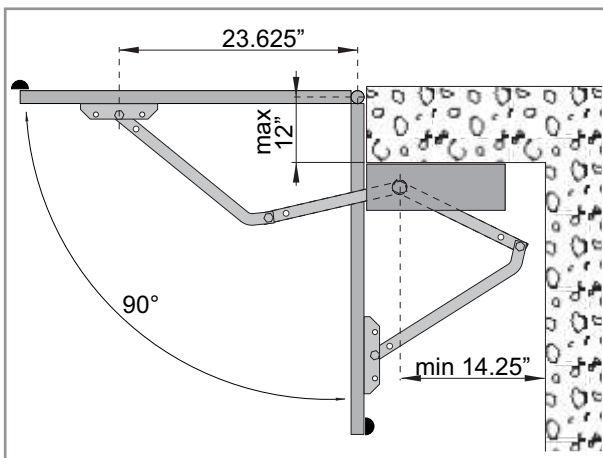

**For columns larger than 24" X 24" call ALL-O-MATIC INC.**

- Assemble the gearhead motor on the mounting plate.

**PAY ATTENTION TO THE TYPE OF INSTALLATION.**

MOUNTING ONTO THE LEFT COLUMN,  
INSIDE VIEW

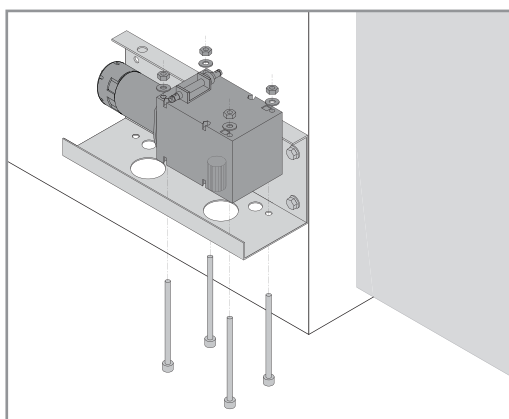

MOUNTING ONTO THE RIGHT COLUMN,  
INSIDE VIEW

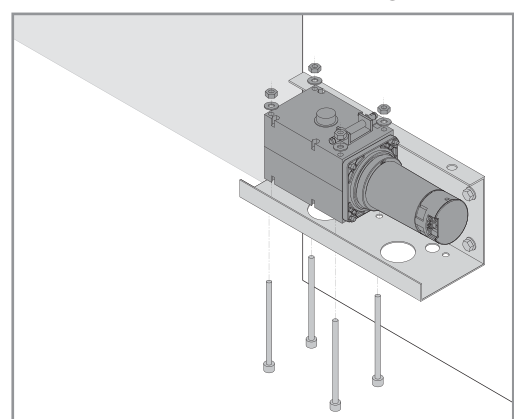



# MACH-PRIME ARM ATTACHMENT

1. Attach the articulating arms, as shown below.

Attention: position the gate in the closed position stop line, align the arms to the proper desired gate bracket hole (A).

2. The arms joints should be lubricated and the bolts tightened in a way that allow arms movement.

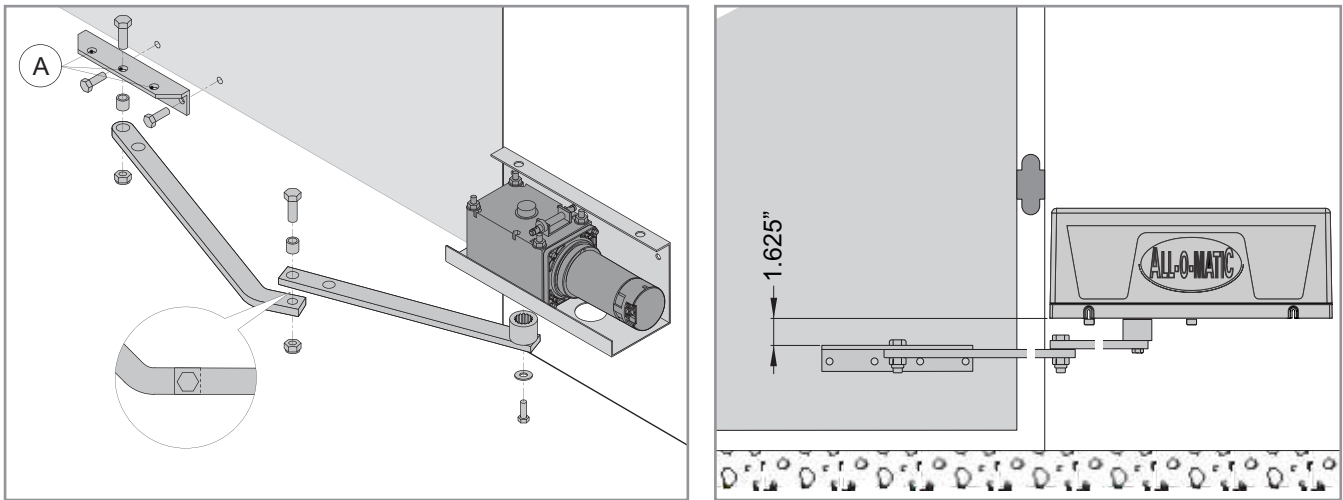

1. To provide manual release access, drill the cover 0.625" hole near release shaft (B). There are two drilling marks inside the cover (for right and left opening) ©.

2. **To release** and manually operate the gate, insert the release key through the hole (D). Once release key is inserted, turn it counterclockwise for gate left gate leaf and clockwise for the right gate leaf. Once released, gate can be operated manually.

**IMPORTANT:** Gate mechanical release must be performed with the power off to the controller.

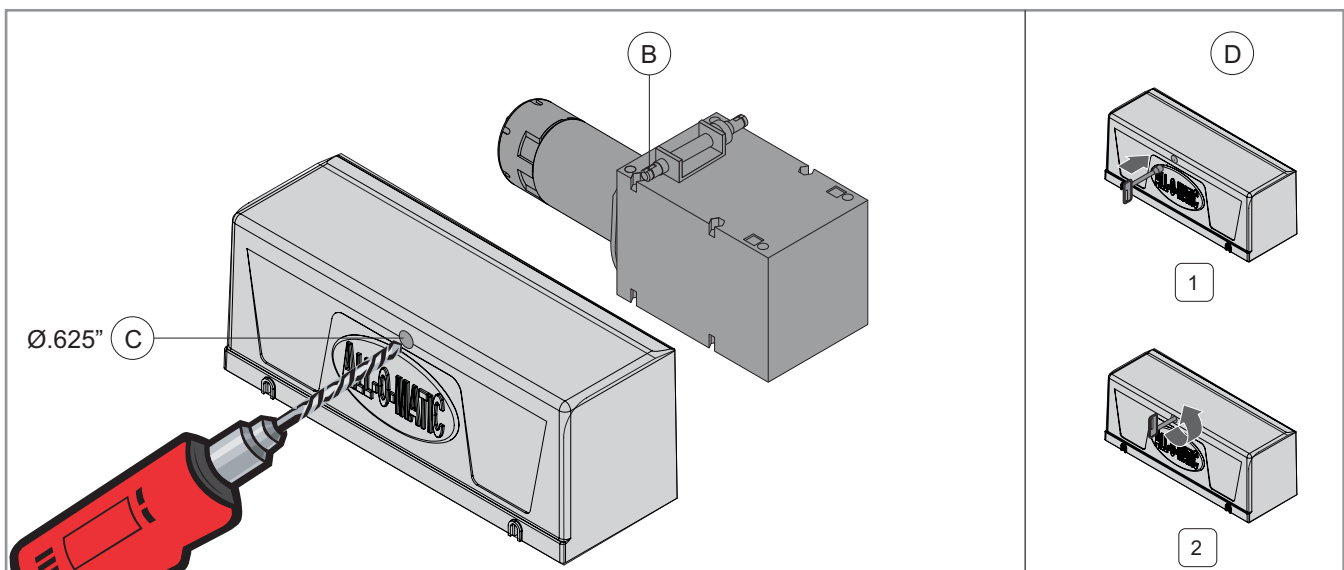

# MACH-PRIME MOTOR WIRING

## Operator cable connections

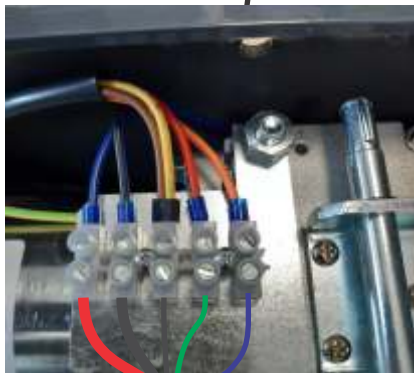

### Left side

Cable to Board	Motor
blue	orange
green	red
black	yel/brwn
black	black
red	blue

### Right side

Motor	Cable to Board
blue	black
black	red
yel/brwn	black
red	blue
orange	green

**IMPORTANT:** The wiring will depend on the side the operator is mounted. Be sure to follow this diagram for the operator to properly operate the gate.

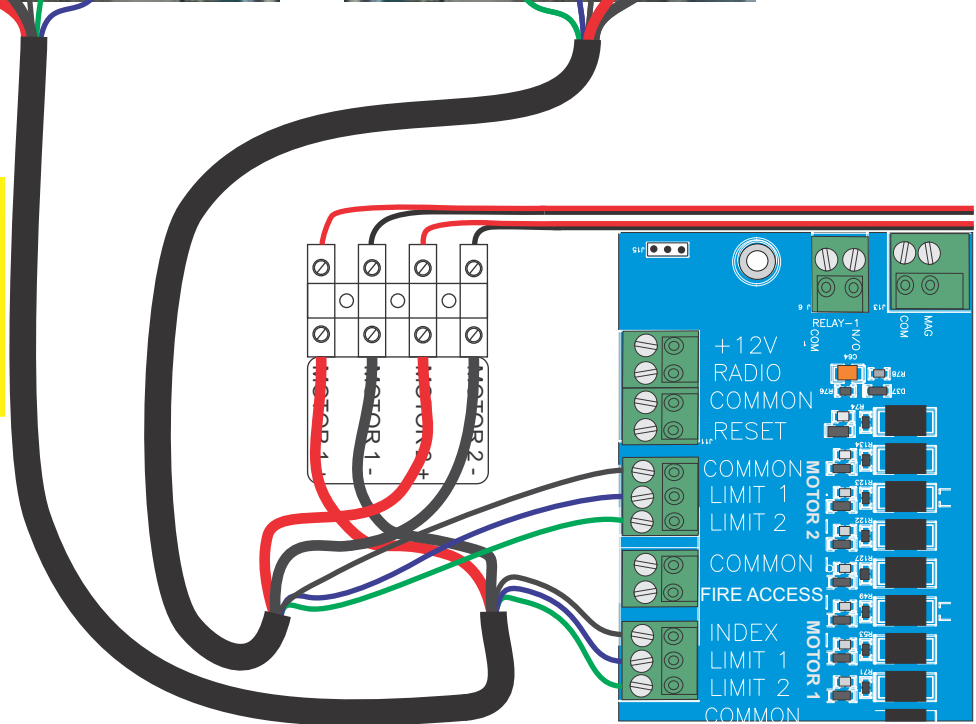

## WIRE CONNECTION:

# MACH-PRIME TRAVEL ADJUSTMENT

Locate the limit switches and identifying which one is open and close, follow the steps below to adjust the gate travel:

1. Use mechanical release to put the unit in manual mode to adjust the limit switches.
2. Move the gate to closed position. Use a screw driver to loosen the limit cam screw(A). turn the limit cam in the desired direction and set close limit switch. Use a screw driver and loosen the fine tune slide screw (B) if necessary. Tighten the screws to secure the limit cam and limit fine tune slide.
3. Move the gate to open position. Use a screw driver to loosen the limit cam screw(A). turn the limit cam in the desired direction and set close limit switch. Use a screw driver and loosen the fine tune slide screw (B) if necessary. Tighten the screws to secure the limit cam and limit fine tune slide.
4. **Set the gate mid travel**, run the gate operator and test limits. Be sure to use the three button station on board to stop the gate before bumping/hitting any structure and protect the equipment and gate.
5. Repeat the steps if more adjustment is needed.
6. When limits are set, move the gate to the closed position. Press and release "RESET" on the circuit board and run the gate one uninterrupted cycle (full open and full close) to learn travel distance and set the slow down.

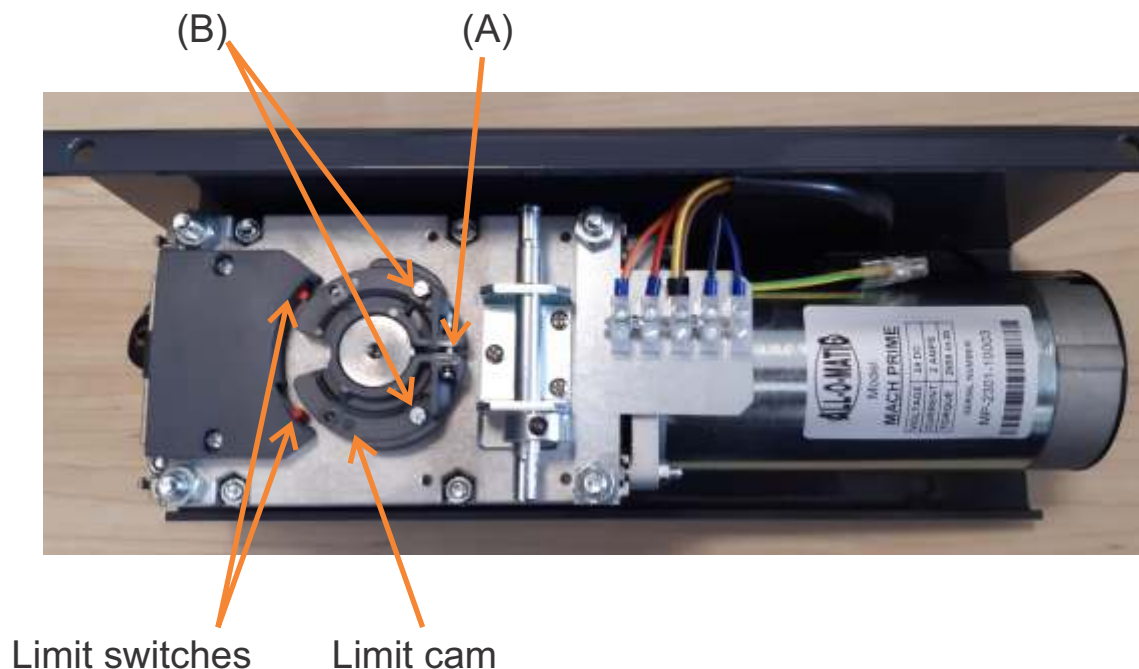

# SETTINGS MENU

## ADVANCED FEATURES

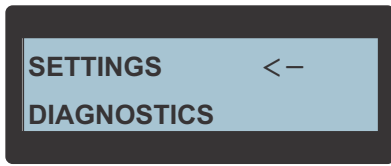

### ENTERING THE SETTINGS MENU

Press the **ENTER** button twice to wake up the LCD display. Press the **<** (left) button to select **ENGLISH**. Select **SETTINGS**, then press **ENTER** (the left **<**- arrow indicates selection). Use the **UP/DOWN** buttons to scroll through the menu list. Make selection, then press **ENTER**. The **<** left button could be use to go back to previous screen.

#### Setting **TIME** and **DATE**:

From the **SETTINGS** menu select the **TIME & DATE**, then press **ENTER**.

- Move cursor to **TIME**, then press **ENTER** to edit time. The time editor will then open. Use the **< RIGHT/LEFT >** buttons to move from hours to minutes and **AM/PM** and **UP/DOWN** buttons to change the time. Press **ENTER** button to save **TIME**.
- Move cursor down to **DATE**, then press **ENTER** to edit **date**. Use the **< RIGHT/LEFT >** buttons to position cursor and **UP/DOWN** buttons to change the date. Press **ENTER** to save the **DATE**.

#### Setting Motor **SPEED**

From the **SETTINGS** menu select **SPEED**, then press **ENTER**. In this sub-menu there are three settings that can be adjusted. Using **UP/DOWN** buttons move the cursor to selection and press **ENTER** to edit each of them.

- **MAX SPEED**: This can be adjusted from **50-100%**. This is the maximum operational speed of the gate. Use the **UP/DOWN** buttons to change the % value and press **ENTER** to save.
- **ACCELERATION**: This can be adjusted from **SLW** (slow), **MED** (medium) and **FST** (fast). This is how fast the gate will ramp up (accelerate) at motor start. Use the **UP/DOWN** buttons to change the setting and press **ENTER** to save.
- **SLOW/DOWN**: This can be adjusted from **70-95%**. This is the percentage of travel where the gate will start slowing down as the gate approaches the open or close limits. Use **UP/DOWN** buttons to change the % value and press **ENTER** to save.

#### Setting Motor **POWER**

From the **SETTINGS** menu select **POWER**, then press **ENTER**. In this sub-menu there are two settings that can be adjusted. Using **UP/DOWN** buttons move cursor to selection, then press **ENTER** to edit each of them.

- **TORQUE**: This can be adjusted for **LOW**, **MED** and **HIGH**. Use **UP/DOWN** buttons to change the setting and press **ENTER** to save.
- **CURR. SENSE**: This sets the way current sense is read. **THLD** (threshold) for normal operation(default). **PRGV** (progressive) for windy areas. Use **UP/DOWN** buttons to change from **THLD** and **PRGV**, then press **ENTER** to save.

#### Setting the **7 DAY TIMER**:

From the **SETTINGS** menu select the **7/DAY TIMER**, then press **ENTER**.

- In the event list, select the **EVENT #** that you would like to program, then press **ENTER** button.
- Select the **ACT.** (action) by scrolling down through the different actions then press **ENTER** when desire action is displayed.
- Set the time for action activation. Using the **UP/DOWN** buttons to change the time and **RIGHT/LEFT** buttons to move from hours, minutes and **AM/PM**. Press **ENTER** button to save the action

time.

- Next, set the time to deactivate the action, using the **UP/DOWN** buttons to change the time and **RIGHT/LEFT** buttons to move from hours, minutes and **AM/PM**. Press **ENTER** button to save the action time.
- Last, set the days of the week that you would like the action to be in effect. Use the **UP/DOWN** buttons to scroll through the days and the **RIGHT** button to toggle the day **ON/OFF**.

Repeat process for each event (1-10 events available).

Action list:

- **OFF (DISABLED)** Nothing happens.
- **OPEN** (opens the gate once)
- **OPEN & HOLD** (opens the gate and holds it open. Only a close event or a close override command will close the gate.)
- **CLOSE** (closes the gate once)
- **CLOSE & HOLD** (closes the gate and holds it closed. Only an open event or an open override command will open the gate.)
- **AUX RELAY ON** (turns the auxiliary relay ON)
- **AUX RELAY OFF** (turns the auxiliary relay OFF)

#### Setting **LEAF DELAY**:

From the **SETTINGS** menu select the **LEAF DELAY**, then press **ENTER**.

- To select which leaf needs the delay press **ENTER** while the cursor blinks on the left side of **DELAY LEAF**. Cursor will then move to make selection, use **UP** button to toggle between **ONE/TWO** leaves, then press **ENTER** to save.
- Then, select **DELAY** and press **ENTER** to edit the delay. Cursor will then move to edit delay, use **UP/DOWN** buttons to set the delay (0.0 to 12.0 Sec). **NOTE**: This is only used on double gate.

**NOTE**: Leaf delay is for the open cycle of selected leaf. The close delay will be for the opposite of selected leaf.

#### Setting **AUXILIARY RELAY**:

From the **SETTINGS** menu select the **AUXILIARY RELAY**, then press **ENTER**. The Cursor is used to show selection.

- Using **UP/DOWN** buttons, select the function, then press **ENTER**.
- If **PRE-WARN SIGNAL** was not selected skip next step.
- If **PRE-WARN SIGNAL** was selected, the delay must be set. Use the **UP/DOWN** buttons to set the pre-warn delay, then press **ENTER** to save.

Functions that can be program to the Auxiliary relay:

**PRE-WARN SIGNAL**: This is used to turn on a strobe light or a siren with a delay before the gate starts to move)

**MOVING SIGNAL**: This will activate the relay and keep it active as the gate is in motion.

**ALARM ALERT**: This will activate the relay when the gate has been tempered with. Use as an alarm sensor output.

**OPENED SIGNAL**: This will keep the relay active while the gate is in the fully opened position.

**CLOSED SIGNAL**: This will keep the relay active while the gate is in the fully closed position.

**NOTE**: an asterisk will appear on selected function.

#### Setting **SERVICE CYCLE**:

From the **SETTINGS** menu select the **SERVICE CYCLE**, then press **ENTER**.

An on board cycle counter is integrated and can be used to program a service call. It can be set at a predetermine # of cycles.

- To set the number of cycles press **ENTER** button. The cursor will then move to the 0 on the ones position.
- Use the **RIGHT/LEFT** buttons to move cursor to other positions and the **UP/DOWN** buttons to increase/decrease values. Press **ENTER** button to save.

**NOTE**: If the service cycle is programmed, the board will start to count down every cycle and alert when the remaining cycles reach 0. The alert is the audible alarm that will beep every hour for 1 minute. If no service cycle was programmed, nothing happens.

## SETTINGS MENU

### Setting AUTO CLOSE TIMER:

From the SETTINGS menu select the **AUTO CLOSE TIMER**, then press **ENTER**.

- Use the **UP/DOWN** buttons to select the number of seconds to set delay. Press enter to save the delay value.
- NOTE: If timer dip-switch is not turned on, a message will be displayed "**SET TIME DIP SWITCH TO ON**".
- This menu item can also be access directly by pressing the **TIMER** push button to quickly go into the setting. Older boards will not have this option.

### Firmware update:

From SETTINGS menu select FIRMWARE UPDATE. If board is equipped with an USB A plug, it has the ability to update the firmware in the field. Call ALL-O-MATIC for instructions on this.

### Setting to DEFAULT:

From the SETTINGS menu select the **SET TO DEFAULT**, then press **ENTER**.

In this section the user is allowed to set the programming back to factory settings (factory default).

Use the **UP/DOWN** buttons to select the parameter that you would like to set back to factory default and press **ENTER**.

**DEFAULT ALL** will set every parameter back to factory settings.

This very useful when you are not sure what has been programmed.

## DIAGNOSTICS MENU

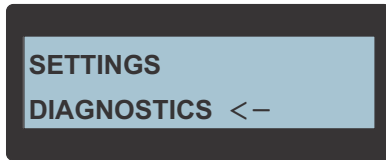

### ENTERING THE DIAGNOSTICS MENU

Press the **ENTER** button twice to wake up the display.

Press the **< left button** to select **ENGLISH**.

Using the **UP/DOWN** buttons select **DIAGNOSTICS**, then press **ENTER**. The **< left button** could be used to go back to previous screen.

Using the **UP/DOWN** buttons move to selection, then press **ENTER**.

- **GATE STATUS:** This displays the status of the gate (OPENING, CLOSING, OPENED, CLOSED, STOPPED or STOPPED ERD)
- **METER:** The meter will display Battery Voltage and LINE IN Voltage. Use the **UP/DOWN** buttons to scroll thru the different items.
- **MOTOR ONE and MOTOR TWO:** This will display the motor one & two speed and position of the gate travel. Use the **UP/DOWN** to scroll to **SPEED** and **TRAVEL**.
- **LAST EVENT:** This will display the last event recorded.
- **EVENT LOG:** This is a very useful event log that displays up to 50 abnormal events with date and time stamp that are recorded as they happen. Use the **UP/DOWN** buttons to scroll thru the events list.
- **CYCLE COUNT:** This will display the following cycle counts;

#### LIFE CYCLES

#### MONTH CYCLES

#### DAY CYCLES

**SERVICE COUNT:** This will show the **REMAINING CYCLES**.

This will only show if a service was programmed. An indication to reset will show when remaining cycles reach 0

- **EXPORT TO USB:** This will allow the user to export the diagnostics data to a flash drive. Call for instructions.

## MENU DESCRIPTION

**<ENG:** English selection by pressing **<** left button.

**ESP.>:** Spanish selection by pressing **>** right button.

**1. SETTINGS:** Settings menu selection by pressing enter while settings is selected.

**1.1 TIME & DATE:** This menu is to edit/adjust time and date.

**1.2 SPEED:**

**1.2.1 MAX SPEED:** This is the maximum speed for the motor

**1.2.2 ACCELERATION:** This is the acceleration rate (range: slow, medium and fast).

**1.2.3 SLOW/DOWN:** This the percentage of travel where the motor will start slowing down as it approaches the limits.

**1.3 POWER:**

**1.3.1 TORQUE:** There are three levels of torque (Low, Med and high).

**1.3.2 CURR. SENSE:** Current sense is to select the way the board reads current from the load. Threshold (**THLD**) is default and is recommended for normal operation.

Progressive (**PRGV**) is for gates installed where wind is a factor.

**1.4 7/DAY TIMER**

**1.4.1 EVENT 1:** There are 10 programmable events.

**1.4.2 EVENT ACT.:** This is where the actions is selected.

**1.4.3 TIME:** Time when the action takes place.

**1.4.4 TIME:** time when the action is deactivated.

**1.4.5 DAYS (ACTIVE):** Days that require the the action to be active. Each day needs to be turn on manually using the **>** right button to toggle ON/OFF.

**1.5 LEAF DELAY**

**1.5.1 DELAY LEAF:** This is for the leaf selection.

**1.5.2 DELAY:** To set the delay of selected leaf.

**1.6 AUXILIARY RELAY**

**1.6.1 RELAY ACTION:** Selection of the action for the relay function.

These are the available actions.

**1.6.1.1 OFF (INACTIVE)**

**1.6.1.2 PRE-WARN SIGNAL**

**1.6.1.2.1 DELAY**

**1.6.1.3 MOVING SIGNAL**

On when gate is in motion.

**1.6.1.4 ALARM SIGNAL**

On when tempered with operator.

**1.6.1.5 OPENED SIGNAL**

On when gate fully open.

**1.6.1.6 CLOSED SIGNAL**

On when gate fully closed.

**1.7 SERVICE CYCLE**

**1.7.1 SERVICE CYCLE COUNT:** This is used to program a service call. You set the number of cycles you want the gate to run before the customer gives you a call. The audible alarm will notify the end user with double beep when it's time for the service call.

**1.8 AUTO CLOSE TIME,** This is to set the timer delay to close gate.

**1.9 UPDATE FIRMWARE,** This is to update firmware in the field. Call ALL-O-MATIC for more information.

**1.10 SET TO DEFAULT**

**1.10.1 DEFAULT ALL:** This selection will set all parameters to factory settings.

**1.10.2 DEFAULT SPEED**

**1.10.3 DEFAULT POWER**

**1.10.4 DEFAULT 7/D TMR**

**1.10.5 DEFAULT LEAF DLY**

**1.10.6 DEFAULT RLY FUNC**

**1.10.7 DEFAULT SVC C**

**1.10.8 DEFAULT SW CONF.**

# ELECTRICAL CONNECTION

**OPERATORS MUST BE PROPERLY GROUNDED!**

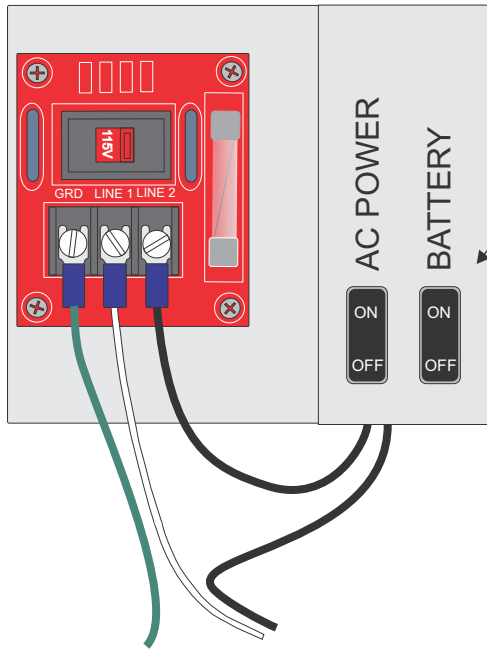

Power & Battery Switches

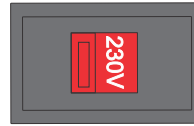

**NOTE:** When applying 230V to operator make sure voltage switch is flipped to 230V position.

Power connection	115VAC	220VAC Single Phase
LINE 1 =	115V HOT	220V LINE 1
LINE 2 =	115V N	220V LINE 2

**GND** Connect to ground. Use a proper **ground rod** for a ground reference.

Use the shortest and thickest wire possible for ground.

For power, a minimum of a **20-Amp** dedicated circuit breaker is needed.

**For power wire enclosure use UL listed conduits.**

All gate operators **MUST** be properly grounded.

A proper ground in a gate operator installation minimizes or prevents damage from an electrical charge, such as a near lightning strike or an electrical static discharge.

Use a single wire for the ground. **DO NOT** splice two wires for the ground. If the wire breaks or is cut, replace it with a single length. **NEVER** use two wires for the ground.

Check with your City code for proper earth ground rod type and proper grounding procedures.

# SWINGER LOOP LAYOUT

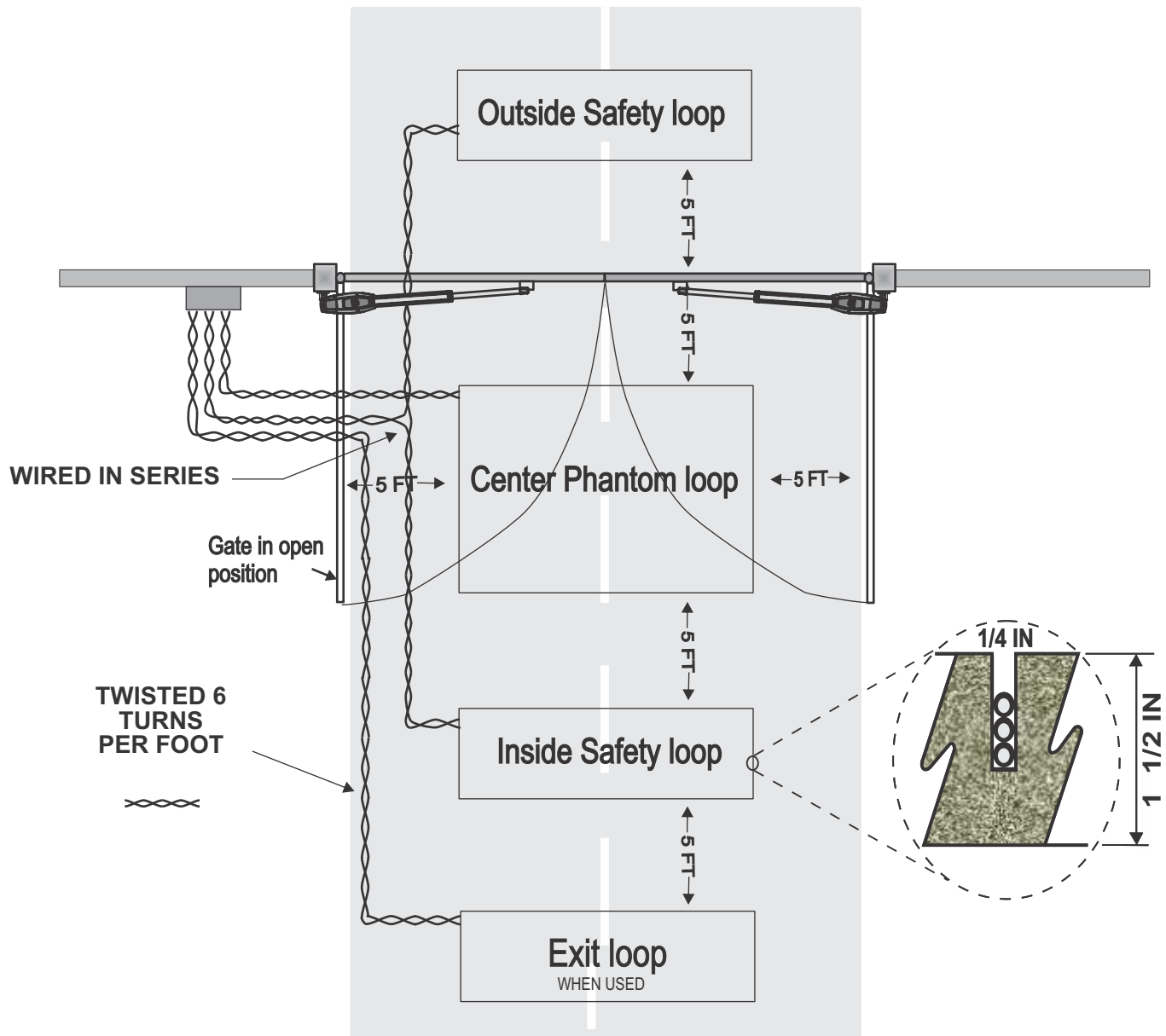

This is a normal loop layout. Remember when connecting to an All-O-Matic circuit board you use the normally closed contacts (N.C.) from the safety loop detector and normally open contacts from the exit and phantom loop detectors. You must twist the loop wires from the exit point of the saw cut of each loop all the way to the loop rack, no exceptions.

The TORO 24 control box includes the plug-in loop rack for EXIT, PHANTOM and SAFETY (reverse) loop detectors.

# GENERAL LOOP INSTALLATION GUIDELINES

The following loop installation guidelines are for installing typical driveway loops for access control applications (i.e. parking gates, sliding gates, swing gates etc...) Always consult with loop detector manufacturers for specific equipment guidelines. This will confirm that the proper configuration and installation techniques are applied for your application.

Useful information about inductive loops:

- A. The typical sensing height is 2/3 of the shortest leg of loop (in feet)  
Therefore a 4' x 8' loop typically has a detection height of 2.6'.
- B. The inductance of a conventional four-side loop can be estimated using the formula:

$$L = P \times (T^2 + T) / 4$$

Where L = Loop Inductance in microHenries

P = Loop Perimeter in feet

T = Number of turns of wire in saw slot

Therefore a 4' x 8' loop with 3 turns would be:

$$L = (4 + 8 + 4 + 8) \times (3^2 + 3) / 4$$

$$L = 24 \times (9 + 3) / 4$$

$$L = 24 \times 12 / 4$$

$$L = 24 \times 3$$

$$L = 72 \text{ microHenries}$$

Suggested guidelines for loop installation:

Loop wires should be twisted 6 turns per foot, and twisted from saw slot to the detector. If possible start twisting the wires from the edge of the loop.

All 90 degree corners should be chamfered so that the course of the wire does not change direction sharply but rather at shallower angles of 45 degrees or less. Core drilling of the corners achieves the same effect but can still lead to failure due to sharp edges remaining in the corner area.

Loop Perimeter	# of Turns
6' - 12'	6
13' - 20'	5
21' - 60'	4
61' - 240"	3
241 & Up	2

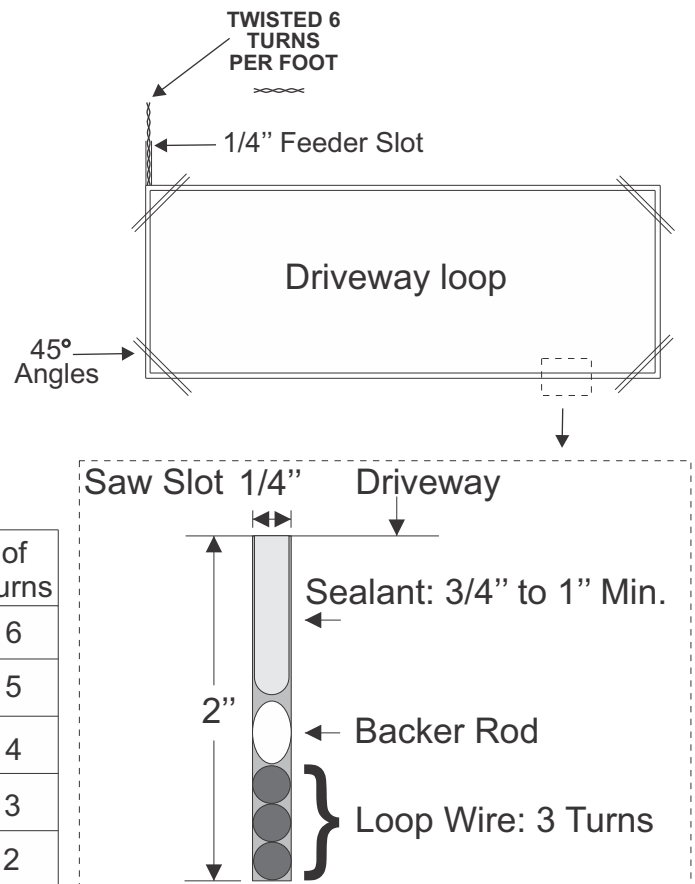



# ENTRAPMENT PROTECTION INSTALLATION FOR SWINGING GATES

A minimum of two monitored entrapment protection devices are **required** for each entrapment zone. All locations or point of contact where a person can become entrapped between a moving gate and a rigid object is considered an entrapment zone. The operator has an inherent entrapment protection (**ERD**) system. It requires an external monitored entrapment protection device (contact edge sensor or non-contact photoelectric sensor) for each entrapment zone prior to gate operation. The operator cycles power to the external entrapment protection device and checks for device signals. If the operator does not receive the correct feedback from the device, the gate will not operate.

Below are some samples of entrapment zones and where the entrapment protection devices should be installed.

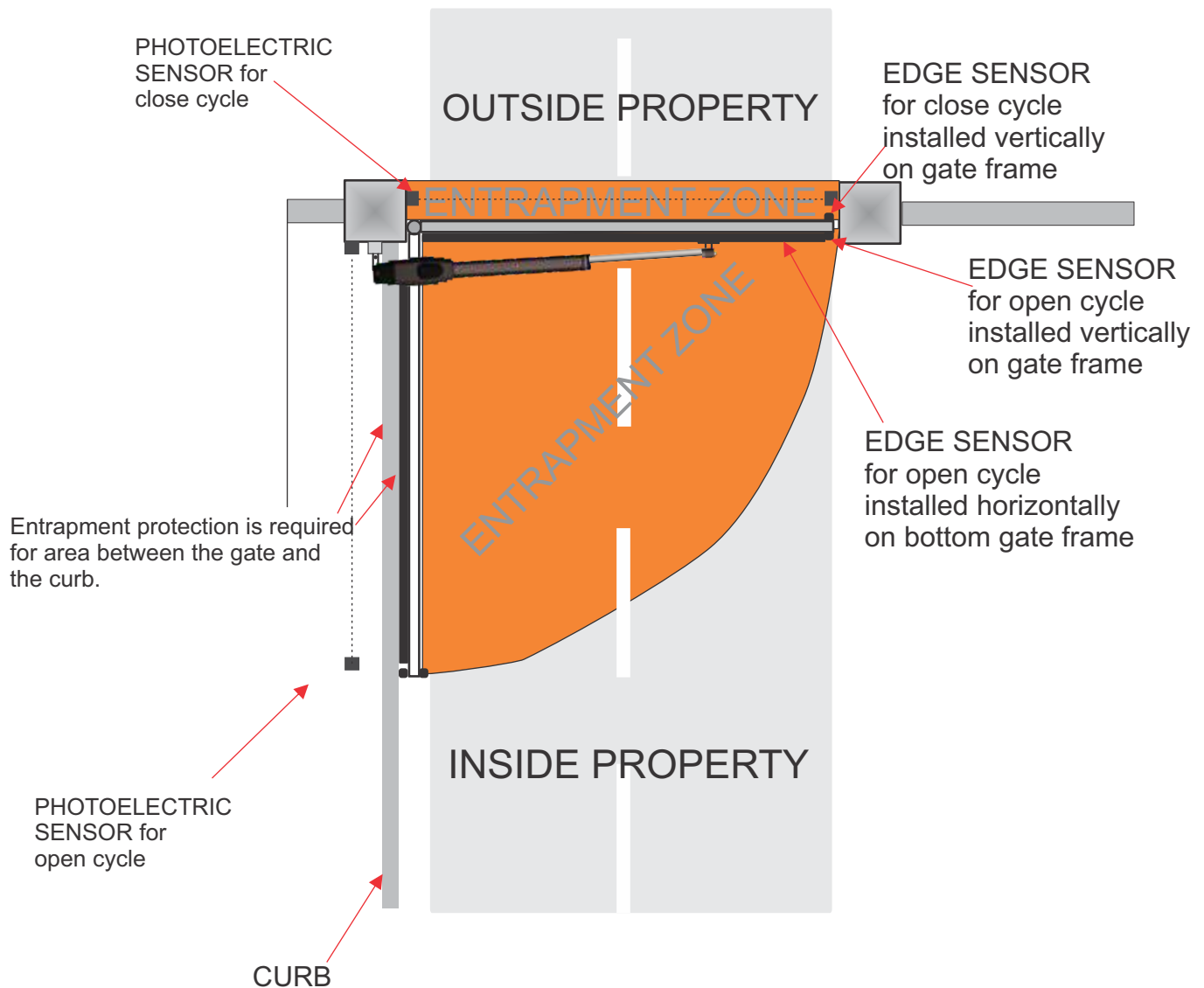

# ENTRAPMENT PROTECTION DEVICE CONNECTIONS

There are two type of entrapment protection devices that can be connected to the operator, NON-CONTACT SENSOR (PHOTO EYE) and CONTACT SENSOR (EDGE SENSORS). These inputs are for monitored ENTRAPMENT PROTECTION devices.

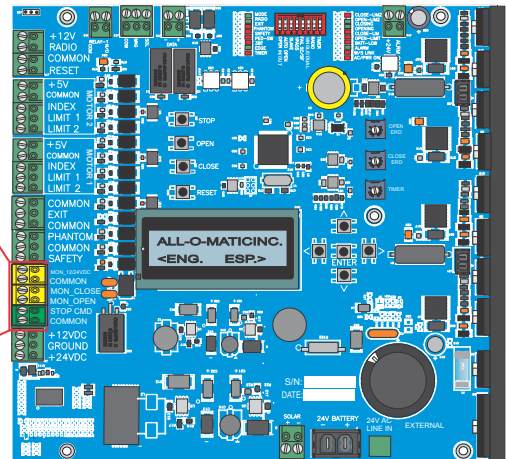
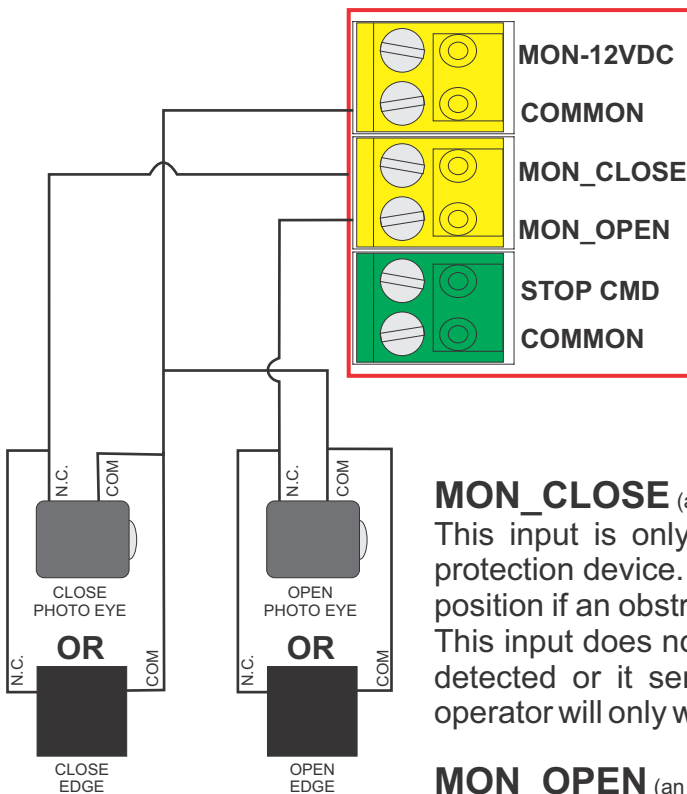

PCB model: T24PCB

**MON\_CLOSE** (an LED will indicate when an obstruction is detected or device not present)  
This input is only for the close direction monitored entrapment protection device. When gate is closing it will open to the full open position if an obstruction is sensed and resets the auto close timer. This input does nothing in the opening direction. If a device is not detected or it senses a fault (**MON\_FAULT** LED will turn ON), the operator will only work on constant pressure actuated switch.

**MON\_OPEN** (an LED will indicate when an obstruction is detected or device not present)  
This input is only for the open direction monitored entrapment protection device. When gate is opening it will reverse 2 seconds and stop if an obstruction is sensed. This input does nothing in the closing direction. On power up, if a device presence is not detected the operator will assume one is not required for opening direction. If a device is connected and board detects a fault (**MON\_FAULT** LED will turn ON), the operator will only work on constant pressure actuated switch.

**Operators now include the AOM-RED EYE sensor. See page 18 for wiring diagram.**

Monitored entrapment protection devices use four wires to connect to the board. From the device, connect **relay common** to board **COMMON** and **N.C.** relay contact to assigned **MON\_OPEN** or **MON\_CLOSE** input. Connect the power wires to the **COMMON** and **MON-12VDC**. **VERY IMPORTANT:** The **MON-12VDC** supply must be used (not the normal 12VDC terminal) to properly monitor entrapment protection devices.

Refer to the device manufacturer wiring instructions for details. Be sure to follow the **N.C.** directions. Some devices may work on different monitoring interfaces as well as the **N.C.**.

Should there be a need for more than one entrapment protection device for each direction, a multi-input module from Miller Edge Model: MIM-62 (not included) may be used .

# ENTRAPMENT PROTECTION DEVICE CONNECTIONS

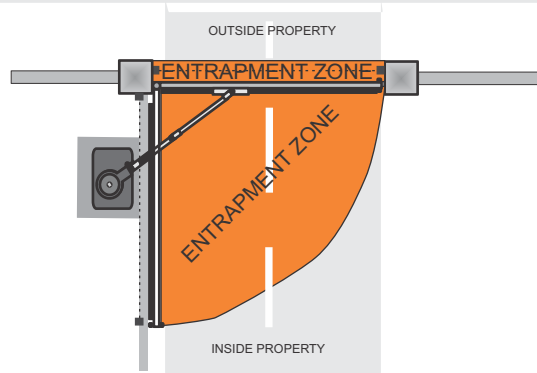

## WIRING DEVICE ACROSS DRIVEWAY / CLOSE DIRECTION (MON\_CLOSE)

WIRING THE AOM-RED-EYE  
(INCLUDED WITH OPERATOR)  
TO THE CIRCUIT BOARD

→

BE SURE TO HAVE THE AOM-RED-EYE  
IN LIGHT ON MODE

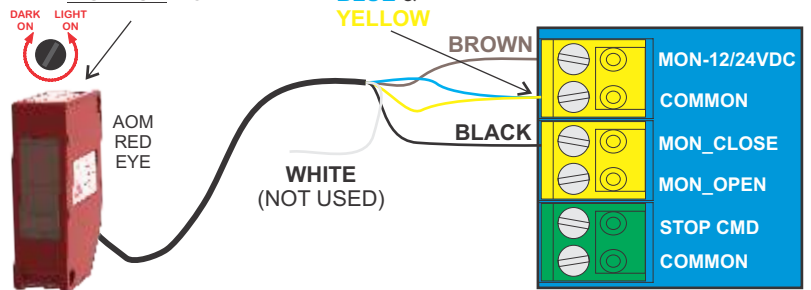

### WIRE TO THE YELLOW CONNECTOR

FOR OMRON E3K,  
USE RELAY C2 AND NO 2

ENFORCER PHOTOCELL  
MODELS MUST END IN -GQ

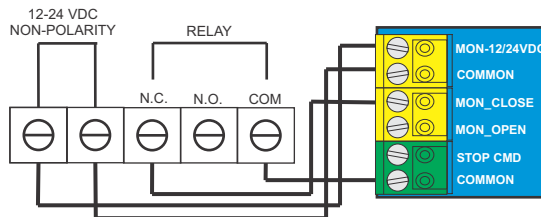

WIRING OTHER  
PHOTOCELLS TO  
THE CIRCUIT BOARD

←

## WIRING DEVICE FOR OPEN DIRECTION (MON\_OPEN)

WIRING THE AOM-RED-EYE  
(INCLUDED WITH OPERATOR)  
TO THE CIRCUIT BOARD

→

BE SURE TO HAVE THE AOM-RED-EYE  
IN LIGHT ON MODE

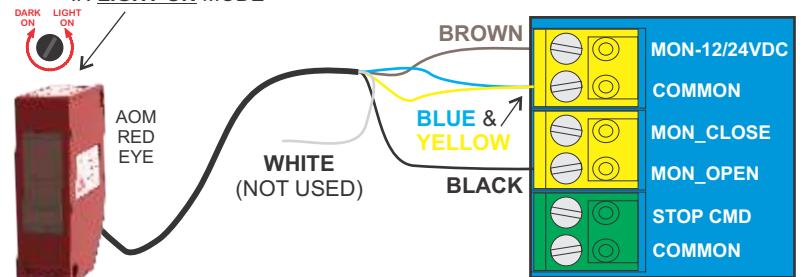

### WIRE TO THE YELLOW CONNECTOR

FOR OMRON E3K,  
USE RELAY C2 AND NO 2

ENFORCER PHOTOCELL  
MODELS MUST END IN -GQ

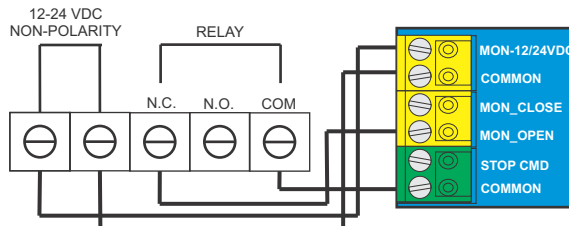

WIRING OTHER  
PHOTOCELLS TO  
THE CIRCUIT BOARD

←

# ENTRAPMENT PROTECTION DEVICE CONNECTIONS

ENFORCER E-960-D90GQ/	
CONTACT	BOARD
N.C.	MON_CLOSE OR
COM	COMMON
12-30 VDC/AC	COMMON
12-30 VDC/AC	MON_12/24VDC

ENFORCER	
WIRE	BOARD
BLACK	MON_CLOSE OR
WHITE	COMMON
BLUE	COMMON
BROWN	MON_12/24VDC

ALLEN BRADLEY	
WIRE	BOARD
BLACK	MON_CLOSE OR
ORANGE	COMMON
BLUE	COMMON
BROWN	MON_12/24VDC

OMRON		
SWITCH	CONTACT	BOARD
LIGHT	N.O.2	MON_CLOSE
	C.2	COMMON
	24 TO 240	COMMON
	24 TO 240	MON_12/24VDC

EMX		
SWITC	CONTACT	BOARD
SW1 -	N.C.	MON_CLOSE OR
SW2 -	COM	COMMON
SW3 -	POWER/	COMMON
SW4 -	POWER/	MON_12/24VDC

EMX	
CONTACT	BOARD
N.C.	MON_CLOSE OR
COM	COMMON
POWER	COMMON
POWER	MON_12/24VDC

EMX	
WIRE	BOARD
BLACK	MON_CLOSE OR
WHITE	COMMON
BLUE	COMMON
BROWN	MON_12/24VDC

EMX		
SWITC	CONTACT	BOARD
SW1 -	N.C.	MON_CLOSE OR
SW2 -	COM	COMMON
SW3 -	POWER/	COMMON
SW4 -	POWER/	MON_12/24VDC

TRANSMITTER SOLUTIONS	
CONTACT	BOARD
N.C. (3)	MON_CLOSE OR
COM (5)	COMMON
NON POLARITY (1)	COMMON
12-30 VDC/AC (2)	MON_12/24VDC

TRANSMITTER SOLUTIONS		
SWITCH	CONTACT	BOARD
ALL	N.C.1	MON_CLOSE
	COM	COMMON
	(-) 12/24	COMMON
	(+) 12/24	MON_12/24VDC

EMX	
CONTACT	BOARD
RELAY CLOSE (NC)	MON_CLOSE
RELAY CLOSE	COMMON
POWER	COMMON
POWER	MON_12/24VDC

MILLER EDGE RBAND 6 WIRES FOR 1 EDGE - 8 WIRES FOR 2 EDGES		
SWITCH	CONTACT	BOARD
SW 1 -	N/C	MON_CLOSE
SW 2 -	COM	COMMON
SW 3 -	COM	COMMON
SW 4 -	12/24 (+)	24-VDC

MON\_CLOSE = PROTECTS ACROSS THE DRIVEWAY/CLOSING DIRECTION  
 MON\_OPEN = PROTECTS THE REAR SLIDE / OPENING DIRECTION

# ACCESSORY CONNECTIONS

The circuit board **12 or 24VDC** output provides up to **500** mAmps each of power for accessories. More than two or three accessories will require a separate power supply.

**NOTE:** **12 or 24VDC** Accessories only.

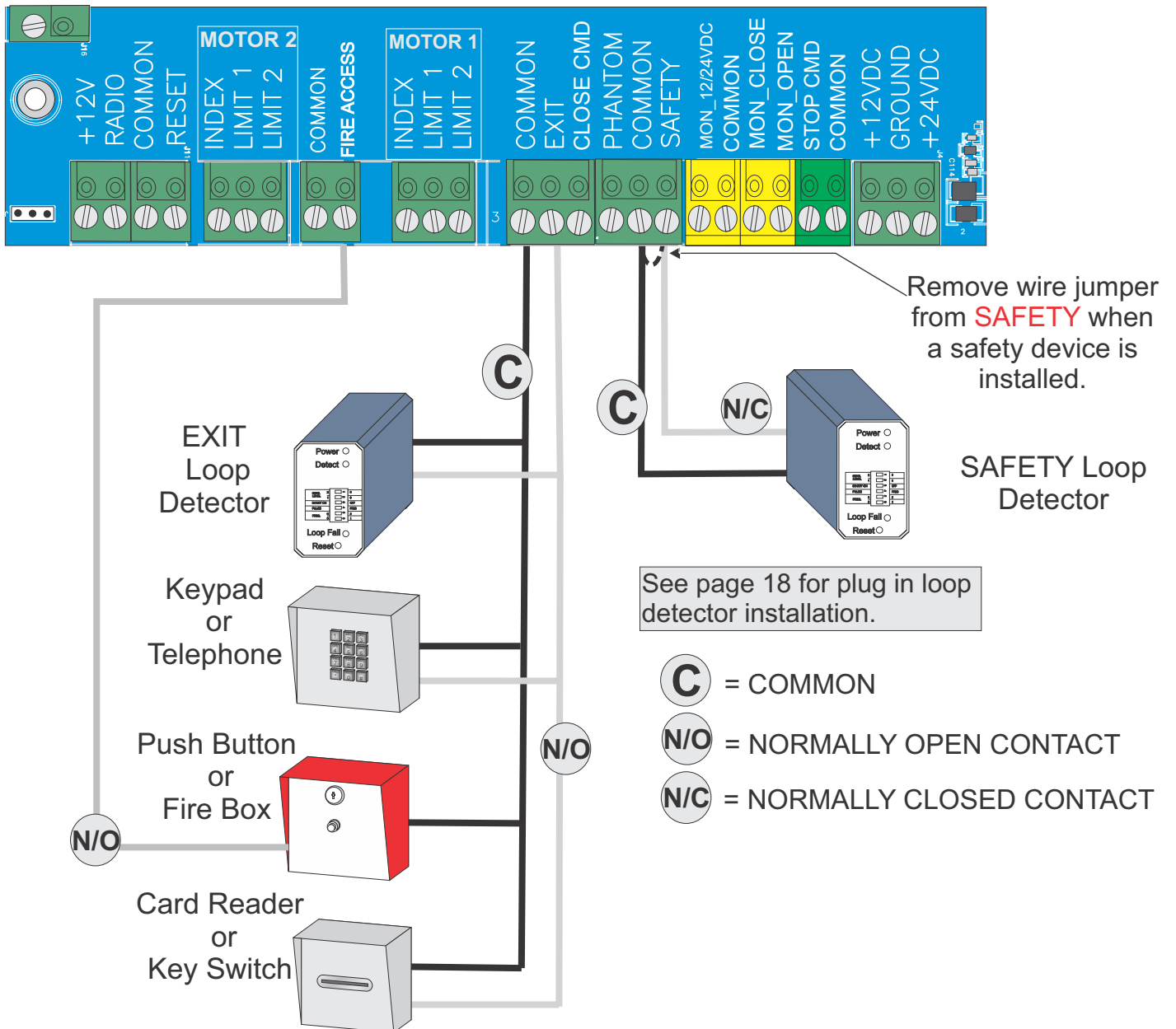

# LPR-2 LOOP RACK INSTALLATION

- The Toro operator comes equipped with the pre-wired LPR-2 loop rack for safety, phantom, and exit plug in loop detectors, making installation quick and efficient.
- Hardwired loop detectors with harnesses can also be installed. The circuit board has 12 VDC and 24 VDC terminals to power the detector of your choice. See “Accessory Connections” page for wiring instructions.
- Wire one or more safety devices in series with the loop rack wires. To do this, remove the white wire (N.C) from the loop rack off of the SAFETY terminal on the circuit board and wire nut to the COM of the additional device. The N.C. contact of the additional device will now go on the SAFETY terminal of the board.
- **IMPORTANT:** Use different frequencies for each loop detector to eliminate interference.

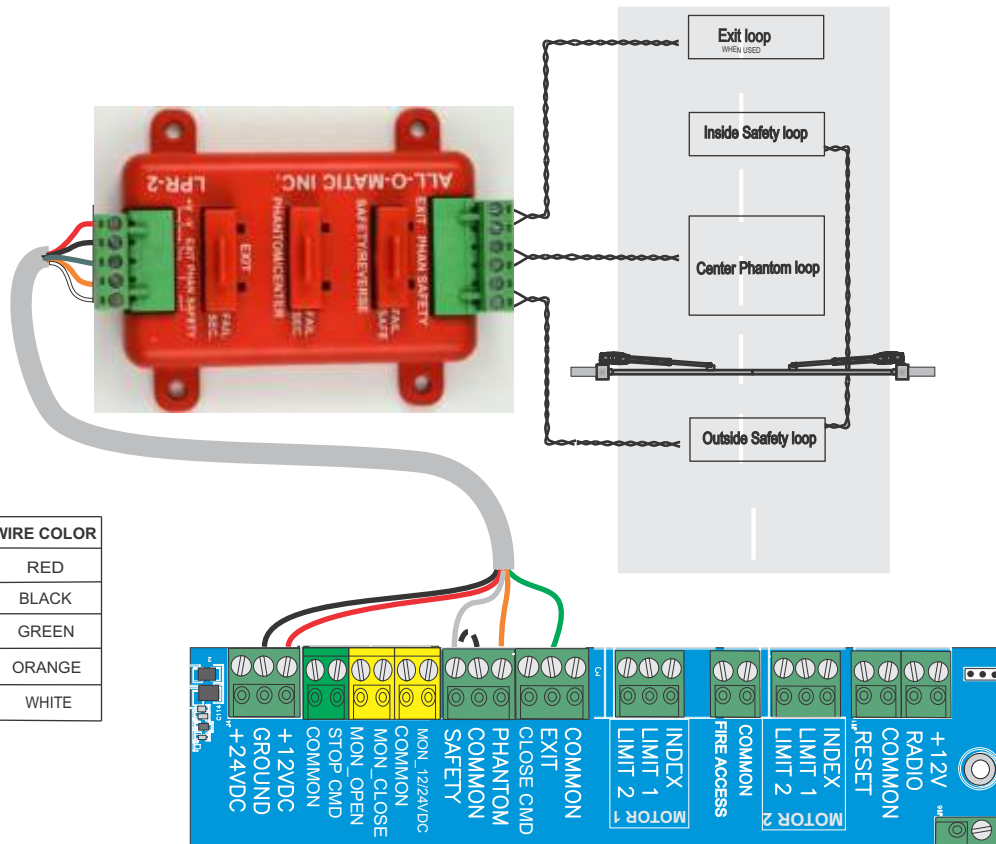

LOOP RACK	DC BOARD	WIRE COLOR
12VdC	12-VDC	RED
GROUND	GROUND	BLACK
EXIT	EXIT	GREEN
PHANTOM	PHANTOM	ORANGE
SAFETY	SAFETY	WHITE



**ALL-O-MATIC**

**PRIME-VD1**  
VEHICLE DETECTOR

**INDICATORS:**  
 RED - DETECT  
 GREEN - PWR/LOOP FAIL

**GREEN LED BLINKING INDICATE LOOP FAIL:**  
 1 BLINK - OPEN LOOP  
 2 BLINKS - LOOP SHORTED

**SETTINGS**

SENSITIVITY	SW1	SW2
LOW	OFF	OFF
MEDIUM LOW	ON	OFF
MEDIUM HI	OFF	ON
HIGH	ON	ON

FREQUENCY	SW5	SW6
HIGH	OFF	OFF
MEDIUM HI	ON	OFF
MEDIUM LOW	OFF	ON
LOW	ON	ON

**OUTPUT**

OUTPUT	SW3
FAIL-SECURE	OFF
FAIL-SAFE	ON

USE FAIL-SAFE FOR SAFETY/  
 REVERSE LOOP. FAIL-SECURE  
 FOR EXIT OR PHANTOM LOOPS.

PRESS RESET AFTER CHANGING  
 SENSITIVITY AND FREQUENCY SETTINGS

OUTPUT	SW3
EXIT/PHANTOM	OFF
SAFETY	ON

# THREE BUTTON STATION SYSTEM

See push button connections below.

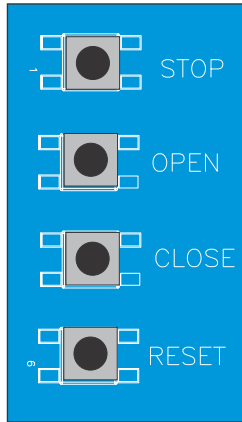

A three button station was integrated on the board to make adjustments easier when setting limit switches and adjusting ERDs.

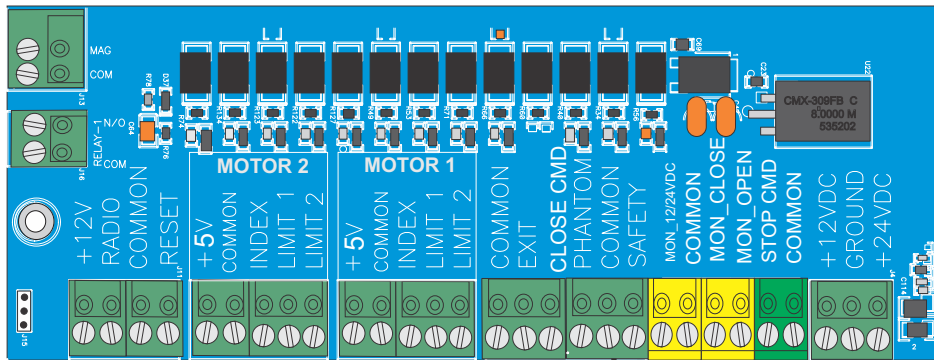

Connect the **COMMON** from all the push buttons to **COMMON** input on the board.

Connect **OPEN** push button **N.O.** contact to **EXIT** input on the board.

Connect **CLOSE** push button **N.O.** contact to **3BT** input on the board.

Connect **STOP** push button **N.C.** Contact to **PED-SW** input on the board and remove **PED-SW** jumper.

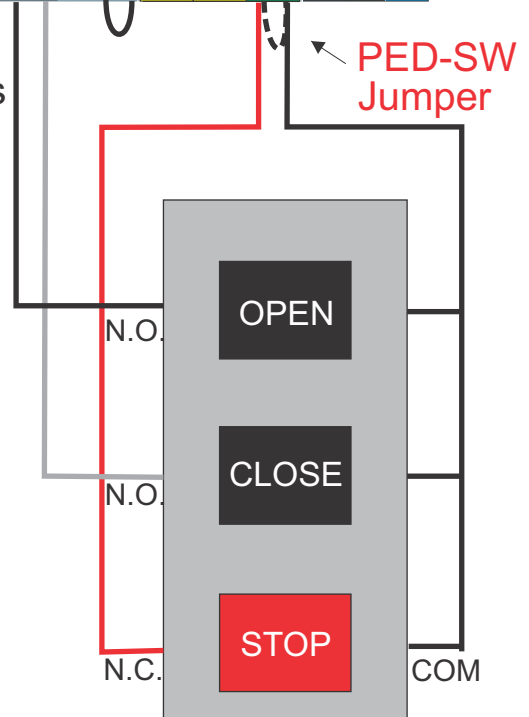

# MAGNETIC/SOLENOID LOCK CONNECTION

Magnetic lock installation requires a step down transformer with appropriate voltage for the specific lock accessory. Operator will provide a 120VAC outlet for the step down transformer.

**Connections:** Plug the lock device transformer to the 120VAC outlet plug.

**For Magnetic lock:** Connect one wire from transformer directly to one wire of the magnetic lock, the other wire from transformer will be connected to the relay plug **COM** input and the **MAG** relay output connects to the other wire of the magnetic lock. See illustration below.

**For Solenoid lock:** Connect one wire from transformer directly to one wire of the solenoid lock, connect the other wire from transformer to the relay plug **COM** input and the **SOL** relay output

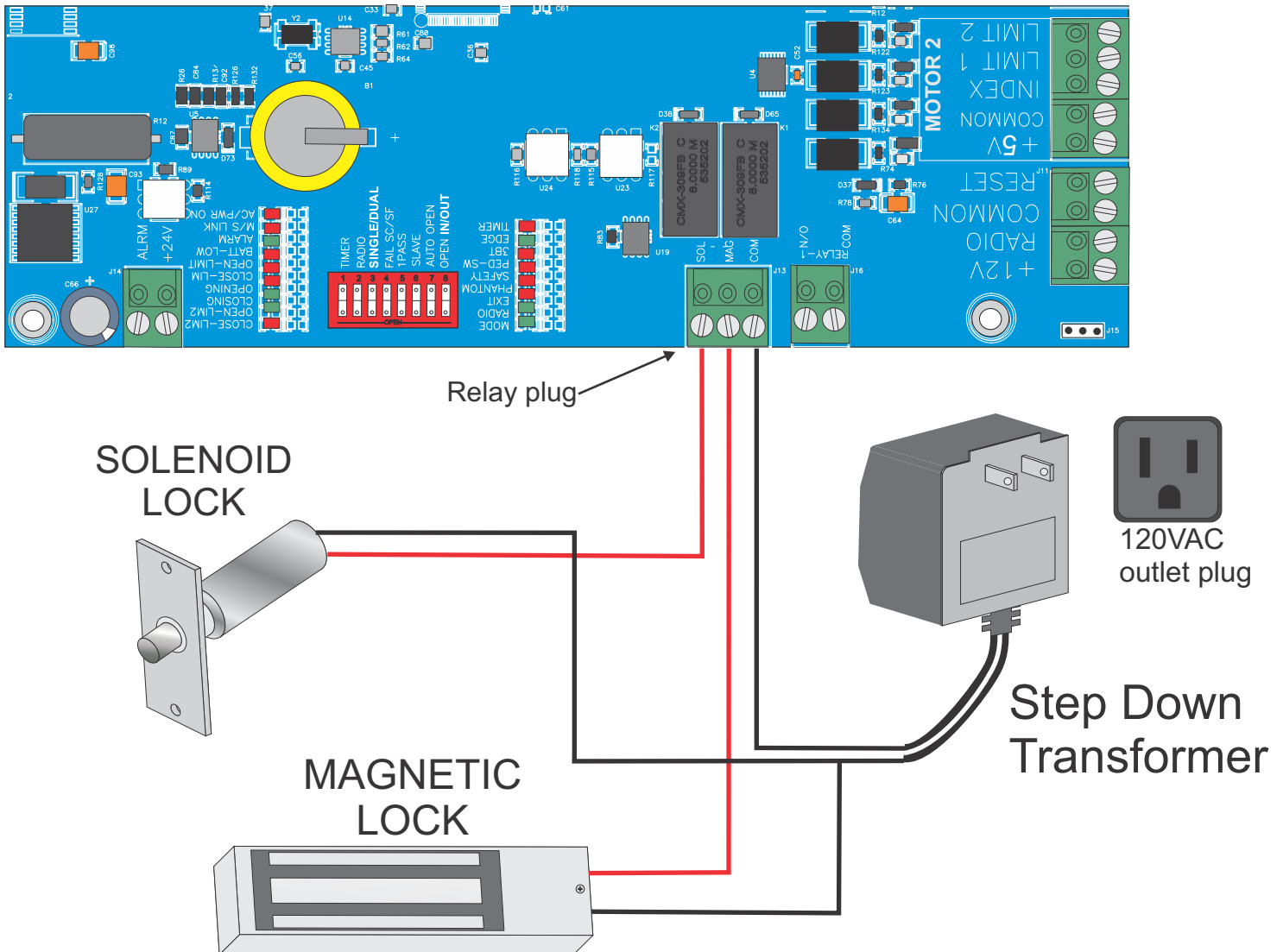



# RADIO RECEIVER CONNECTIONS

**4 wire receiver:** connect the two relay wires to common and radio terminals.

4 wire receiver: connect the two relay wires to common and radio terminals. Black (negative) wire to common and red (positive) wire to +12/24V terminal.

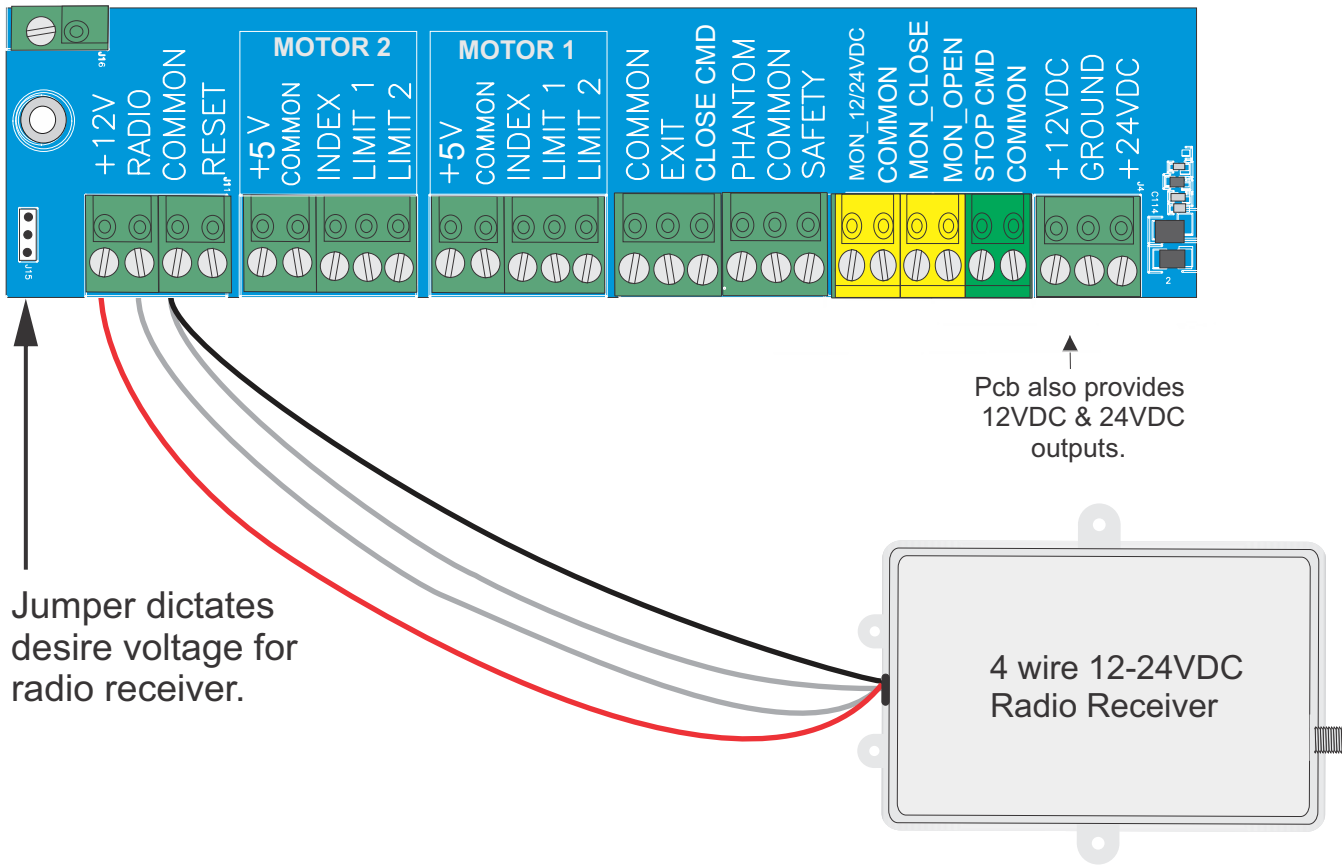

## OPEN AND CLOSE OBSTRUCTION SENSITIVITY ADJUSTMENT (ERD)

**ERD'S must be adjusted by qualified technician.**

ERD must be checked every six months.

The gate operator ERDs must be adjusted so that the gate provides regular, reliable and safe operation.

When gate stops and reverses by itself, the ERD is **too sensitive**.

The gate must stop and reverse when it hits an obstruction or the ERD is **not sensitive enough**.

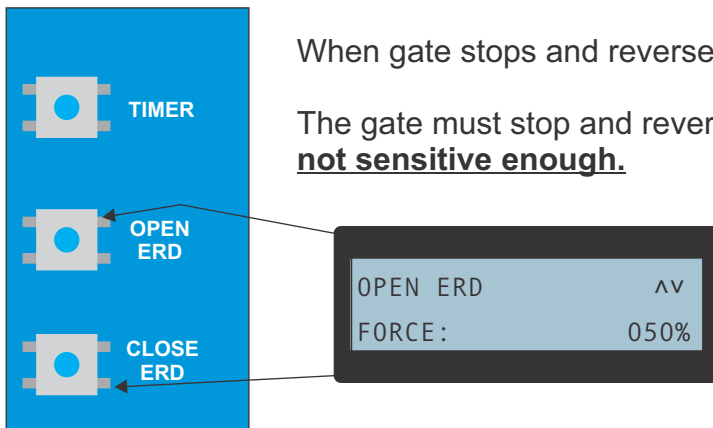

Each open and closed direction is adjusted individually. Press the OPEN ERD button. The display will wake-up in the OPEN ERD Setting. Use up/down buttons to increase or decrease the force. Press ENTER to save the value. Repeat the process for the CLOSE ERD by pressing the CLOSE ERD button.

# TIMER ADJUSTMENT

TIMER ON: Timer to close, can be set from 1 to 120 seconds.

TIMER OFF: Gate operation is push button to open, push button to close.

TO OVERRIDE THE TIMER: Turn the RADIO switch to the "ON" position. This will allow the radio receiver to close the gate before the timer.

## TIMER ADJUSTMENT

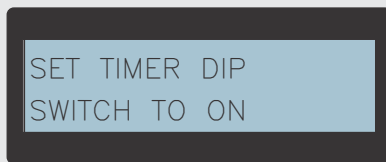
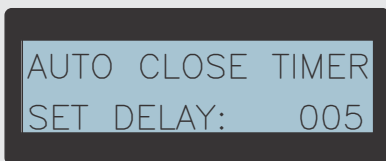

To adjust the delay for the auto close timer, press the TIMER push button. It will wake-up the display in the AUTO CLOSE TIMER DELAY.

Use up/down buttons to set desired delay time. Press ENTER to save the value. Range 1-120 sec. NOTE: If timer dip-switch is not ON, a message will be displayed saying "SET TIMER DIP SWITCH TO ON".

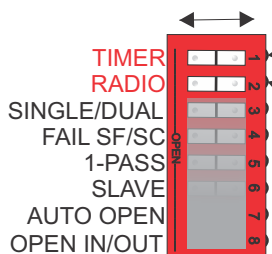

TIMER "ON" to activate the timer

RADIO "ON" = Allows the transmitter to close the gate before the timer.

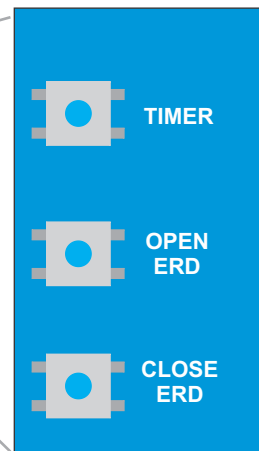
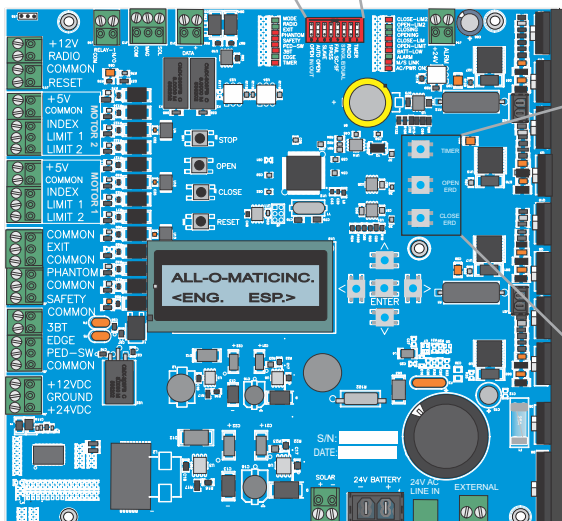

# DIP SWITCH FUNCTIONS

**NOTE:** Any changes to dip switches while power is **ON** requires you to reset the processor in order for board to read the change.

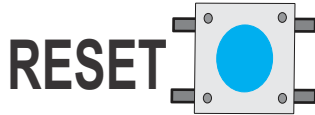

**RESET**

TIMER  
RADIO  
SINGLE/DUAL  
FAIL SF/SC  
1-PASS  
OSC  
AUTO OPEN  
OPEN IN/OUT

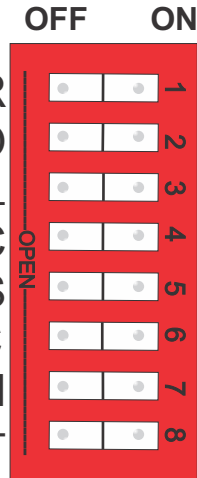

## TIMER

**TIMER** switch “**ON**” activates the **TIMER**. See page 31 for details

## RADIO

**RADIO** switch “**ON**” allows the radio receiver to override the timer. See page 31 for details.

## SINGLE/DUAL

This switch is used to select single or dual motor operation. **OFF** will only run motor 1 and **ON** will run motor 1 and motor 2.

## FAIL SF/SC

This is to set the operator as fail-safe or fail secure. **ON** for **Fail-safe**: on power failure, board will monitor battery voltage to make sure gate opens before battery drains out completely. **OFF** for **Fail-secure**: on power failure gate will run until battery is low and stay close.

## 1-PASS

This is a true one pass, anti-tailgating feature. This feature may only be used with safety loops. With this switch in the “**ON**” position, the gate will open until one car passes the safety loops then it will stop and close. If a second car pulls on the loop the gate will stop the car must then back off the loop before the gate will close.

## OSC

**OSC** switch “**ON**” allows the radio receiver to stop and reverse the gate in any direction. During a cycle, the first signal stops the gate. A second signal reverses the gate.

## AUTO OPEN

This feature is to automatic open the gate on power interruption. It is a very particular feature used in areas where the fire department requires the gate to open automatically after a power outage. Set this dip switch “**ON**” when this feature is desire.

## OPEN IN/OUT

This feature is to set the opening direction. **OFF** is to open in and **ON** to open out.

# SOLAR PANEL CONNECTIONS

The solar panel input will take a 12 or 24VDC panel or two 12VDC panels wired in series to make 24VDC. The on-board charger is limited to 80 watts. For applications that require more than 80 watts an external charger is required. See diagrams below for the different connection options.

**NOTE:** For information on solar panel calculation call ALL-O-MATIC or your local distributor for Assistance.

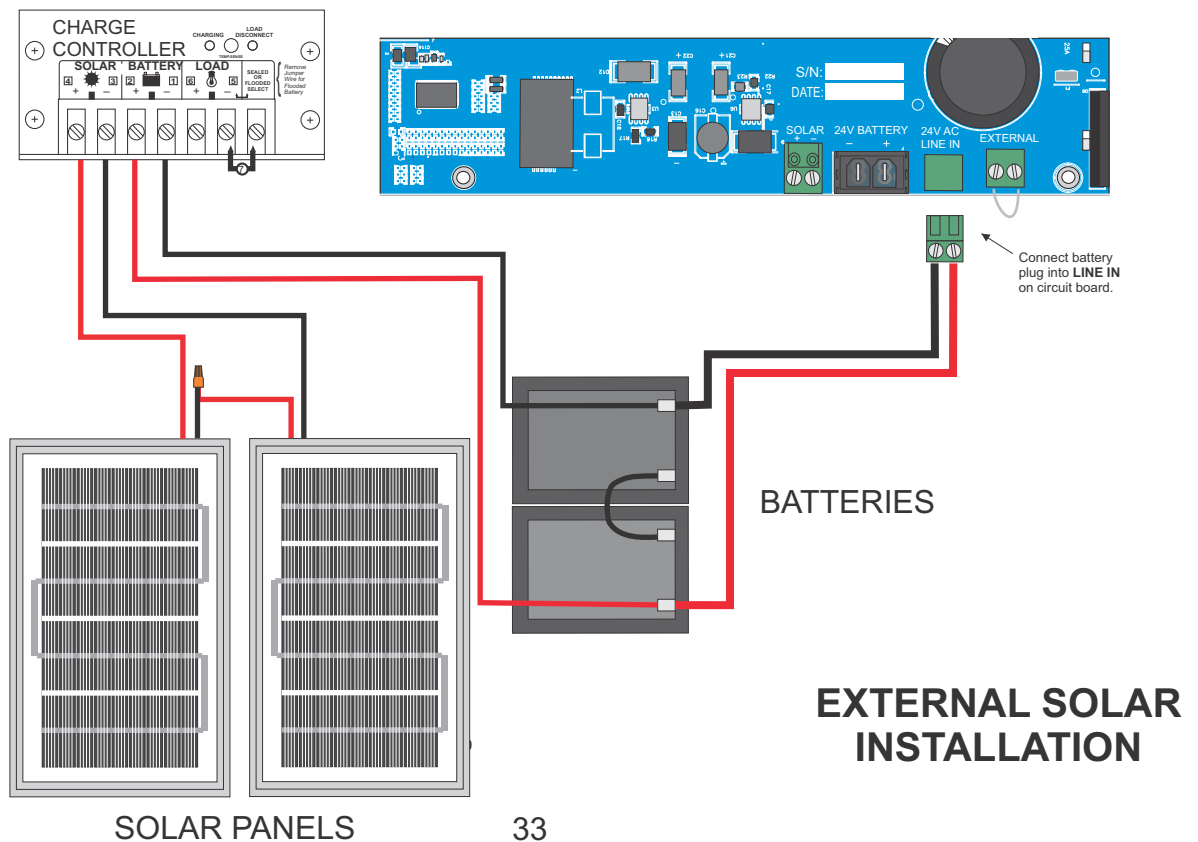
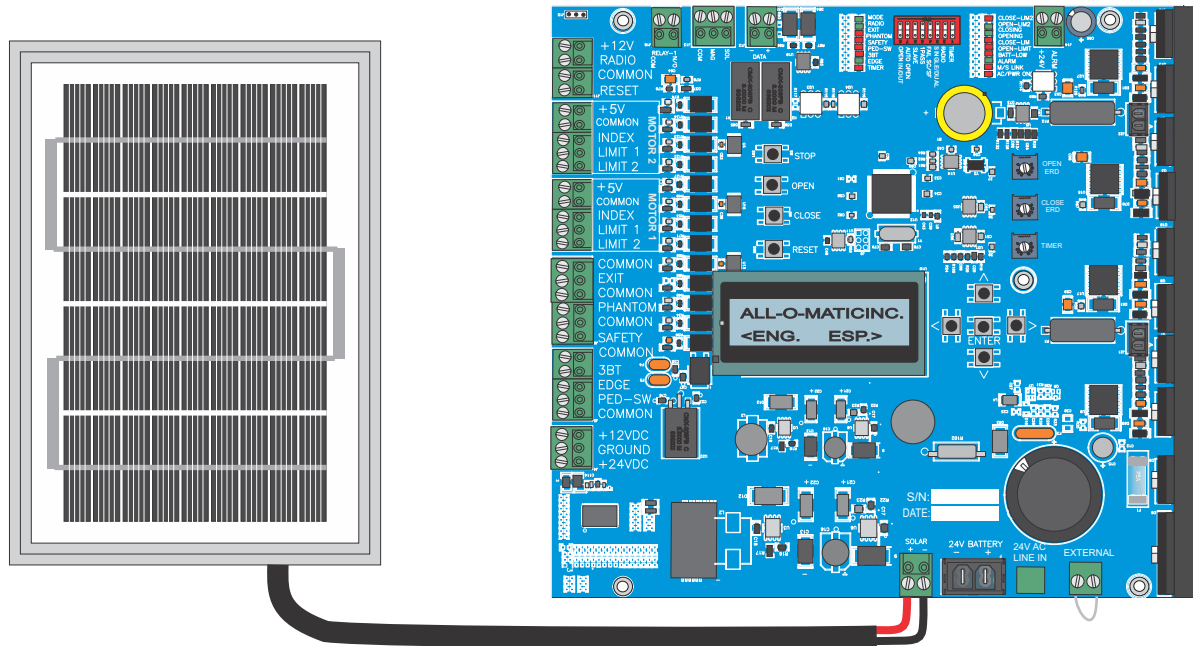

# LED DIAGNOSTICS

**AC/PWR ON:** Will be lit when power is present at LINE-IN power input.

**MON\_FAULT:** LED will turn on when a device on MON-OPEN or MON-CLOSE inputs does not respond correctly. Usually a mis-aligned or faulty photo eye would be the cause of this fault.

**ALARM:** Two states;

1st state: LED will blink (horn will beep also) every 30 seconds when battery is low, bad or disconnected.

2nd state: LED will turn on for 5 minutes when operator goes into shut down mode due to the gate bumping into an obstruction (E.R.D.). Also, the horn will go off for 5 minutes.

**BATT-LOW:** LED will be on solid when battery is low.

**OPEN LIM:** LED will be on while the open limit switch on MOTOR 1 is active.

**OPEN LIM2:** LED will be on while the open limit switch on MOTOR 2 is active.

**OPENING:** LED will be on while the board is sending power to either MOTOR 1 and/or MOTOR 2 for opening direction.

**CLOSING:** LED will be on while the board is sending power to either MOTOR 1 and/or MOTOR 2 for closing direction.

**CLOSE LIM:** LED will be on while the close limit switch on MOTOR 1 is active.

**CLOSE LIM2:** LED will be on while the close limit switch on MOTOR 2 is active.

**MODE:** Two states:

1st state: LED will blink slow (about every 2 seconds) when an overload occurs (over current).

2nd state: LED will blink fast (about every 1/2 second) when gate is jammed or motor sensors are not responding or disconnected.

**FIRE ACCESS:** LED will be on while fire access input is activated (closed circuit to common).

**RADIO:** LED will be on while radio input is activated (closed circuit to common).

**EXIT:** LED will be on while exit input or OPEN push button are activated (closed circuit to common).

**PHANTOM:** LED will be on while phantom input is activated (closed circuit to common).

**SAFETY:** LED will be on while safety input is activated (circuit is open from common).

**CLOSE\_CMD:** LED will be on while close cmd input is activated (closed circuit to common).

**MON\_CLOSE:** LED will be on while MON-CLOSE input is activated (circuit is open from common).

**MON\_OPEN:** LED will be on while MON\_OPEN input is activated (circuit is open from common).

**TIMER LED:** LED will blink when timer is counting down (on the open position only).

**STOP\_CMD:** LED will be on while STOP\_CMD input is activated (circuit is open from common).

**D8 LED:** Will be on solid when battery and AC/Solar are present and charger is active. If it's off or blinking, it means not enough power to charge batteries.

**D7 LED:** Will blink showing charging state of charger. The number of blinks tells the state of charge (1-3 states). If it's off, it means charger is not active.

# OPERATOR CURRENT DRAW & VOLTAGE DROP CHARTS

DC GATE OPERATORS	CURRENT DRAW @ 115VAC	CURRENT DRAW @ 220VAC
SL-45DC	2 AMPS	1 AMP
SL-90DC	5 AMPS	3 AMPS
SL-100FP DC	6 AMPS	3.5 AMPS
SL-150DC – ½ HP	4 AMPS	2 AMPS
SL-150DC – 1 HP	8 AMPS	4.5 AMPS
SL-175DC	9 AMPS	5 AMPS
TORO 24	4 AMPS	2 AMPS
SW-300DC	6 AMPS	3.5 AMPS
SW-325DC	6 AMPS	3.5 AMPS
SW-350DC – ½ HP	6 AMPS	3.5 AMPS
SW-350DC – 1 HP	8 AMPS	4.5 AMPS
SW-375DC	8 AMPS	4.5 AMPS
OH-200DC	6 AMPS	3.5 AMPS

Max Wire Feet @ 120 Volts, 1 Phase, 2% Max Voltage Drop						
Amps	Volt- Amps	#14	#12	#10	#8	#6
1	120	450	700	1100	1800	2800
5	600	90	140	225	360	575
10	1200	45	70	115	180	285
15	1800	30	47	75	120	190
20	2400	œ	36	57	90	140
25	3000	œ	œ	45	72	115
Amps	Volt- Amps	#4	#2	1/0	2/0	3/0
1	120	4500	7000	œ	œ	œ
5	600	910	1400	2250	2800	œ
10	1200	455	705	1100	1400	1800
15	1800	305	485	770	965	1200
20	2400	230	365	575	725	900
25	3000	180	290	460	580	720

Max Wire Feet @ 240 Volts, 1 Phase, 2% Max Voltage Drop						
Amps	Volt- Amps	#14	#12	#10	#8	#6
1	240	900	1400	2200	3600	5600
5	1200	180	285	455	720	1020
10	2400	90	140	225	360	525
15	3600	60	95	150	240	350
20	4800	œ	70	110	180	265
25	6000	œ	œ	90	144	210
Amps	Volt- Amps	#4	#2	1/0	2/0	3/0
1	240	9000	œ	œ	œ	œ
5	1200	1750	2800	4500	5600	7000
10	2400	910	1400	2200	2800	3600
15	3600	605	965	1500	1900	2400
20	4800	455	725	1100	1400	1800
25	6000	365	580	920	1100	1440

ITEM NO.	QTY.	PART NUMBER	ITEM NO.	QTY.	PART NUMBER
1	1	T24-001, REV 17, MAIN HEAD HOUSING, BOTTOM	41	3	HX-SHCS 0.25-20x0.75x0.75-S
2	1	T24-002, REV 17, MAIN HEAD HOUSING, TOP	42	16	Hi Collar LW 0.25
3	1	T24-003, REV 4, COVER, HOUSING ELECTRICAL	43	8	Hi Collar LW 0.138
4	1	T24-004, REV 4, MOTOR BRACKET	44	3	HX-SHCS 0.138-32x0.4375x0.4375-N
5	1	T24-005, REV 2, DRIVE ADAPTER	45	3	B18.3.5M - 5 x 0.8 x 12 Socket FCHS - 12N
6	2	T24-006, REV 1, MITER GEAR, 10 PITCH, 20 TEETH	46	1	HX-SHCS 0.164-32x0.75x0.75-S
7	1	T24-007, REV 4, GEARBOX SHAFT	47	1	Hi Collar LW 0.164
8	1	T24-008, REV 3, WORM GEAR			
9	1	T24-009, REV 2, GEARBOX RELEASE PIN			
10	1	T24-010, REV 1, GEARBOX RELEASE KEY			
11	1	T24-011, REV 2, BRONZE BEARING			
12	1	T24-012, REV 1, WORM			
13	1	T24-013, REV 1, GEARBOX RELEASE PIN			
14	1	T24-014, REV 2, SPACER, DRIVE ADAPTER			
15	2	T24-015, REV 1, SPACER, DRIVE ADAPTER, MITER GEAR			
16	1	T24-016, REV 1, GEARBOX RELEASE SPRING			
17	2	T24-017, REV 1, BEARING CLAMP, 6203 BEARING			
18	1	T24-018, REV 2, BEARING CLAMP, 6202 BEARING			
19	1	T24-019, REV 4, BEARING CLAMP			
20	1	T24-020, REV 3, CAM PIVOT			
21	1	T24-021, REV 4, GEAR LEVER CAM			
22	1	T24-022, REV 1, LOCK BOLT			
23	1	T24-023, REV 9, HANDLE			
24	1	T24-024, REV 3, CAP, LOCK			
25	1	T24-042, REV 1, LEVER COVER			
26	2	5972K440_BALL BEARING			
27	1	MOTOR, 64110			
28	1	91590A126_STAINLESS STEEL EXTERNAL RETAINING RING			
29	1	91590A128_STAINLESS STEEL EXTERNAL RETAINING RING			
30	1	5972K357_BALL BEARING			
31	1	91585A448_METRIC 18-8 STAINLESS STEEL DOWEL PIN			
32	2	98490A160_METRIC STEEL WOODRUFF KEY			
33	1	90967A180_STAINLESS STEEL EXTERNAL RETAINING RING			
34	1	heyco-m4340			
35	1	heyco-m9134-m9135			
36	1	91590A125_STAINLESS STEEL EXTERNAL RETAINING RING			
37	1	E2005, REV 2, LOCK CYLINDER			
38	14	HX-SHCS 0.25-20x1x1-S			
39	1	CR-PHMS 0.138-32x0.375x0.375-N			
40	2	CR-PHMS 0.138-32x0.4375x0.4375-S			

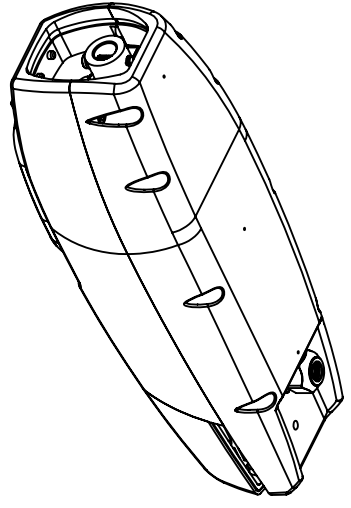
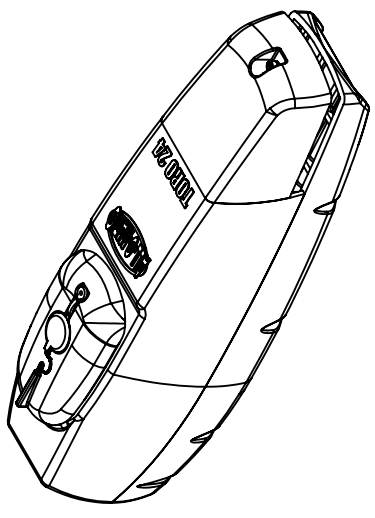
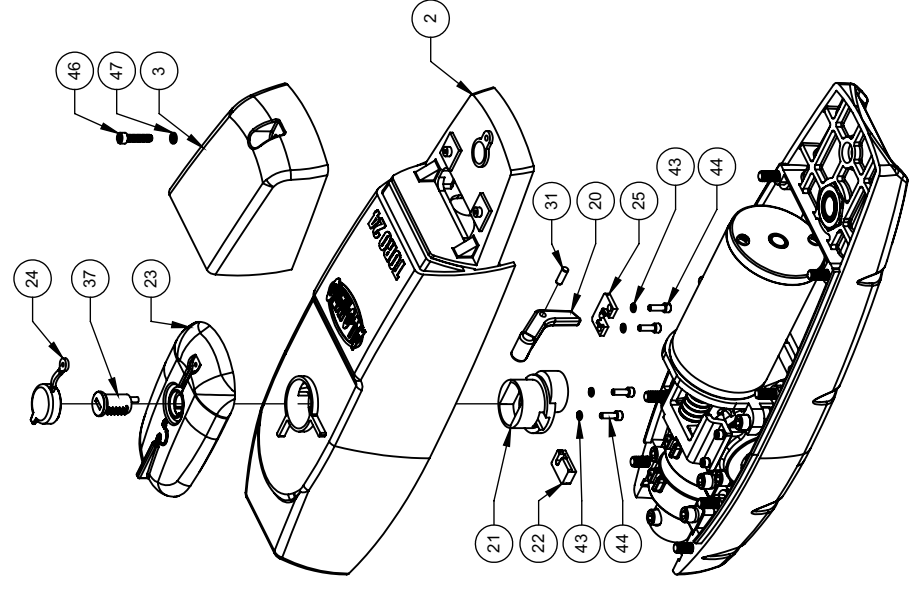

ALL-O-MATIC, Inc.

DIMENSIONS ARE IN MILLIMETERS  
BREAK SHARP EDGES 10-40  
MACHINED SURFACE FINISH IS  
AS SHOWN  
DO NOT SCALE DRAWING  
DRAWN: FTA  
CHECKED: X  
DATE: 1/27/19  
SCALE: 1:3  
SHEET 1 OF 3  
DRAWING SEE: B  
PART#: T24-025

1		PROTOTYPE RELEASE	FTA	1/27/19
	ECO#	ENGINEERING CHANGE ORDER DESCRIPTION	BY	DATE

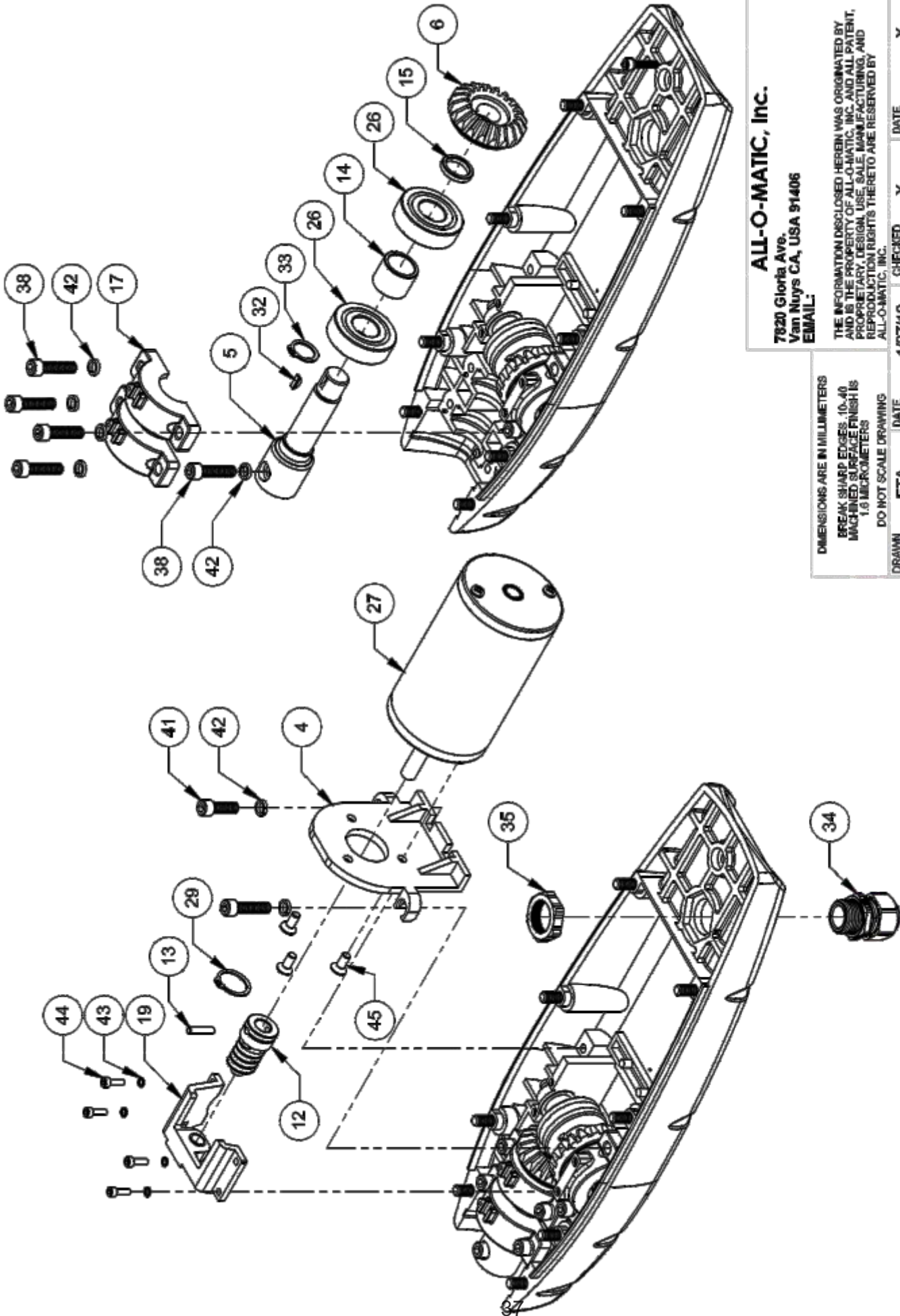

**ALL-O-MATIC, Inc.**  
 7820 Gloria Ave.  
 Van Nuys CA, USA 91406  
 EMAIL:

THE INFORMATION DISCLOSED HEREIN WAS ORIGINATED BY AND IS THE PROPERTY OF ALL-O-MATIC, INC. AND ALL PATENT, PROPRIETARY, DESIGNAL, USE, SALE, MANUFACTURING, AND REPRODUCTION RIGHTS THERETO ARE RESERVED BY ALL-O-MATIC, INC.

DIMENSIONS ARE IN MILLIMETERS  
 BREAK SHARP EDGES: 10-40  
 MACHINED SURFACE FINISH IS  
 1.6 MICROMETERS  
 DO NOT SCALE DRAWING

DRAWN BY:	FTA	DATE DRAWN:	1/27/19	CHECKED BY:	X	DATE CHECKED:	X
MATERIAL:							
RAWMAT:							

1	PROTOTYPE RELEASE	FTA	1/27/19	TITLE	MAIN HOUSING ASSY		
SYMBOL	ECO#	BY	CND	DATE	SHEET	SCALE	DRAWING SIZE
					2 OF 3	1:3	A
	ENGINEERING CHANGE ORDER REVISION DESCRIPTION						PART#
							T24-025



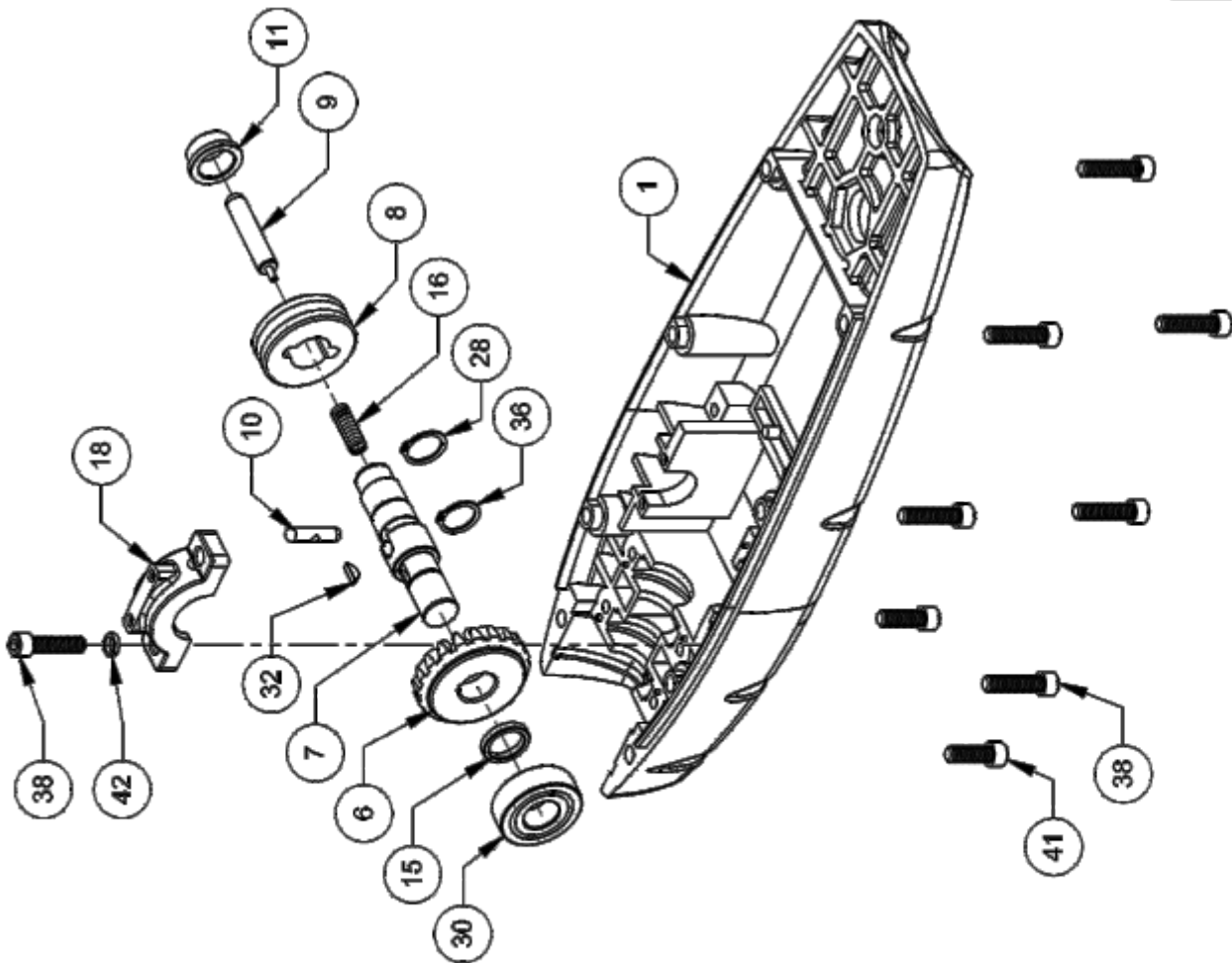

**ALL-O-MATIC, Inc.**  
 7820 Gloria Ave.  
 Van Nuys CA, USA 91406  
 EMAIL:

THE INFORMATION DISCLOSED HEREIN WAS ORIGINATED BY AND IS THE PROPERTY OF ALL-O-MATIC, INC. AND ALL PATENT, PROPRIETARY, DESIGNAL, USE, SALE, MANUFACTURING, AND REPRODUCTION RIGHTS THERETO ARE RESERVED BY ALL-O-MATIC, INC.

DIMENSIONS ARE IN MILLIMETERS  
 BREAK SHARP EDGES: 10-40  
 MACHINED SURFACE FINISH IS  
 1.6 MICROMETERS  
 DO NOT SCALE DRAWING

DRAWN BY: **FTA** DATE DRAWN: **1/27/19** CHECKED BY: **X** DATE CHECKED: **X**  
 MATERIAL: **RAWMAT:**

1	PROTOTYPE RELEASE	FTA	1/27/19	DATE	<b>MAIN HOUSING ASSY</b>	
SYMBOL	ECO#	BY	CKD	DATE	SHEET <b>3</b> OF <b>3</b>	SCALE: <b>1:3</b>
	ENGINEERING CHANGE ORDER REVISION DESCRIPTION				DRAWING SIZE: <b>A</b>	PART#: <b>T24-025</b>

# OPERATOR PARTS DIAGRAM

ITEM NO.	QTY.	PART NUMBER
1	1	T24-027, REV 2, DRIVE HOUSING
2	1	T24-028, REV 1, SHAFT TUBE, STAINLESS STEEL
3	1	T24-029, REV 2, DRIVE SCREW SHAFT
4	1	T24-030, REV 2, END CAP, DRIVE HOUSING
5	1	T24-031, REV 2, PLASTIC BEARING FLANGE
6	1	T24-032, REV 2, PLASTIC NUT, DRIVE SHAFT
7	2	T24-033, REV 1, LIMIT SWITCH ASSY
8	1	T24-038, REV 2, ATTACHMENT HEAD
9	1	T24-039, REV 2, COVER, DRIVE HOUSING
10	1	T24-040, REV 1, SEAL, COVER
11	1	T24-041, REV 3, LIMIT RAIL
12	1	T24-043, REV 1, BUSHING, DELRIN
13	1	91585A954, DOWEL PIN, 12 mm DIA x 30 mm LG
14	3	CR-PHMS 0.112-40x0.25x0.25-N
15	4	CR-PHMS 0.138-32x0.5x0.5-N
16	1	HX-SHCS 0.19-24x0.375x0.375-N
17	1	HX-SHCS 0.19-24x0.875x0.875-N
18	1	MSHXNUT 0.190-24-S-N
19	1	PAN HEAD SELF TAPPING SCREW, #4 x 3/4" LG

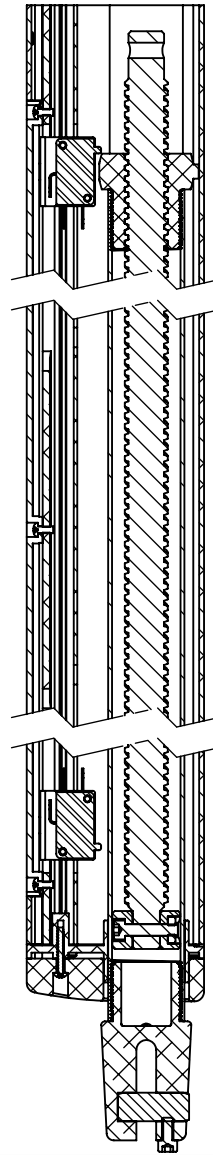
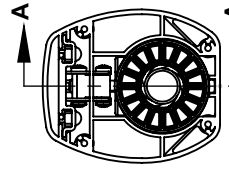
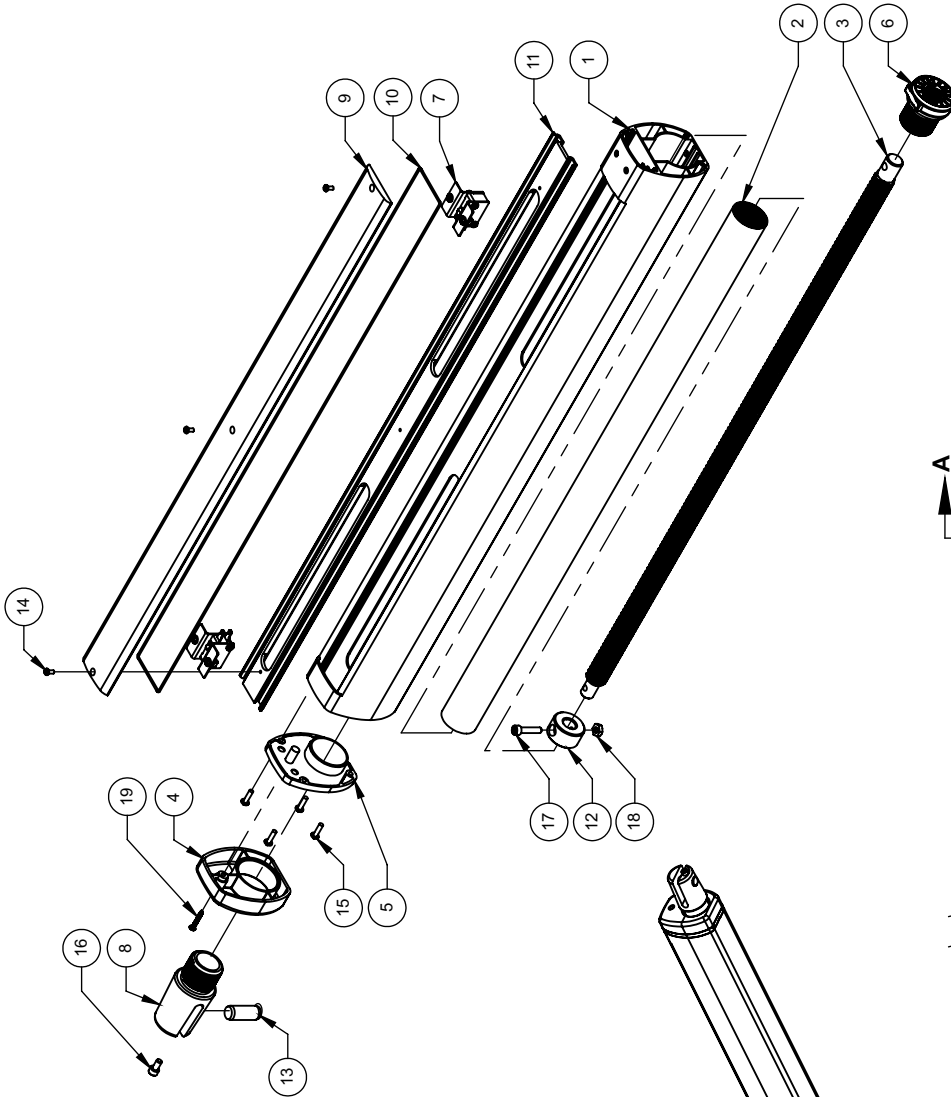

ALL-O-MATIC, Inc.

DIMENSIONS ARE IN MILLIMETERS  
BREAK SHARP EDGES 10-40  
MACHINED SURFACE FINISH IS  
1.8 MICROMETERS  
DO NOT SCALE DRAWING

THE INFORMATION DISCLOSED HEREIN WAS ORIGINATED BY  
AND IS THE PROPERTY OF ALL-O-MATIC, INC. AND ALL PATENT,  
RIGHTS AND REPRODUCTION RIGHTS THERE TO ARE RESERVED BY  
ALL-O-MATIC, INC.

DRAWN BY	FTA	DATE	2/1/19	CHECKED BY		DATE	
MATERIAL							
REVISION							

TITLE:	DRIVE HOUSING ASSY
SHEET	1 OF 1
SCALE:	1:4
DRAWING SIZE:	B
PART#:	T24-026

BY		DATE	2/8/19
ENGINEERING CHANGE ORDER DESCRIPTION			
SYMBOL	EQW	PROTOTYPE RELEASE	

SECTION A-A	SCALE 1:2
-------------	-----------





---

VAN NUYS, CA 91406

ALLOMATIC.NET