



Intertek

UL-325 **6th edition**,
UL-991 & CSA C22.2
#247 Compliant

OH-200AC Installation Manual

TABLE OF CONTENTS

SAFETY AND INTRODUCTION

Safety Instructions	3-4
UL 325 Cass Types	5
Operator Specifications	6

INSTALLATION

Operator Dimensions	7
Operator Installation	8
Mounting Instructions	9
Entrapment Protection Installation	10
Loop Layout	11
Electrical Connection	12
Gate Travel Adjustment	13

BOARD FEATURES

Gate Opening Direction Setting	14
Programmable Relay and Leaf Delay	15
Timer Adjustment and Radio Setting	16
Dip Switch Functions	17
Electronic Reversing Device (ERD) Adjustment	18

WIRING ACCESSORIES TO CONTROL BOARD

Accessory Connections	19
Monitored Entrapment Protection Device Connection	20-21
Three-Button Station Connection	22
Radio Receiver Connection	23

BREATHING CAP PIN	24
------------------------------------	----

EMERGENCY RELEASE INSTRUCTIONS	25
---	----

WARRANTY AND CUSTOMER RECORD	26
---	----

PARTS BREAKDOWN

Blowout Drawing	Check Website
---------------------------	---------------

IMPORTANT SAFETY INSTRUCTIONS

WARNING

TO REDUCE THE RISK OF **INJURY**:

READ AND FOLLOW ALL INSTALLATION INSTRUCTIONS. DO NOT START INSTALLATION UNTIL YOU HAVE READ AND UNDERSTAND THESE DIRECTIONS. IF THERE IS SOMETHING YOU DO NOT UNDERSTAND, PLEASE CALL US.

NEVER let children operate or play with gate controls.

Locate the control station and make sure it is (a) within sight of the gate and (b) at a minimum height of 5 feet so small children cannot reach it.

Install the enclosed entrapment warning signs next to the control station and in a prominent location.

For operators equipped with a manual release, instruct the end user on the correct operation of the manual release. Use the manual release only when the gate is not moving. It is advised that the power be turned off.

Always keep people and objects away from the gate. No one should cross the path of a moving gate.

The gate operator must be tested monthly. The gate must reverse on contact with a rigid object, or stop when an object activates the non-contact sensor(s). Always re-test the operator after adjusting the limits and/or force. Failure to adjust and re-test the gate operator properly may cause severe injury or death.

Keep gate(s) properly maintained. Have a qualified service technician make repairs to gate hardware and make proper adjustments to gate operator.

This gate entrance/exit is for vehicles only. Pedestrians must use a separate entrance.

There is nothing on a gate operator that is easily repaired or adjusted without a great deal of experience. Call a qualified gate service technician who knows your gate operator.

SAVE THESE INSTRUCTIONS

INSTALL THE GATE OPERATOR ONLY WHEN YOU HAVE READ THE FOLLOWING

BEFORE GATE OPERATOR INSTALLATION

- Confirm that the gate operator being installed is appropriate for the application.
- Confirm that the gate is designed and built according to the current published industry standards.
- Confirm that all appropriate safety features and safety accessory devices are being installed, including all entrapment protection devices.
- Make sure that the gate opens and closes freely (by hand) before installing the operator.
- Repair or replace worn or damaged gate hardware before installing the gate operator.
- Eliminate all gaps in the sliding gate below a 6 foot height that permits a 2 1/4" sphere to pass through any location. This includes the area of the adjacent fence covered when the gate is in the open position
- Eliminate all gaps in a swing gate below a 4 foot height that permits a 4" sphere to pass through any location. This includes the hinge area of the gate.
- Install a proper electrical ground to the gate operator.
- Controls intended for user activation must be located at least 6 feet away from any moving part of the gate, and where the user is prevented from reaching over, under, around, or through the gate to operate the controls.
- Outdoor or easily accessible controls shall have a security feature to prevent unauthorized use.
- The stop and/or reset button must be located in the line of sight of the gate. Activation of the operator reset control shall not cause the operator to move.
- Install a minimum of 2 warning signs, one on each side of the gate where they are easily visible.
- Take pictures of the installation.
- Test all safety features for proper function before placing the automatic vehicular gate in operation.

GATE OPERATOR INSTALLATION

- Operator must be disconnected from the power source before attempting any installation of accessories.
- Install gate operator according to the installation instructions in this manual.
- Adjust the operator clutch or load sensing device to the minimum force setting that will allow for reliable gate operation.
- Install the operator inside the fence line. Do not install the operator on the public side of the fence line.

MAINTENANCE

- Train owners/users on the basic functions and safety features of the gate system, including how to turn off the power and operate the manual disconnect feature.
- Leave safety instructions, product literature, installation manual, and maintenance manual with the owner or end user.
- Explain to the owner or end user the importance of routine service and operator testing on a monthly basis.

UL 325 CLASS TYPES AND OBSTRUCTION SENSING SYSTEMS

Each class must have (2) monitored entrapment protection devices in each entrapment zone to sense and react to obstructions within 2 seconds.

All-O-Matic's gate operators conform to the most rigid Class One.

UL 325 CLASS TYPES

CLASS ONE: RESIDENTIAL

- A vehicular gate operator intended for use in garages or parking areas associated with a residence of one to four single families.

CLASS TWO: COMMERCIAL OR GENERAL PUBLIC ACCESS

- A vehicular gate operator intended for use at a commercial location or building, such as a multi-family housing units (five or more single family units), hotels, garages, retail stores, or other buildings accessible by or servicing the general public.

CLASS THREE: INDUSTRIAL OR LIMITED ACCESS

- A vehicular gate operator intended for use at an industrial location or building, such as a factory, loading dock area, or other location not accessible by or intended to service the general public.

CLASS FOUR: RESTRICTED ACCESS

- A vehicular gate operator intended for use at a guarded industrial location or building, such as airport security areas or other restricted access locations not servicing the general public and where unauthorized access is prevented via supervision by security personnel.

THE SIX TYPES OF OBSTRUCTION SENSING SYSTEMS

TYPE A:

- Inherent entrapment protection system. This system must sense and initiate the reverse of the gate within 2 seconds of contact with a solid object.

TYPE B1:

- Non-contact sensor (photoelectric sensor or equivalent). This system shall, upon sensing an obstruction in the direction of the gate travel, reverse the gate within a maximum of 2 seconds.

TYPE B2:

- Contact sensor (edge device or equivalent). This system shall, upon sensing an obstruction in the direction of the gate travel, initiate the reversal of the gate within a maximum of 2 seconds.

TYPE C:

- Inherent force limiting, inherent adjustable clutch, or pressure relief valve.

TYPE D:

- Actuating device requiring continuous pressure to maintain opening or closing motion of the gate.

SPECIFICATIONS

	OH-200 AC
Max Gate Weight	800 lbs.
Max Gate Length	20'
Warranty	5 year commercial
Motor	1/2 HP
Gate Speed	Approximately 15 seconds per opening 6.5' to 8' high gate
Power	115 VAC single phase 4.7 amps
Duty Cycle	Continuous
Temperature Range	-40° to 160°
Gear Box Ratio	40:1
Dimesions	13" W X 144" L X 8" H (Custom rail lengths available)
Shipping Weight	100 lbs.
Emergency Release	Lockable quick release drive arm and carriage
Belt Size	4L-200
Main Sprocket	41B15 x 5/8" bore
Chain Size	41NP
Gear Box Sprocket	N/A
Limit Shaft Sprocket	N/A
Breaker Requirement	20 amp dedicated
Gearbox Pulley	2.5" with 1/2" bore
Motor Pulley	2" with 5/8" bore
UL Classes	I & II

OPERATOR DIMENSIONS

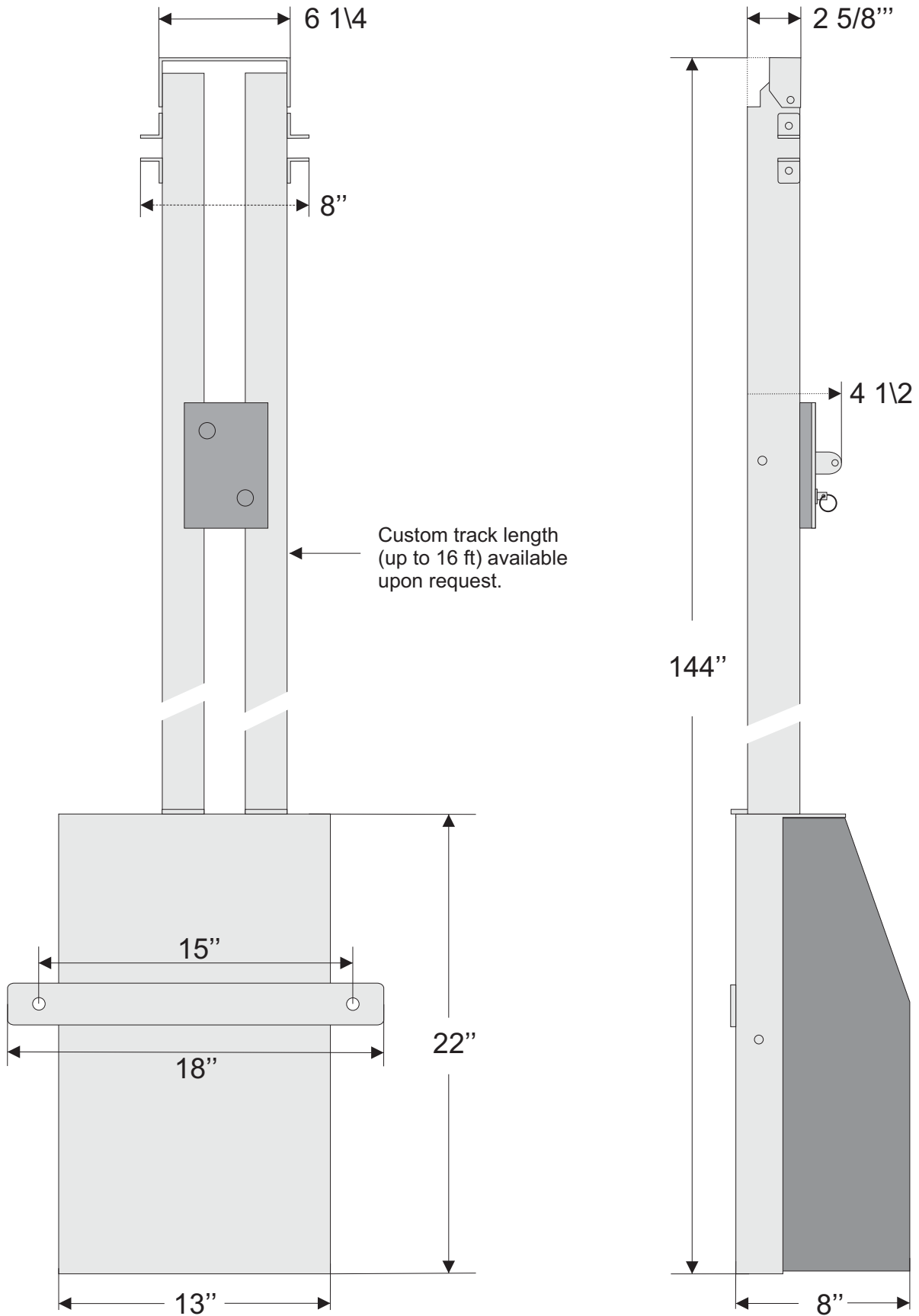

OPERATOR INSTALLATION

Note: Make sure the gate hardware is well balanced. The gate should open and close smoothly.

With gate closed, mark the center of the gate.

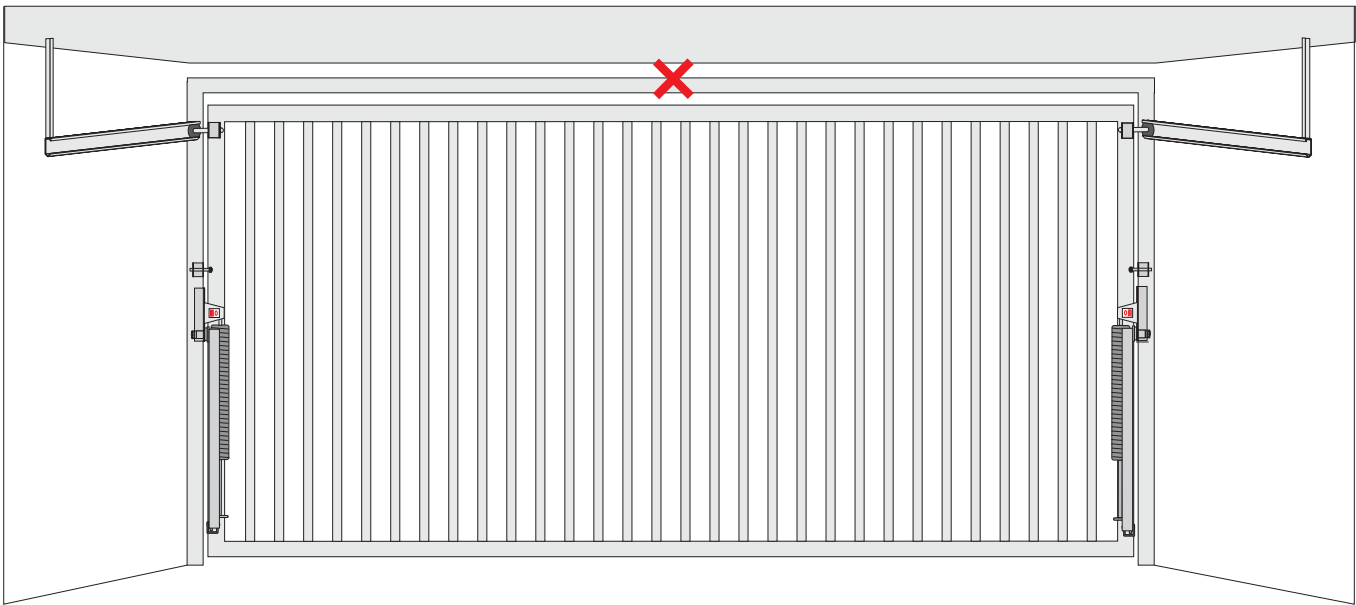

Lift gate to open position and mark the center point of the gate for the operator on the ceiling.

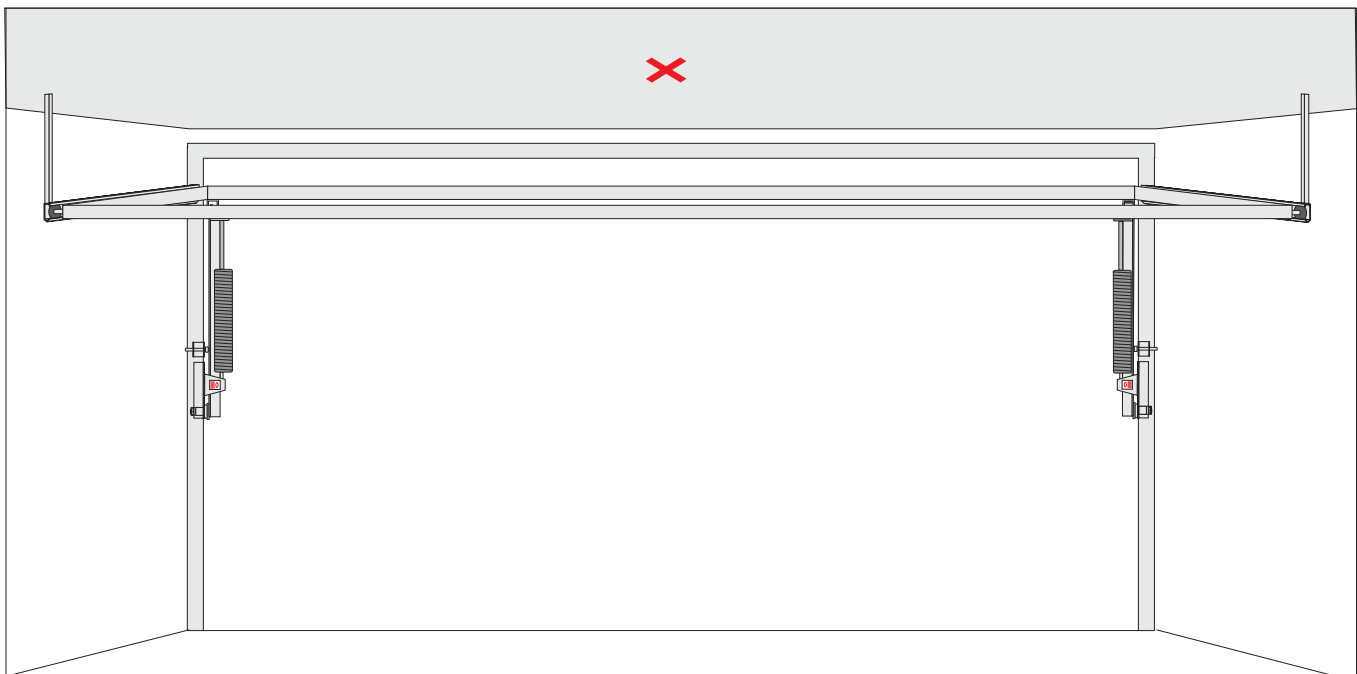

MOUNTING INSTRUCTIONS

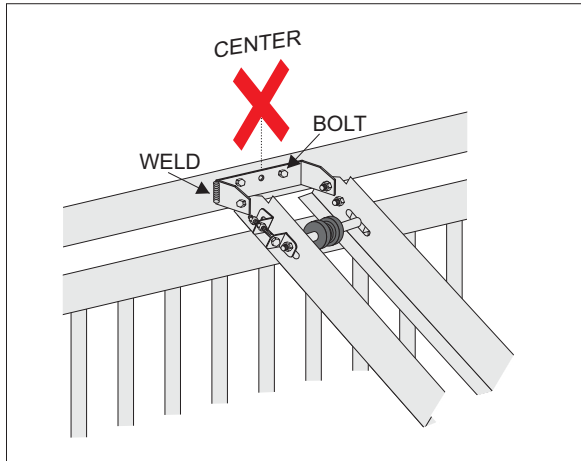

Make sure the end bracket is in the center of the opening. Bolt or weld the end bracket to wall. The operator bracket must be at least 2.5" above the gate.

Level and align the gate operator tracks before mounting them to the ceiling. Manufacture ceiling brackets to weld or bolt the operator in place (not provided).

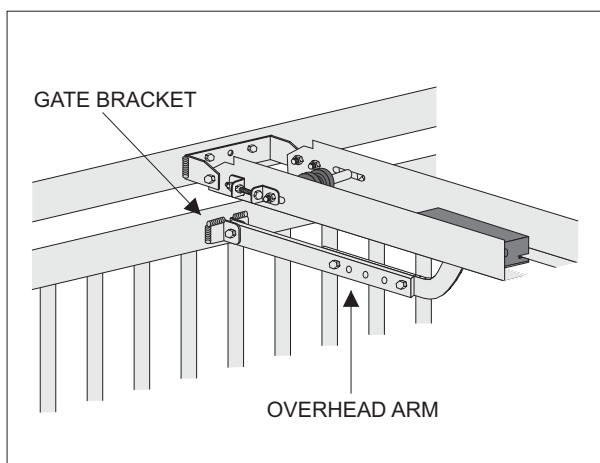
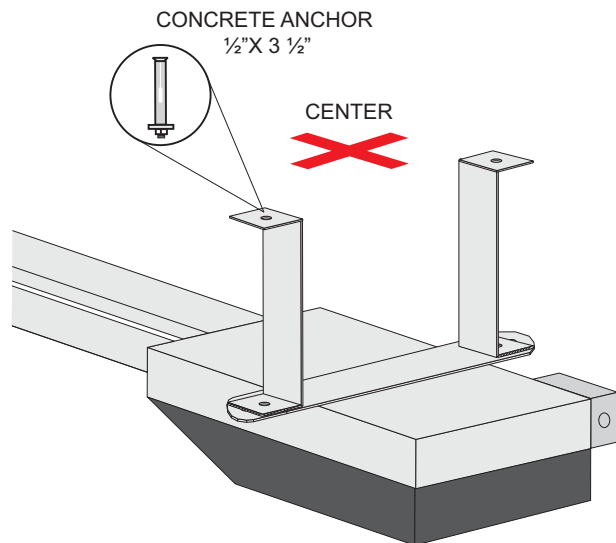

Connect the overhead arm, insure alignment, and weld the gate bracket in place.

ENTRAPMENT PROTECTION INSTALLATION

- A minimum of (2) monitored entrapment protection devices are **REQUIRED** for each entrapment zone.
- An entrapment zone is a location or point of contact where a person can become entrapped between a moving gate and a rigid object.
- The operator is equipped with an inherent entrapment protection system (ERD).
- The gate operator requires an external monitored entrapment protection device (non-contact photoelectric sensor or contact edge) for each entrapment zone prior to gate operation. The operator cycles power to the external entrapment protection device and checks for device signals. If the operator does not receive the correct feedback from the device, the gate will not operate.

OUTSIDE PROPERTY LOOKING IN

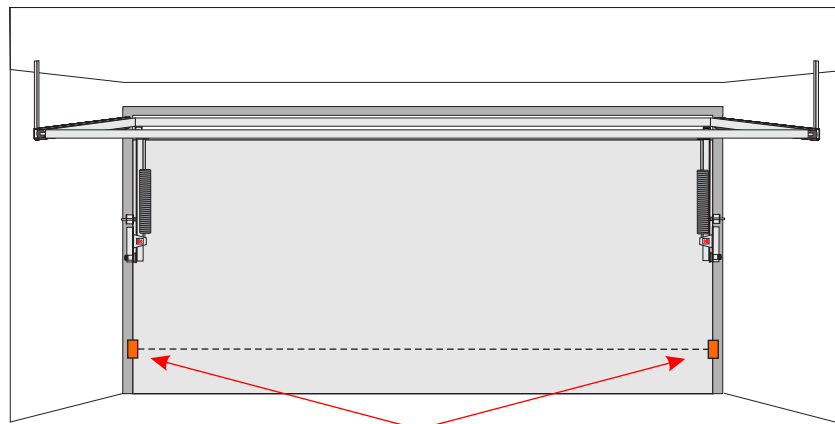

PHOTOELECTRIC SENSOR FOR CLOSE CYCLE

SIDE VIEW

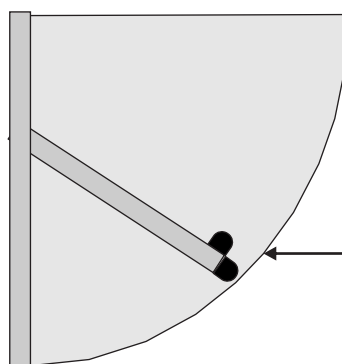

EDGE SENSOR FOR OPEN CYCLE. INSTALL HORIZONTALLY ON BOTTOM AND/OR FRONT OF GATE FRAME

LOOP LAYOUT

- Below is a typical loop layout. When connecting to an All-O-Matic circuit board, use the following:
 - Safety Loop - Normally Closed (N.C) Contacts
 - Exit Loop - Normally Open (N.O.) Contacts
- Wires **MUST** be twisted from the exit point of the loop saw cut to the gate operator.
- Twist loop wires 6 turns per foot, as shown below. Improper twisting of wires can cause loop issues.
- When using an inside and outside safety loop, loops must be **WIRED IN SERIES**.

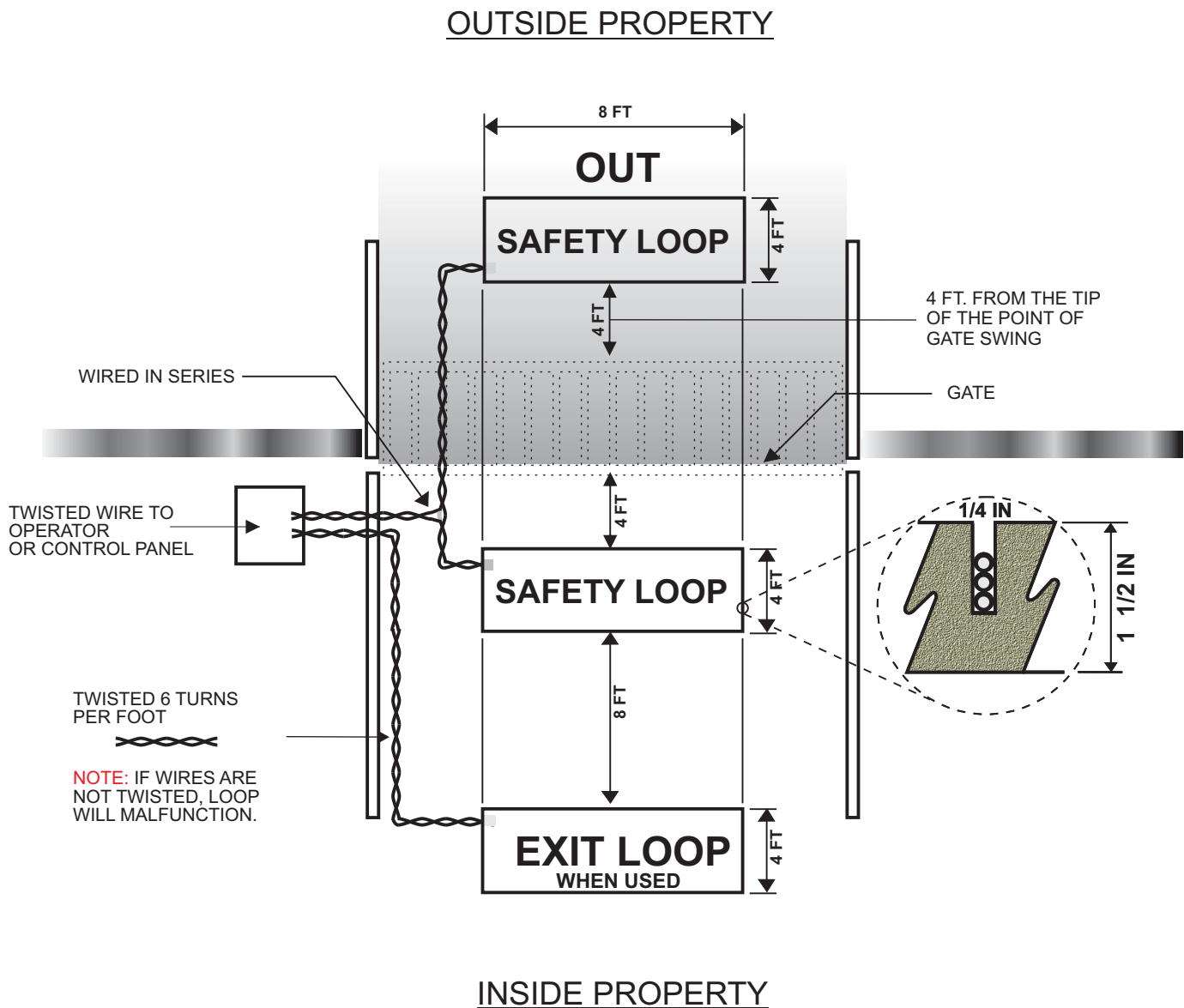

ELECTRICAL CONNECTION

OPERATORS **MUST** BE PROPERLY GROUNDED!

- All gate operators **MUST** be properly grounded. This minimizes or prevents damage due to electrical charge, such as a near lightning strike or an electrical static discharge.
- Use a single wire for the ground. **DO NOT** splice two wires for the ground. If the wire breaks or is cut, replace it with a single length wire. **NEVER** use two wires for the ground.
- Check the local city code for proper earth ground rod type and grounding procedures.
- Use UL listed conduits for power wire enclosure.

- Use a minimum of a **20-AMP**, dedicated circuit for power.

Operator wires	120 VAC FROM BREAKER
BLACK	120VAC (HOT)
WHITE	AC NEUTRAL
GREEN	GROUND

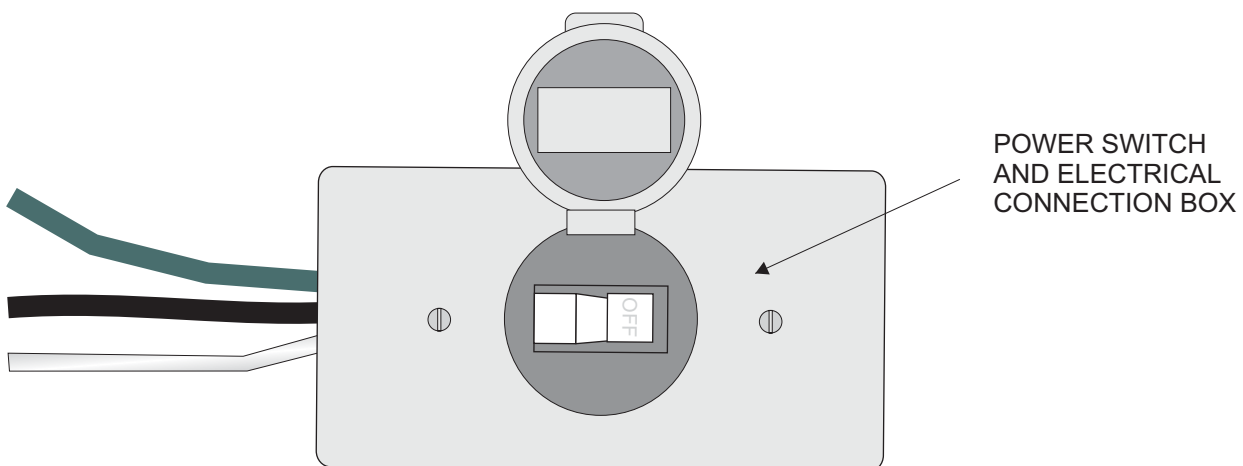

GATE TRAVEL ADJUSTMENT

Locate the limit switches and follow the steps below:

- 1: Stop the gate operator in the desired position using the 3 button station on the control board. Turn the power **OFF** to the operator.
- 2: Push the limit lock plate down.
- 3: Turn the limit nut toward the switch to **DECREASE** travel and away from the switch to **INCREASE** travel.
- 4: Place limit plate back to its locked position. (**MUST** be done for gate to hold its limits)
- 5: Turn the power **ON** to the operator.
- 6: Run the gate operator open and close. If additional adjustment is needed, repeat the steps.

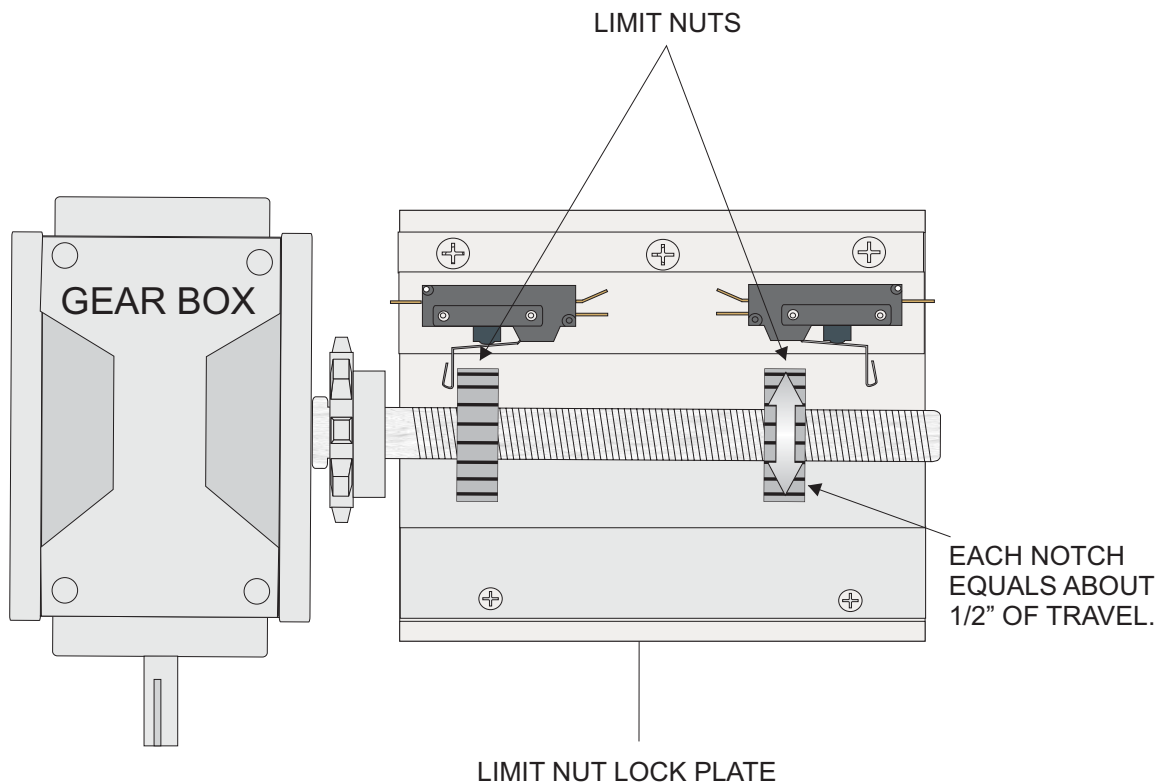

GATE OPENING DIRECTION SETTING

- Use OPEN L/R” dipswitch (#8) to change the opening direction of the operator.
- LEDs will show opening and closing direction when the gate is moving.
- OPEN L/R switch should be set to “ON” for an overhead operator.

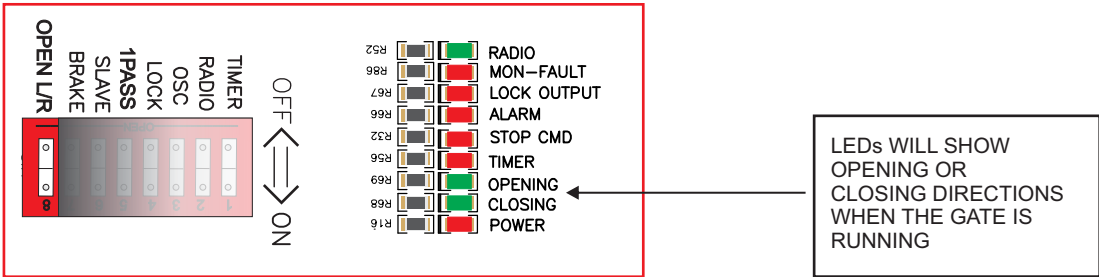

LEDs WILL SHOW OPENING OR CLOSING DIRECTIONS WHEN THE GATE IS RUNNING

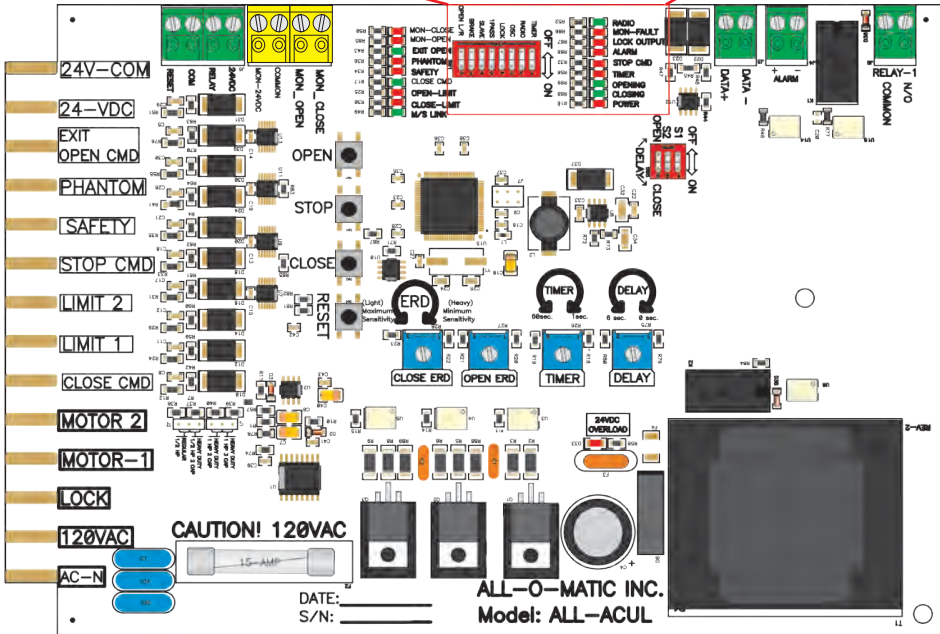

PROGRAMMABLE RELAY AND LEAF DELAY

Board model ALL-ACUL includes a programmable relay (N.O.) with four different configurations. See table below for switch settings. Use the "Leaf Delay" potentiometer to adjust the delay time from 0 to 6 seconds.

- (1) 1 second pulse for every open start cycle
- Typically used for a cycle counter
- (2) "ON" when the gate is in motion
- Typically used for an audible alarm or strobe light to warn when the gate is in motion
- (3) Alarm system output
- Activates the relay when the gate is forced open
- (4) "ON" when gate is not fully closed
- Typically used for an indicator

S1	S2	RELAY FUNCTION
OFF	OFF	ONE SECOND PULSE FOR EVERY OPEN START CYCLE
ON	OFF	ON WHEN GATE IS IN MOTION
OFF	ON	ALARM SYSTEM OUTPUT
ON	ON	ON WHEN GATE IS NOT FULLY CLOSED

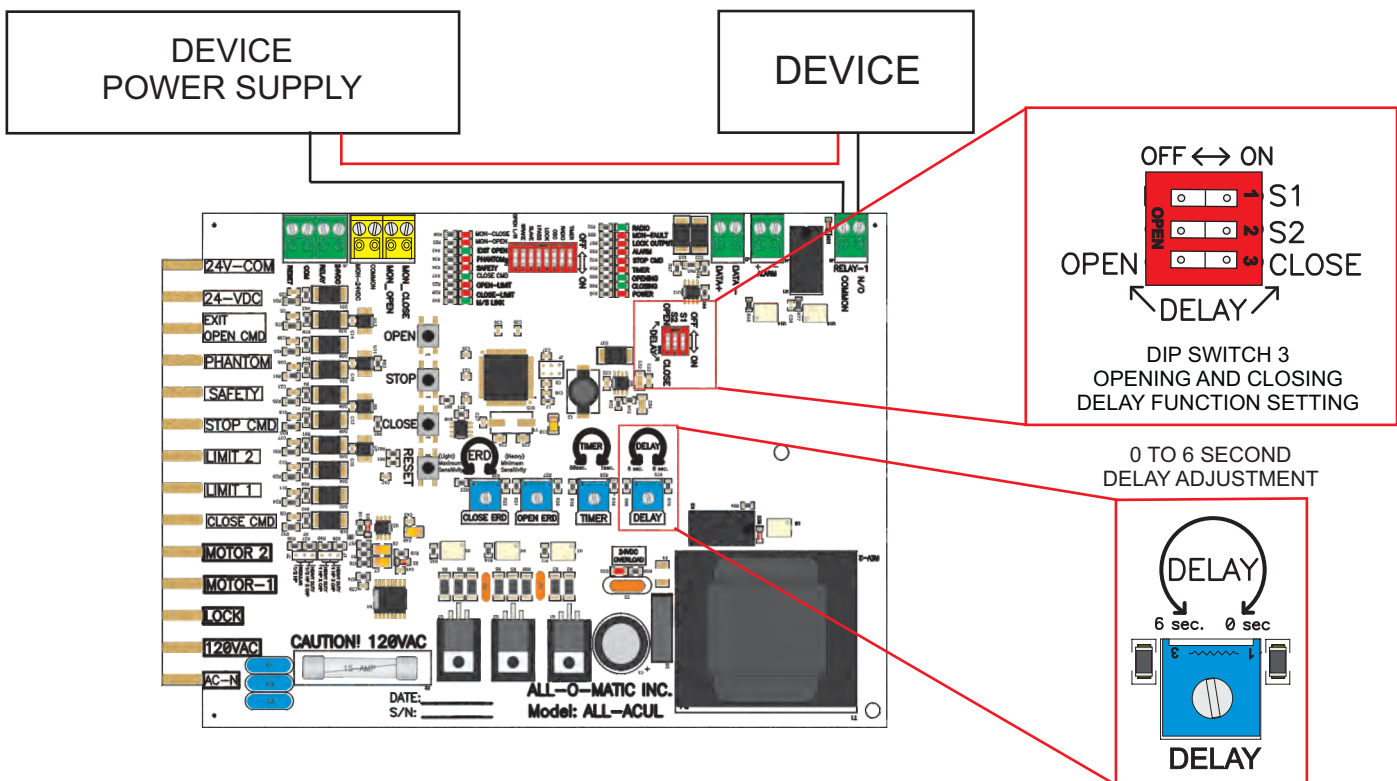

TIMER ADJUSTMENT AND RADIO SETTING

TIMER ON: Automatic timer to close can be set from 1 to 60 seconds

TIMER OFF: Gate operation is "push button to open, push button to close"

RADIO ON: To override the timer and allow the radio receiver to close the gate before the timer



Turn potentiometer counter clockwise for more time



Turn potentiometer counter clockwise for less time

NOTE: If potentiometer is turned all the way counter clockwise, the timer is disabled and the gate WILL NOT close automatically.

TIMER "ON" TO
ACTIVATE THE TIMER

RADIO "ON" = ALLOWS THE
TRANSMITTER TO CLOSE
THE GATE BEFORE THE TIMER

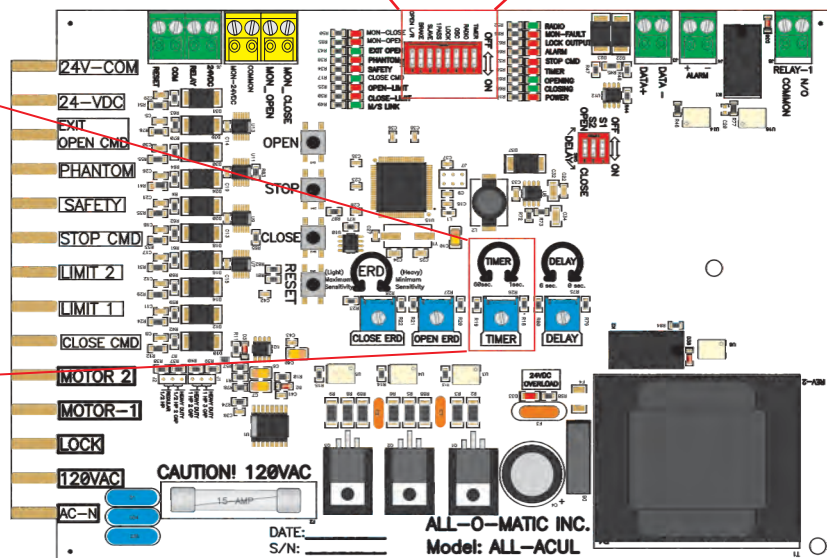
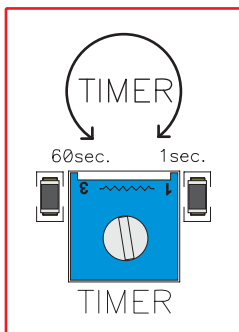
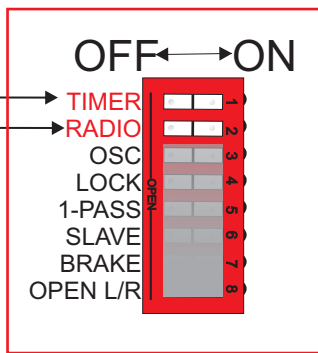

ELECTRONIC REVERSING DEVICE (ERD) ADJUSTMENT

All AC boards are equipped with an Electronic Reversing Device (ERD), which will cause the gate to reverse direction when it comes into contact with an obstruction.

The amount of force required to reverse the gate's direction depends on the ERD sensitivity setting and motor rating. Make sure the ERD jumper is set to the correct pin setting (see chart below).

The ERDs must be adjusted for the operator to provide regular, reliable & safe operations. If the gate reverses direction on its own without hitting an obstruction, the ERD is too sensitive. If the gate does not reverse when it hits an obstruction, the ERD is not sensitive enough.

ERDs must be adjusted by a qualified technician.

The gate operator ERDs shall be tested and adjusted if necessary every six months.

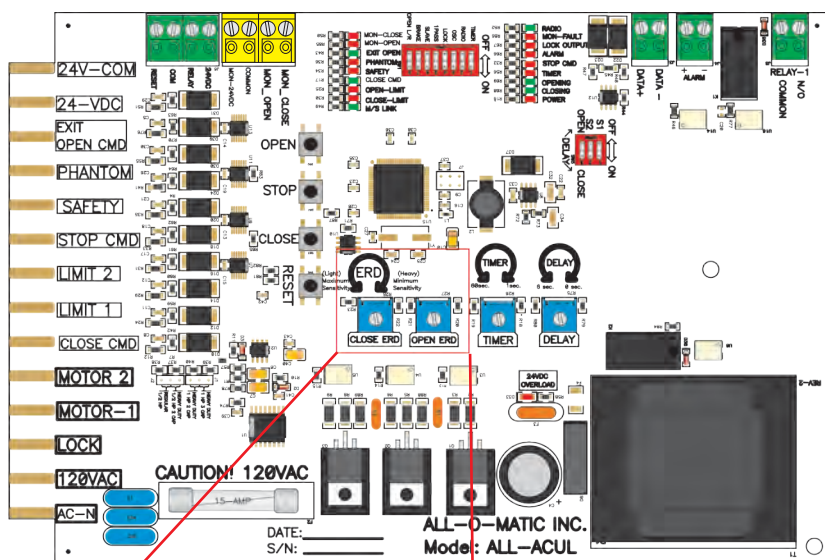

SET THESE PINS ACCORDING TO YOUR OPERATOR MODEL USING THE CHART BELOW:

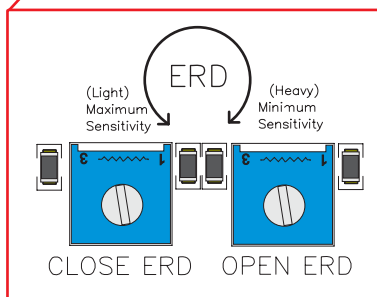
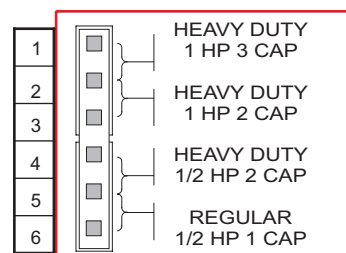

OPEN AND CLOSE ERD SENSITIVITY

MOTOR RATING CHART			
MODEL	HP RATING	# OF CAPS	PIN #
SL-100	1/2	1	5-6
SL-150	1/2	2	4-5
SL-150	1	2	2-3
SL-150	1	3	1-2

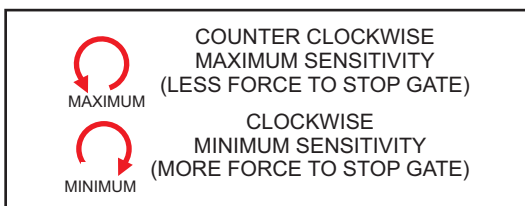

DIP SWITCH FUNCTIONS

TIMER

TIMER switch “ON” activates the automatic close timer.

RADIO

RADIO switch “ON” allows the radio receiver to override the automatic close timer.

OSC

OSC switch “ON” allows the radio receiver to stop and reverse the gate in any direction. During a cycle, the first signal stops the gate. A second signal reverses the gate.

LOCK

LOCK switch “ON” is used when a mag lock is installed. “OFF” is used when a solenoid lock is installed or no lock is installed.

1-PASS

1-PASS switch “ON” allows the gate to open until one vehicle goes over the safety loop. Once the vehicle has cleared the loop, the gate will stop and close. If a second vehicle goes over the loop while the gate is closing, the gate will stop. The vehicle must get off of the loop before the gate continues to close, forcing the second vehicle to present valid credentials. This is a true one pass, anti-tailgating feature to be used with safety loops.

SLAVE

This feature is used in dual gate applications. The **SLAVE** switch will be “ON” only on the slave operator. All other dip switches will be “off”. **SLAVE** switch will be “OFF” on the master operator. Set desired dip switch settings on the master operator only.

BRAKE

BRAKE switch “ON” assists in stopping the gate at the moment of contact between the limit nut and limit switch. This function should only be used on uphill or downhill applications. A 20-amp fuse should be used when this switch is on.

OPEN L/R

OPEN L/R switch “ON” is used for right hand opening of the gate. The “OFF” position is used for left hand opening of the gate.

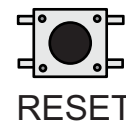
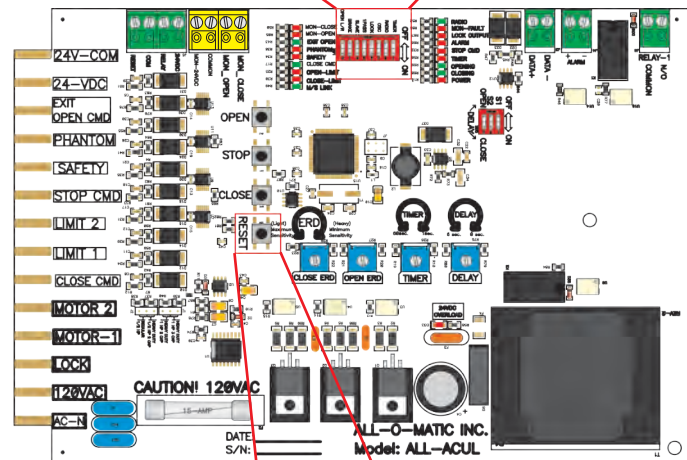
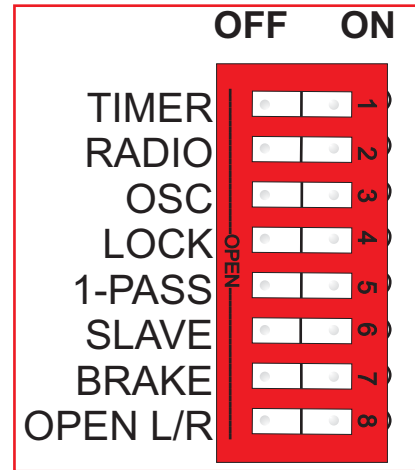

NOTE: IF ANY CHANGES ARE MADE TO THE DIPSWITCHES WITH THE POWER ON, PRESS THE **MAIN RESET** BUTTON TO RECOGNIZE THE CHANGE.

ACCESSORY CONNECTIONS

The circuit board has a 24 VDC terminal that provides up to 700 mAmps to power accessories such as loop detectors, keypads, etc. If the total current draw of your accessories exceeds the 700 mAmps, a separate power supply (transformer) is required.

When installing a safety loop detector or pedestrian/stop switch, make sure to REMOVE the black jumper between the 24V-COM and SAFETY and/or STOP_CMD terminals.

NO Contacts	NC Contacts
Exit Loop Detector	Safety Loop Detector
Keypad	Photo Eye
Telephone System	Ped or Stop Switch
Push Button	
Card Reader	

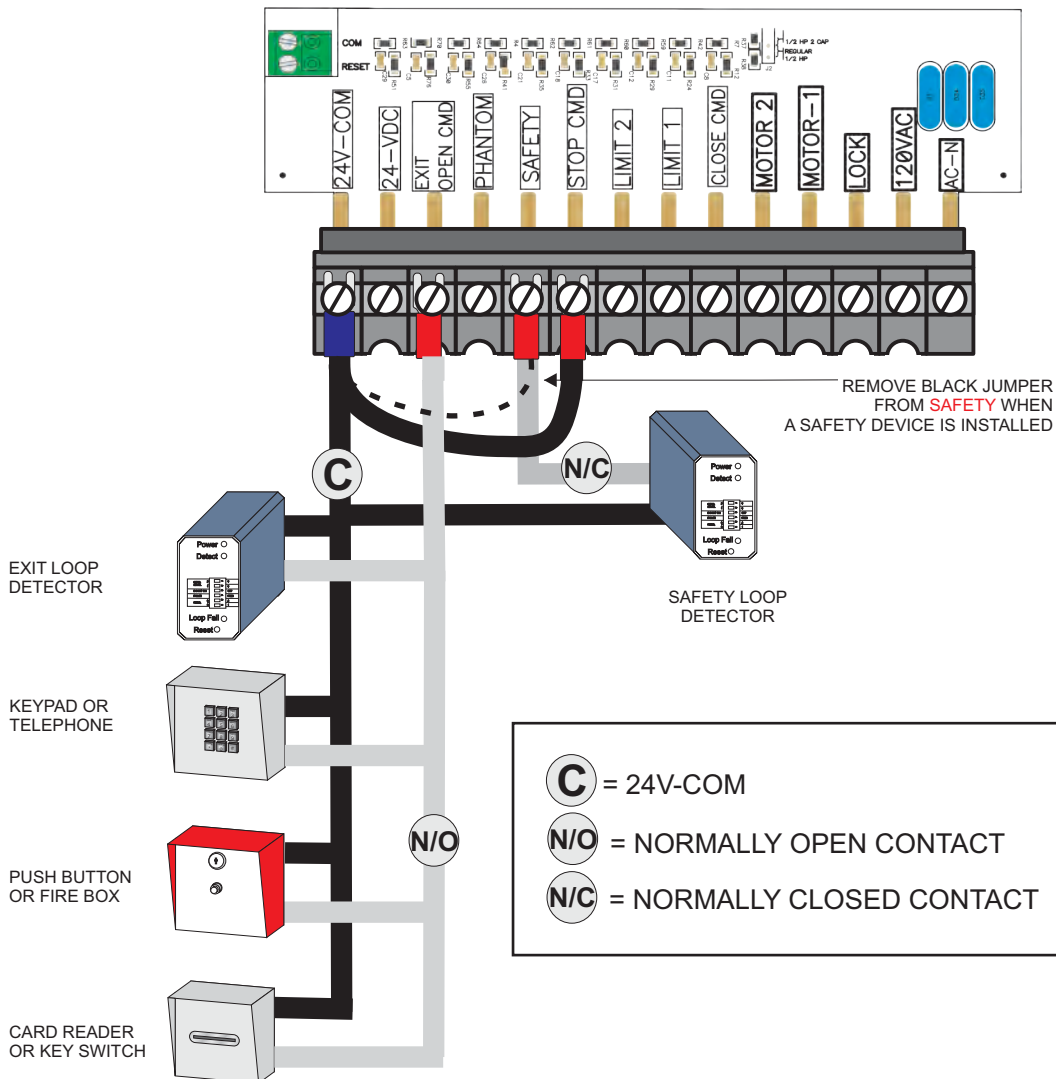

MONITORED ENTRAPMENT PROTECTION DEVICE CONNECTION

- There are 2 types of sensors that can be connected to the gate operator for UL 325 monitored entrapment compliance: non-contact sensors (photo eye) and contact sensors (edge sensors).
- Monitored entrapment protection devices use 4 wires to connect to the board. From the device, connect the **RELAY COMMON** to the board **COMMON** and the **NORMALLY CLOSED** relay contact to the assigned **MON_OPEN** or **MON_CLOSE** input. Connect the power wires to the **COMMON** and **MON-24VDC**.
- **IMPORTANT:** You must use the MON-24VDC to properly monitor entrapment protection devices. Do not use the 24 VDC terminal on the board's terminal strip. To turn this voltage for initial setup, press the reset button on the board.
- **NOTE:** The power to the **MON-12/24VDC** terminal will be off when the gate is at rest (not moving). It will be normal to see the **MON_OPEN** and **MON_CLOSE** LEDs when the gate is closed. If the auto close timer is **OFF** it will do the same when the gate is at rest in the open position. If no devices are connected, both of these lights will stay ON.
- Please refer to the device manufacturer's wiring instructions for details, making sure to follow the normally closed wiring directions. Some devices may work on monitoring interfaces other than normally closed.
- Should there be a need for more than 1 entrapment protection device for each direction, use a multi-input module from Miller Edge (model: MIM-62).

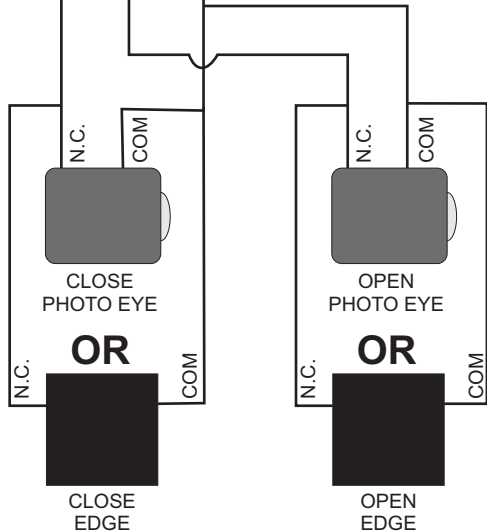
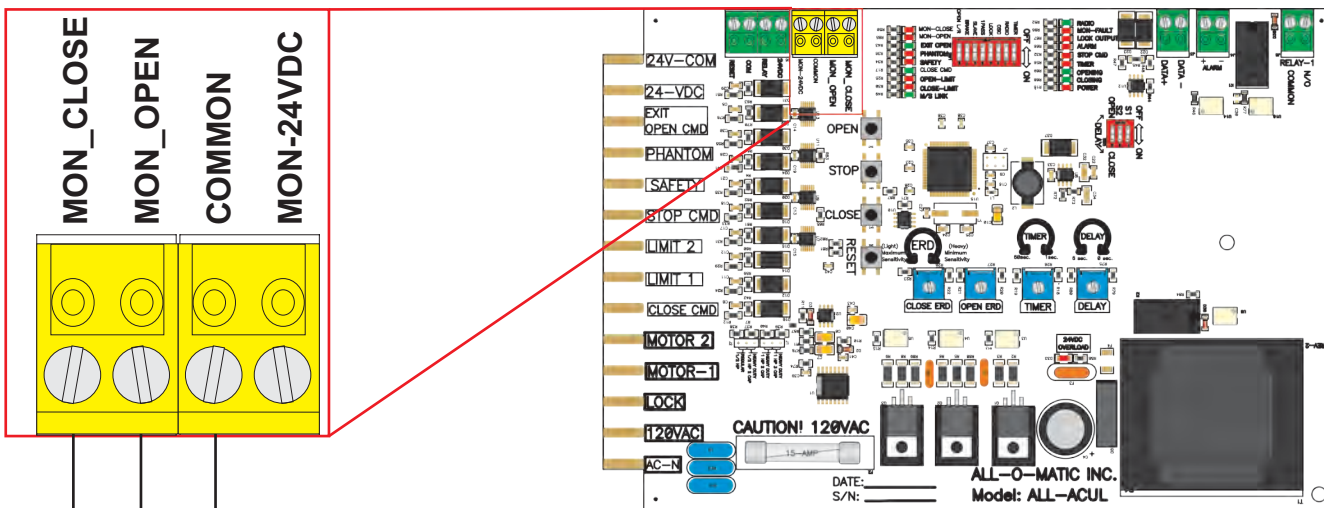

MON_CLOSE (LED will indicate when an obstruction is detected or device is not present)
 This input is only for the monitored entrapment protection device for the close direction. When the gate is closing, it will open to the full open position if an obstruction is sensed and resets the automatic close timer. This input does nothing in the opening direction. If a device is not connected or it senses a fault (MON_FAULT LED will turn on), the operator will only work with a constant pressure actuated switch.

MON_OPEN (LED will indicate when an obstruction is detected or device is not present)
 This input is only for the monitored entrapment protection device for the open direction. When the gate is opening, it will reverse for 2 seconds and stop if it senses an obstruction. This input does nothing in the closing direction. Upon power up, if a device is not detected, the operator will assume that one is not required for the opening direction. If a device is connected and the board detects a fault (MON_FAULT LED will turn on), the operator will only work with a constant pressure actuated switch.

MONITORED ENTRAPMENT PROTECTION DEVICE CONNECTION

ENFORCER E-960-D90GQ/ E-931-S33RRGQ / E-931-S50RRGQ	
CONTACT	BOARD TERMINAL
N.C.	MON_CLOSE OR MON_OPEN
COM	COMMON
12-30 VDC/AC	COMMON
12-30 VDC/AC	MON_12/24VDC

ENFORCER E-936-S45RRGQ	
WIRE	BOARD TERMINAL
BLACK	MON_CLOSE OR MON_OPEN
WHITE	COMMON
BLUE	COMMON
BROWN	MON_12/24VDC

ALLEN BRADLEY GRU-24	
WIRE	BOARD TERMINAL
BLACK	MON_CLOSE OR MON_OPEN
ORANGE	COMMON
BLUE	COMMON
BROWN	MON_12/24VDC

OMRON E3K-R10K4-NR		
SWITCH	CONTACT	BOARD TERMINAL
LIGHT ON	N.O.2	MON_CLOSE OR MON_OPEN
	C.2	COMMON
	24 TO 240 VAC	COMMON
	24 TO 240 VAC	MON_12/24VDC

EMX IRB-MON		
SWITCH	CONTACT	BOARD TERMINAL
SW1 - OFF	N.C.	MON_CLOSE OR MON_OPEN
SW2 - OFF	COM	COMMON
SW3 - ON	POWER/ VRX	COMMON
SW4 - OFF	POWER/ VRX	MON_12/24VDC

EMX IRB-325	
CONTACT	BOARD TERMINAL
N.C.	MON_CLOSE OR MON_OPEN
COM	COMMON
POWER	COMMON
POWER	MON_12/24VDC

EMX NIR-50-325	
WIRE	BOARD TERMINAL
BLACK	MON_CLOSE OR MON_OPEN
WHITE	COMMON
BLUE	COMMON
BROWN	MON_12/24VDC

EMX IRB-RET		
SWITCH	CONTACT	BOARD TERMINAL
SW1 - OFF	N.C.	MON_CLOSE OR MON_OPEN
SW2 - OFF	COM	COMMON
SW3 - OFF	POWER/ VRX	COMMON
SW4 - ON	POWER/ VRX	MON_12/24VDC

TRANSMITTER SOLUTIONS R50R-UL/R32P-UL/SR33HD/SR66HD	
CONTACT	BOARD TERMINAL
N.C. (3)	MON_CLOSE OR MON_OPEN
COM (5)	COMMON
NON POLARITY (1)	COMMON
12-30 VDC/AC (2)	MON_12/24VDC

TRANSMITTER SOLUTIONS iGAZE RE KIT		
SWITCH	CONTACT	BOARD TERMINAL
ALL OFF	N.C.1	MON_CLOSE OR MON_OPEN
	COM	COMMON
	(-) 12/24 VDC	COMMON
	(+) 12/24 VDC	MON_12/24VDC

EMX WEL-200	
CONTACT	BOARD TERMINAL
RELAY CLOSE (NC) RELAY OPEN (NC)	MON_CLOSE MON_OPEN
RELAY CLOSE (COM) RELAY OPEN (COM)	COMMON COMMON
POWER	COMMON
POWER	MON_12/24VDC

MILLER EDGE R BAND 6 WIRES FOR 1 EDGE - 8 WIRES FOR 2 EDGES		
SWITCH	CONTACT	BOARD TERMINAL
SW 1 - ON	N/C N/C	MON_CLOSE MON_OPEN
SW 2 - ON	COM COM	COMMON COMMON
SW 3 - ON	COM A.TEST	COMMON MON_12/24VDC
SW 4 - ON	12/24 (+) AC/DC	24-VDC GROUND

MON_CLOSE = PROTECTS ACROSS THE DRIVEWAY/CLOSING DIRECTION
 MON_OPEN = PROTECTS THE REAR SLIDE / OPENING DIRECTION

THREE BUTTON STATION CONNECTION

- A three button station and reset push button are integrated on the board to make limit and ERD adjustments easier.
- An external three button station may also be installed. See diagram below for wiring instructions,
- **NOTE: STOP CMD jumper must be removed if a three button station is installed.**

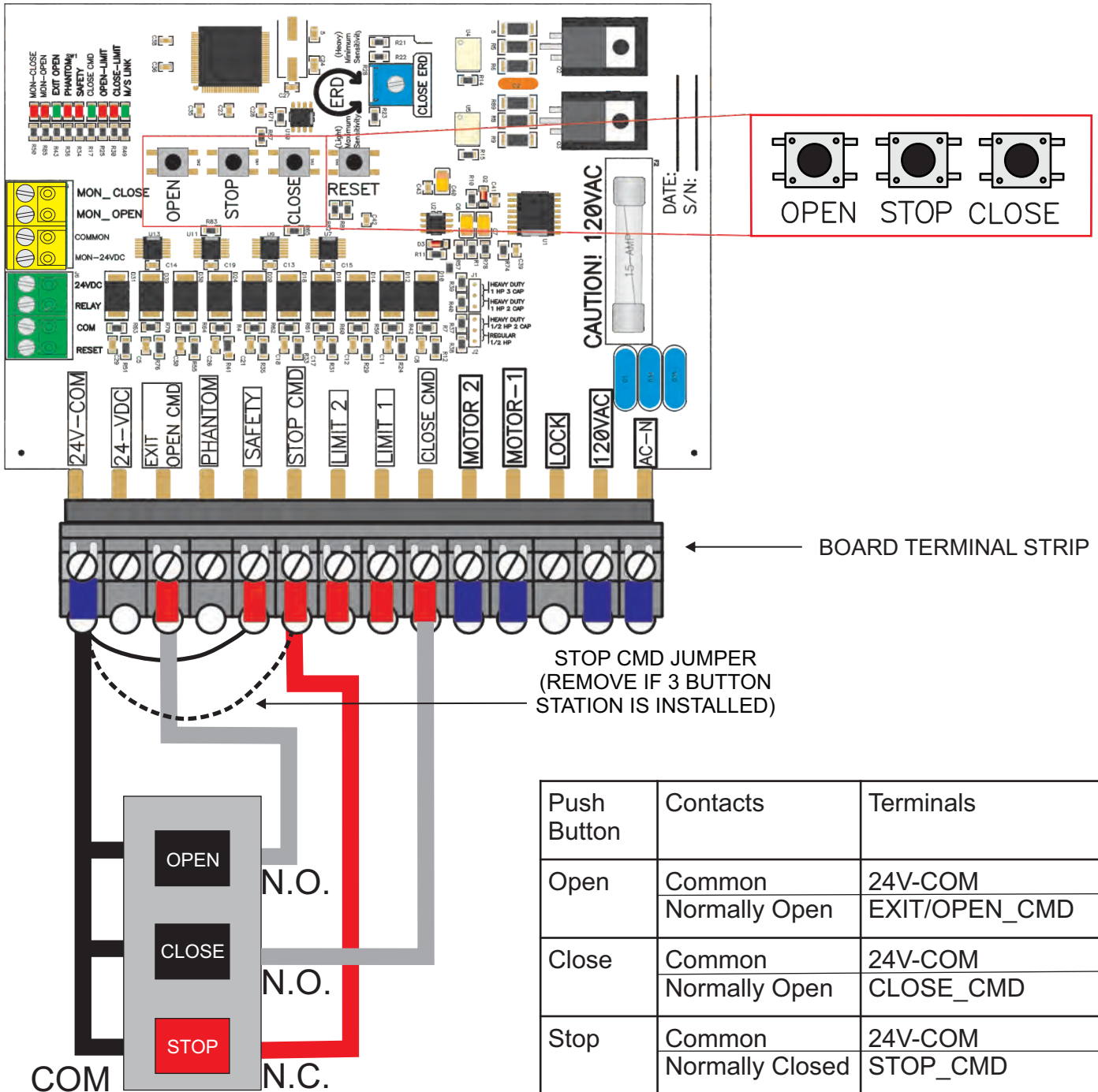

RADIO RECEIVER CONNECTION

There are two types of receivers: 3-wire and 4-wire:

3 wire receivers can mount on the radio receiver terminal strip located outside of the control box.

For 4 wire receivers, connect the 2 gray wires to terminals 1 and 2 on the receiver terminal strip located outside of the control box. Connect the black wire to the 24V-COM and the red wire to the 24 VDC on the board terminal strip as shown below.

RADIO dip switch ON allows the radio receiver to override the automatic close timer.

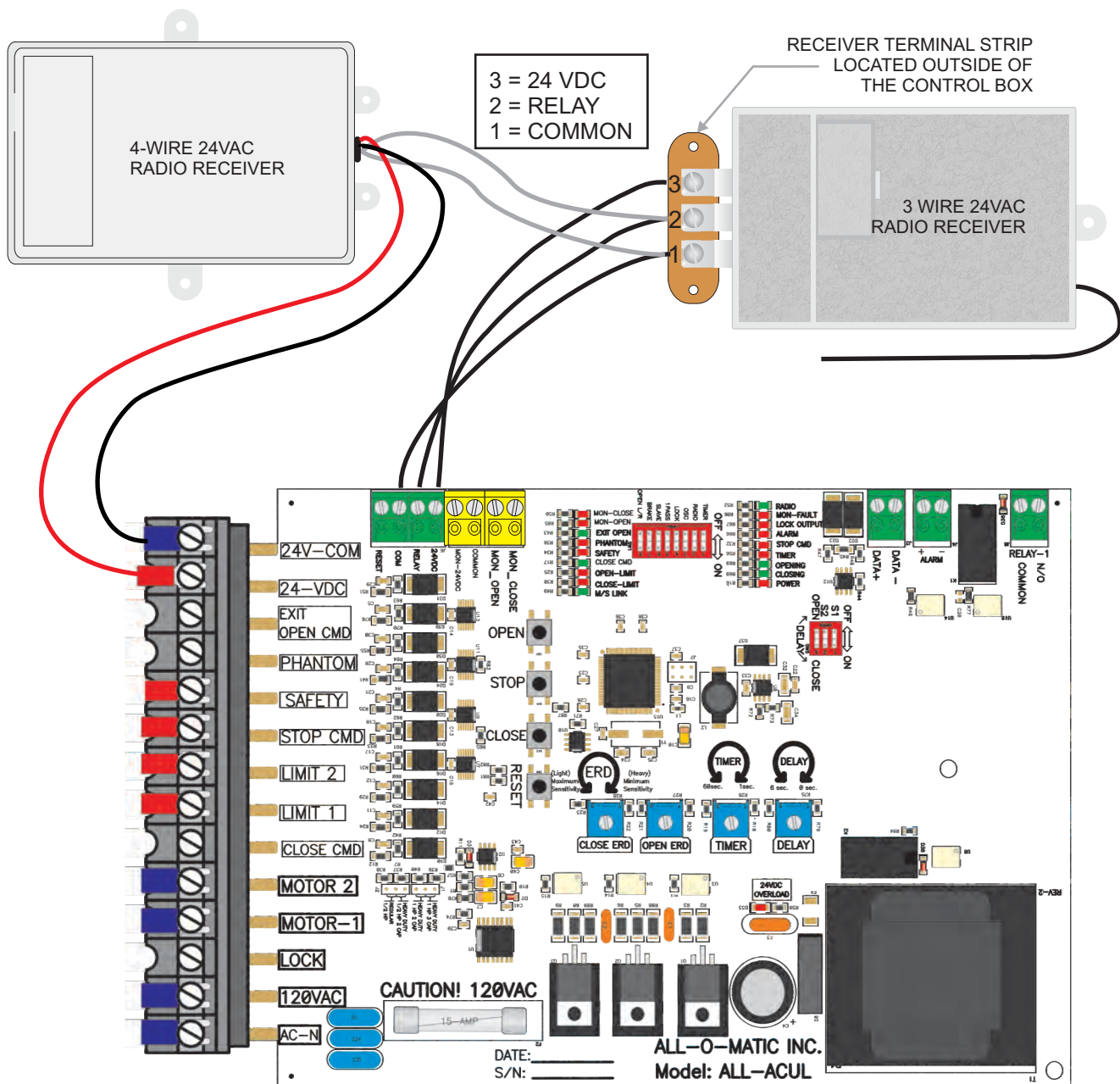

BREATHER CAP PIN

NOTE: After operator installation, remove the breather cap pin from the gear box for proper installation.

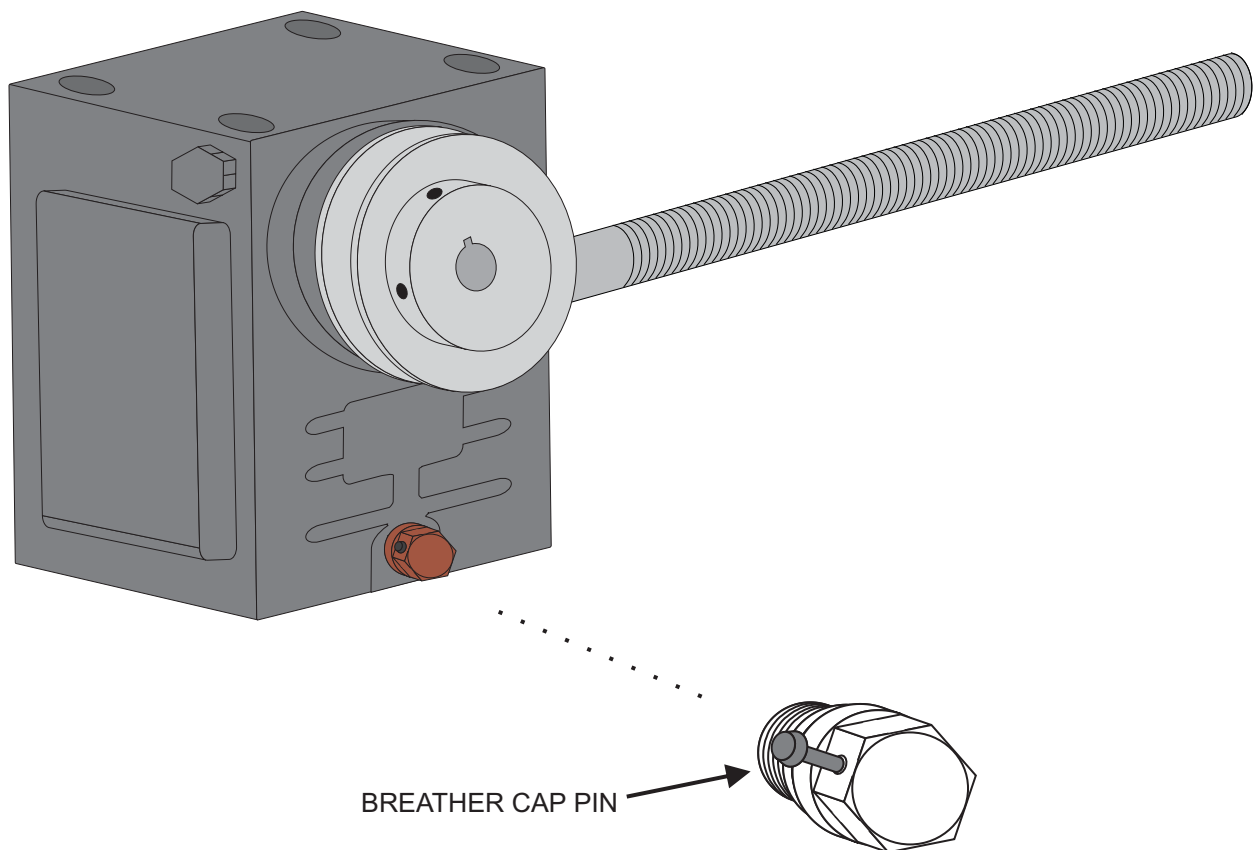

EMERGENCY RELEASE INSTRUCTIONS

Make sure the gate is in the full open position to prevent the gate from coming down if it is not well balanced.

To manually release the gate from the operator:

- Move the locking latch to the side
- Pull the release ring downward
- Slide the latch with the slit backward to disengage it from the lock pin.

NOTE: To avoid serious injury, only disengage the gate when it is clear of people and obstructions.

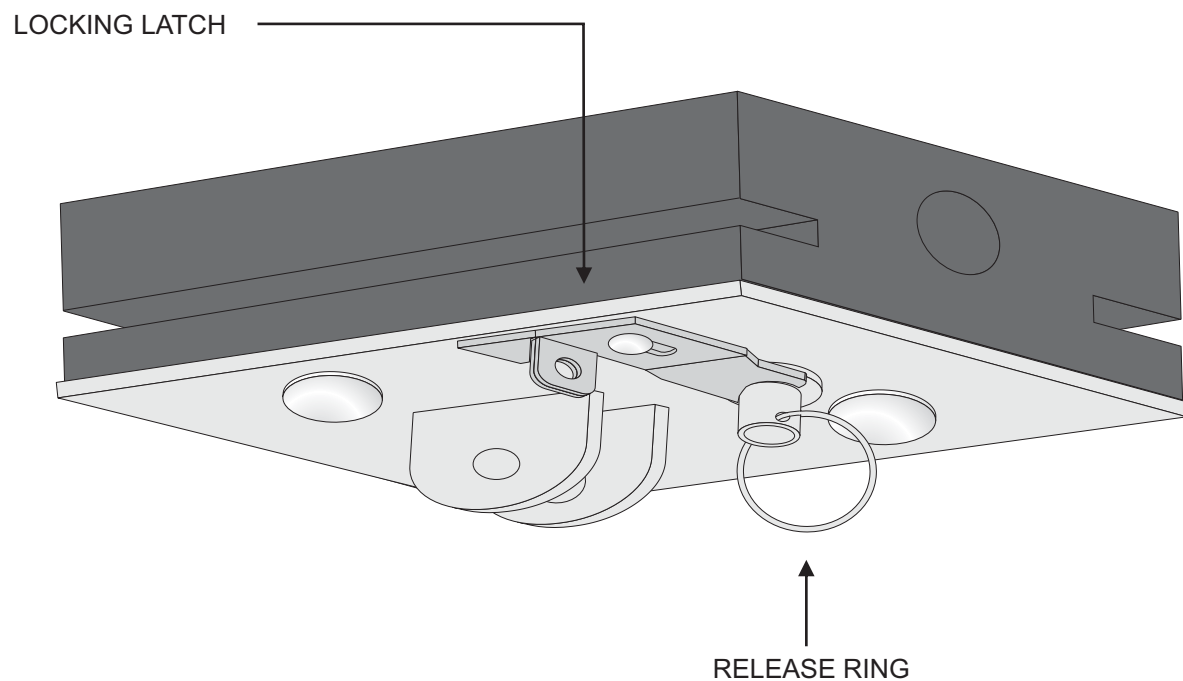

OPERATOR CURRENT DRAW AND VOLTAGE DROP CHART

AC GATE OPERATORS	CURRENT DRAW @ 115VAC
SL-100AC(FP)	4.7 AMPS
SL-150AC – ½ HP	6.2 AMPS
SL-150AC – 1 HP	8.4 AMPS
SW-300AC	4.7 AMPS
SW-350AC – ½ HP	4.7 AMPS
SW-350 AC – 1 HP	8.4 AMPS
OH-200AC	4.7 AMPS

Max Wire Feet @ 120 Volts, 1 Phase, 2% Max Voltage Drop

Amps	Volt- Amps	#14	#12	#10	#8	#6
1	120	450	700	1100	1800	2800
5	600	90	140	225	360	575
10	1200	45	70	115	180	285
15	1800	30	47	75	120	190
20	2400	œ	36	57	90	140
25	3000	œ	œ	45	72	115
Amps	Volt- Amps	#4	#2	1/0	2/0	3/0
1	120	4500	7000	œ	œ	œ
5	600	910	1400	2250	2800	œ
10	1200	455	705	1100	1400	1800
15	1800	305	485	770	965	1200
20	2400	230	365	575	725	900
25	3000	180	290	460	580	720

Max Wire Feet @ 240 Volts, 1 Phase, 2% Max Voltage Drop

Amps	Volt- Amps	#14	#12	#10	#8	#6
1	240	900	1400	2200	3600	5600
5	1200	180	285	455	720	1020
10	2400	90	140	225	360	525
15	3600	60	95	150	240	350
20	4800	œ	70	110	180	265
25	6000	œ	œ	90	144	210
Amps	Volt- Amps	#4	#2	1/0	2/0	3/0
1	240	9000	œ	œ	œ	œ
5	1200	1750	2800	4500	5600	7000
10	2400	910	1400	2200	2800	3600
15	3600	605	965	1500	1900	2400
20	4800	455	725	1100	1400	1800
25	6000	365	580	920	1100	1440

TECHNICAL TIPS

How to tell what mode your board is in. The firmware must match the entrapment protection device wiring or you will get a "MON-FAULT" on the circuit board.

- The number of times the "MON-FAULT" light blinks when you press and release "RESET" on the circuit board:

- 1 blink = Pre-UL (monitored entrapment device is NOT required)
- 2 blinks = UL-2016 (1 monitored entrapment protection device for the close direction is required)
- 3 blinks = UL-2018 (1 monitored entrapment protection device for each the open and close directions are required)

The gate starts running on its own (without a command) when the power is turned on and ignores the limit switch

- There is a bad open/close triac (component) on the board. Please send the board in for repair.
- If the power is turned on and the motor starts humming and the gate does not move, both the open and close triacs (component) are bad.

The 24VDC overload light is on

- The overload light indicates that a device connected to the gate operator is shorted. Remove all wires connected to "24VDC" and check if the overload light goes off. If it does, connect the wires in one by one to determine which device is shorted. If the light does not go off, remove the green radio and monitored entrapment device terminals to see if the light turns off.

The ERD potentiometer is all the way clockwise but keeps triggering

- Check your gate and hardware. You should be able to manually open and close the gate easily
- Make sure your ERD jumper is on the correct setting. Find the ERD jumper above "MOTOR 2" on the circuit board. Move the jumper up one pin and re-adjust the ERD potentiometers if needed.

Technical Support

- Technical Support is available in English and Spanish, Monday-Friday from 7:00 am to 3:30 pm PST
- Call us at (818) 787-1988

Advance Replacement/ Repair and Return Policy

- We advance replace items within the first (2) years of the operator date. In order to get an advance replacement, you must call our tech support and troubleshoot from the job site. If the item is determined to be defective, we will issue the technician a RMA number to give to the distributor. The distributor will send us a PO for the advance replacement item. Please note that any warranty item over (2) years will be repair and return only.
- We repair defective boards (including boards out of warranty) at no charge, provided that the board components are still available (applicable to boards over (15) years old) and that the board was not damaged by a power surge or has evidence of water damage. You can send the board in directly to us or send it to us through your distributor. We do our best to get the boards out 1-2 days after we receive it.

WARRANTY AND RECORD

MANUFACTURER'S LIMITED WARRANTY

ALL-O-MATIC INC warrants the following gate operators (SL-100 AC[FP] and SL-150AC) for a period of five (5) years in commercial installations and for a period of seven (7) years in residential installations. The above operators, within their warranty period, are to be free from defects in circuitry, motor, gearbox and workmanship. This warranty begins from the date of purchase to the original owner. Warrantor will repair or, at its option, replace any device which it finds to require service. This device must be sent to the warrantor at the consumer's expense to:

**ALL-O-MATIC INC.
7820 GLORIA AVE.
VAN NUYS, CA 91406**

The warrantor will return the repaired or replaced unit to the customer at the consumer's expense. Labor charges for dealer service or replacement are the responsibility of the owner. These warranties are in lieu of all other warranties either expressed or implied, and ALL-O-MATIC INC shall not be liable for consequential damage. All implied warranties of merchantability and or fitness for a particular purpose are hereby disclaimed and excluded. This limitation is not valid in jurisdictions which do not allow limitation of incidental or consequential damages or limitation of warranty periods. In order to obtain this policy, please complete the registration card and send it by mail within 30 days of purchasing from ALL-O-MATIC INC. or your installer. If the product is not registered, only a one year warranty on all parts will be provided.

CUSTOMER RECORD

Customer Name _____

Address _____

Purchased from (Installation Co.) _____

Date _____

Model Number _____

Serial Number _____ - _____