



**DC
SLIDE
MANUAL**

ALL-O-MATIC®

SL-45DC | SL-90DCFP | SL-100DC | SL-150DC

DC SLIDE GATE OPERATORS MANUAL

UL325
COMPLIANT

UL991
COMPLIANT

CANADA
CSA C22.2
COMPLIANT



ALL-O-MATIC
MANUAL

Rev. UL2 10/17

TABLE OF CONTENTS

SAFETY AND INTRODUCTION

Safety Instructions	1-2
UL 325 Class Types	3
Operator Specifications	4-5

INSTALLATION

SL-45 DC Concrete Pad Installation	6
SL-90 DC Concrete Pad Installation	7
SL-100 DC [FP] Concrete Pad Installation	8
SL-150 DC Concrete Pad Installation	9
Front and Rear Mount Installation	10-12
Entrapment Protection Installation	13
Loop Layout	14
Electrical Connection	15
Gate Travel Adjustment	16
SL-150 DC Clutch Adjustment	17

BOARD FEATURES

Gate Opening Direction Setting	18
Programmable Relay and Leaf Delay	19
Electronic Reversing Device (ERD) Adjustment	20
Timer Adjustment and Radio Setting	21
Dip Switch Functions	22
LED Diagnostics	23

ACCESSORY INSTALLATION

Accessory Connections	24
Monitored Entrapment Protection Device Connections	25-27
Plug-in Detector Installation	28
Three Button Station Connection	29
Master/Slave Connection	30
Magnetic/Solenoid Lock Connection	31
Radio Receiver Connection	32

SOLAR INSTALLATION

Solar Panel Connection	33
External Solar System Installation	34

EMERGENCY RELEASE INSTRUCTIONS

Emergency Release for SL-45 DC	35
Emergency Release for SL-90 DC, SL-100 DCFP, and SL-150 DC	36

ACCESSORIES AND PARTS BREAKDOWN

Pad Lock Tabs	37
SL-45 DC Blowout Drawing	Check Website
SL-90 DC Blowout Drawing	Check Website
SL-100 DC[FP] Blowout Drawing	Check Website
SL-150 DC Blowout Drawing	Check Website

WARRANTY AND CUSTOMER RECORD	38
---	-----------

IMPORTANT SAFETY INSTRUCTIONS

WARNING

TO REDUCE THE RISK OF **INJURY**:

READ AND FOLLOW ALL INSTALLATION INSTRUCTIONS. DO NOT START INSTALLATION UNTIL YOU HAVE READ AND UNDERSTAND THESE DIRECTIONS. IF THERE IS SOMETHING YOU DO NOT UNDERSTAND, PLEASE CALL US.

NEVER let children operate or play with gate controls.

Locate the control station and make sure it is (a) within sight of the gate and (b) at a minimum height of 5 feet so small children cannot reach it.

Install the enclosed entrapment warning signs next to the control station and in a prominent location.

For operators equipped with a manual release, instruct the end user on the correct operation of the manual release. Use the manual release only when the gate is not moving. It is advised that the power be turned off.

Always keep people and objects away from the gate. No one should cross the path of a moving gate.

The gate operator must be tested monthly. The gate must reverse on contact with a rigid object, or stop when an object activates the non-contact sensor(s). Always re-test the operator after adjusting the limits and/or force. Failure to adjust and re-test the gate operator properly may cause severe injury or death.

Keep gate(s) properly maintained. Have a qualified service technician make repairs to gate hardware and make proper adjustments to gate operator.

This gate entrance/exit is for vehicles only. Pedestrians must use a separate entrance.

There is nothing on a gate operator that is easily repaired or adjusted without a great deal of experience. Call a qualified gate service technician who knows your gate operator.

SAVE THESE INSTRUCTIONS

IMPORTANT SAFETY INSTRUCTIONS (CONTINUED)

INSTALL THE GATE OPERATOR ONLY WHEN YOU HAVE READ THE FOLLOWING

BEFORE GATE OPERATOR INSTALLATION

- Confirm that the gate operator being installed is appropriate for the application.
- Confirm that the gate is designed and built according to the current published industry standards.
- Confirm that all appropriate safety features and safety accessory devices are being installed, including all entrapment protection devices.
- Make sure that the gate opens and closes freely (by hand) before installing the operator.
- Repair or replace worn or damaged gate hardware before installing the gate operator.
- Eliminate all gaps in the sliding gate below a 6 foot height that permits a 2 1/4" sphere to pass through any location. This includes the area of the adjacent fence covered when the gate is in the open position
- Eliminate all gaps in a swing gate below a 4 foot height that permits a 4" sphere to pass through any location. This includes the hinge area of the gate.
- Install a proper electrical ground to the gate operator.
- Controls intended for user activation must be located at least 6 feet away from any moving part of the gate, and where the user is prevented from reaching over, under, around, or through the gate to operate the controls.
- Outdoor or easily accessible controls shall have a security feature to prevent unauthorized use.
- The stop and/or reset button must be located in the line of sight of the gate. Activation of the operator reset control shall not cause the operator to move.
- Install a minimum of 2 warning signs, one on each side of the gate where they are easily visible.
- Take pictures of the installation.
- Test all safety features for proper function before placing the automatic vehicular gate in operation.

GATE OPERATOR INSTALLATION

- Operator must be disconnected from the power source before attempting any installation of accessories.
- Install gate operator according to the installation instructions in this manual.
- Adjust the operator clutch or load sensing device to the minimum force setting that will allow for reliable gate operation.
- Install the operator inside the fence line. Do not install the operator on the public side of the fence line.

MAINTENANCE

- Train owners/users on the basic functions and safety features of the gate system, including how to turn off the power and operate the manual disconnect feature.
- Leave safety instructions, product literature, installation manual, and maintenance manual with the owner or end user.
- Explain to the owner or end user the importance of routine service and operator testing on a monthly basis.

UL 325 CLASS TYPES AND OBSTRUCTION SENSING SYSTEMS

Each class must have (2) monitored entrapment protection devices in each entrapment zone to sense and react to obstructions within 2 seconds.

All-O-Matic's gate operators conform to the most rigid Class One.

UL 325 CLASS TYPES

CLASS ONE: RESIDENTIAL

- A vehicular gate operator intended for use in garages or parking areas associated with a residence of one to four single families.

CLASS TWO: COMMERCIAL OR GENERAL PUBLIC ACCESS

- A vehicular gate operator intended for use at a commercial location or building, such as a multi-family housing unit (five or more single family units), hotel, garages, retail stores, or other buildings accessible by or servicing the general public.

CLASS THREE: INDUSTRIAL OR LIMITED ACCESS

- A vehicular gate operator intended for use at an industrial location or building, such as a factory, loading dock area, or other locations not accessible by or intended to service the general public.

CLASS FOUR: RESTRICTED ACCESS

- A vehicular gate operator intended for use at a guarded industrial location or building, such as airport security areas or other restricted access locations not servicing the general public and where unauthorized access is prevented via supervision by security personnel.

THE SIX TYPES OF OBSTRUCTION SENSING SYSTEMS

TYPE A:

- Inherent entrapment protection system. This system must sense and initiate the reverse of the gate within 2 seconds of contact with a solid object.

TYPE B1:

- Non-contact sensor (photoelectric sensor or equivalent). This system shall, upon sensing an obstruction in the direction of the gate travel, reverse the gate within a maximum of 2 seconds.

TYPE B2:

- Contact sensor (edge device or equivalent). This system shall, upon sensing an obstruction in the direction of the gate travel, initiate the reversal of the gate within a maximum of 2 seconds.

TYPE C:

- Inherent force limiting, inherent adjustable clutch, or pressure relief valve.

TYPE D:

- Actuating device requiring continuous pressure to maintain opening or closing motion of the gate.

OPERATOR SPECIFICATIONS

	SL-45 DC	SL-90 DC
Max Gate Weight	800 lbs.	1,600 lbs.
Max Gate Length	30 feet	50 feet
Warranty	5 year residential	7 year residential 5 year commercial
Motor	24 VDC brushless with planetary gearbox	24 VDC brushless 1/2 HP motor
Gate Speed	12" per second	12" per second
Power Options	115 VAC 50/60Hz single phase - 2 amps 230 VAC 50/60Hz single phase - 1 amp 24 VDC solar panel up to 80 watts	115 VAC 50/60Hz single phase - 4 amps 230 VAC 50/60Hz single phase - 2 amps 24 VDC solar panel up to 80 watts
Duty Cycle	Continuous	Continuous
Temperature Range	-40° to 160°	-40° to 160°
Gearbox Ratio	Approx. 29:1	20:1 with internal disconnect
Width X Length X Height	11" W X 14.5" L X 15.5" H	15.5" W X 18.5" L X 16" H
Shipping Weight	60 lbs.	95 lbs.
Emergency Release	Push open in the event of a power failure	Mechanical foot pedal release
Belt Size	N/A	4L-230 (AX21)
Main Sprocket Size	41B15X5/8	41B22X7/8
Chain Size	41NP (20' included)	41NP (20' included)
Gearbox Sprocket	N/A	N/A
Limit Shaft Sprocket	41B10X5/8"	41B15X5/8
Breaker Requirement	20 amp dedicated	20 amp dedicated
Gearbox Pulley	N/A	2 1/2" with 5/8" bore
Motor Pulley	N/A	2" with 5/8" bore
UL Classes	I & II	I, II, III & IV

OPERATOR SPECIFICATIONS (CONTINUED)

	SL-100 DCFP	SL-150 DC
Max Gate Weight	2,000 lbs.	1/2 HP: 3,000 lbs. 1 HP: 4,000 lbs.
Max Gate Length	50 feet	60 feet
Warranty	7 year residential 5 year commercial	7 year residential 5 year commercial
Motor	24 VDC brushless 1/2 HP motor	24 VDC brushless 1/2 and 1 HP motor
Gate Speed	12" per second	12" per second
Power Options	115 VAC, 50/60Hz single phase - 6 amps 230 VAC, 50/60Hz single phase - 3 amps 24 VDC solar panel up to 80 watts	115/230 VAC, 50/60Hz single phase 1/2 HP: 6/3.5 amps, 1 HP: 8/4.5 amps 24 VDC solar panel up to 80 watts
Duty Cycle	Continuous	Continuous
Temperature Range	-40° to 160°	-40° to 160°
Gearbox Ratio	20:1 with internal disconnect	30:1 with internal clutch
Width X Length X Height	12" W X 17.5" L X 23.5" H	15" W X 19.5" L X 25" H
Shipping Weight	130 lbs.	150 lbs.
Emergency Release	Mechanical foot pedal release	Mechanical foot pedal release
Belt Size	4L-260 (AX24)	N/A
Main Sprocket Size	41B22X7/8	40B22X1
Chain Size	41NP (20' included)	40NP (20' included)
Gearbox Sprocket	N/A	40B22X1
Limit Shaft Sprocket	41B15X5/8	41B10X5/8
Breaker Requirement	20 amp dedicated	20 amp dedicated
Gearbox Pulley	2 1/2" with 5/8" bore	N/A
Motor Pulley	2" with 5/8" bore	N/A
UL Classes	I, II, III & IV	I, II, III & IV

SL-45 DC CONCRETE PAD

TOP VIEW

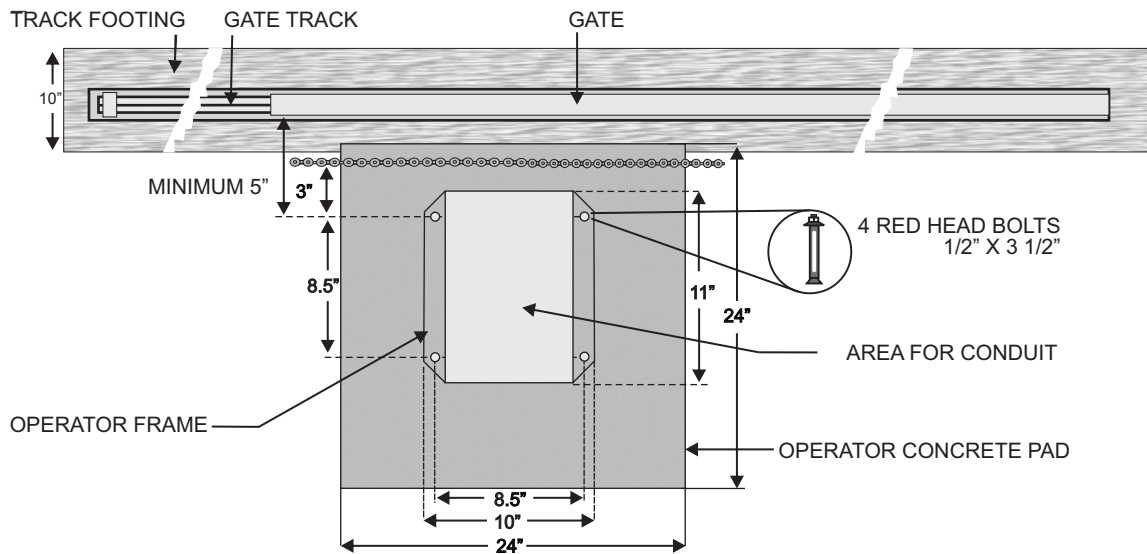

FRONT VIEW

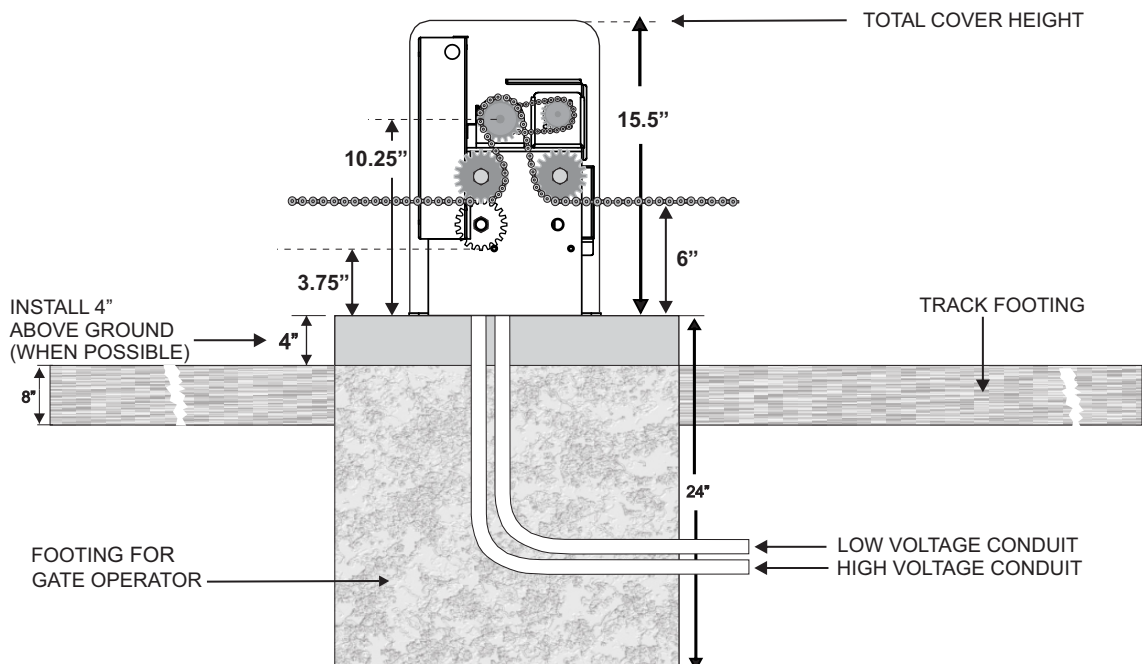

SL-90 DC CONCRETE PAD

TOP VIEW

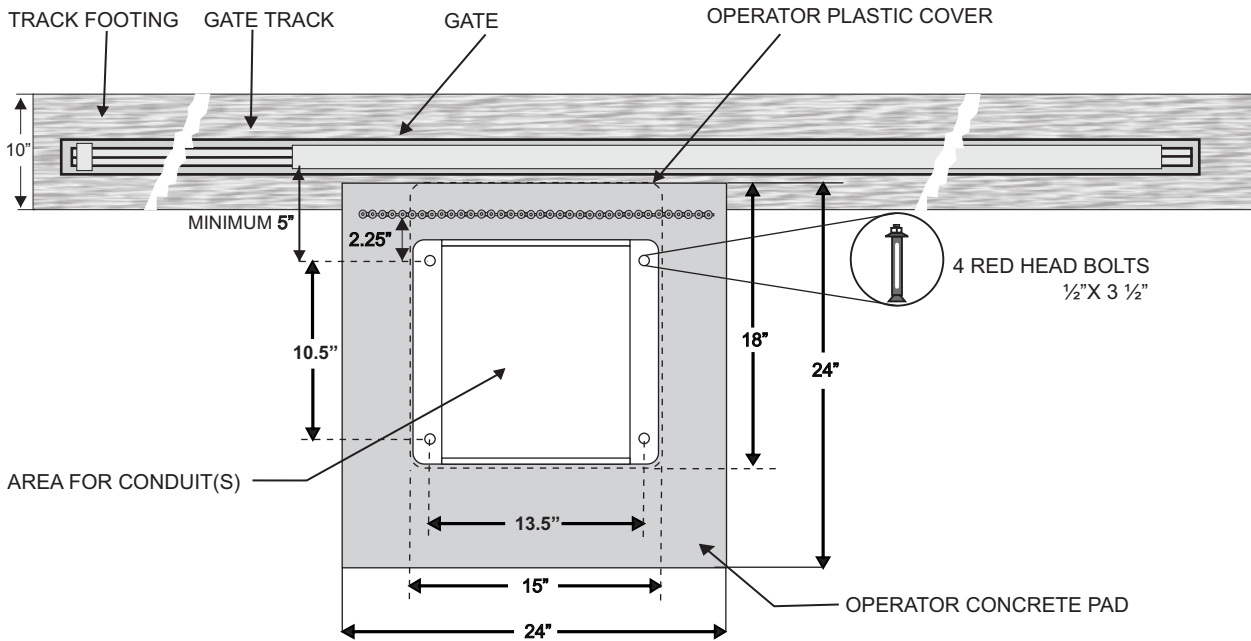

FRONT VIEW

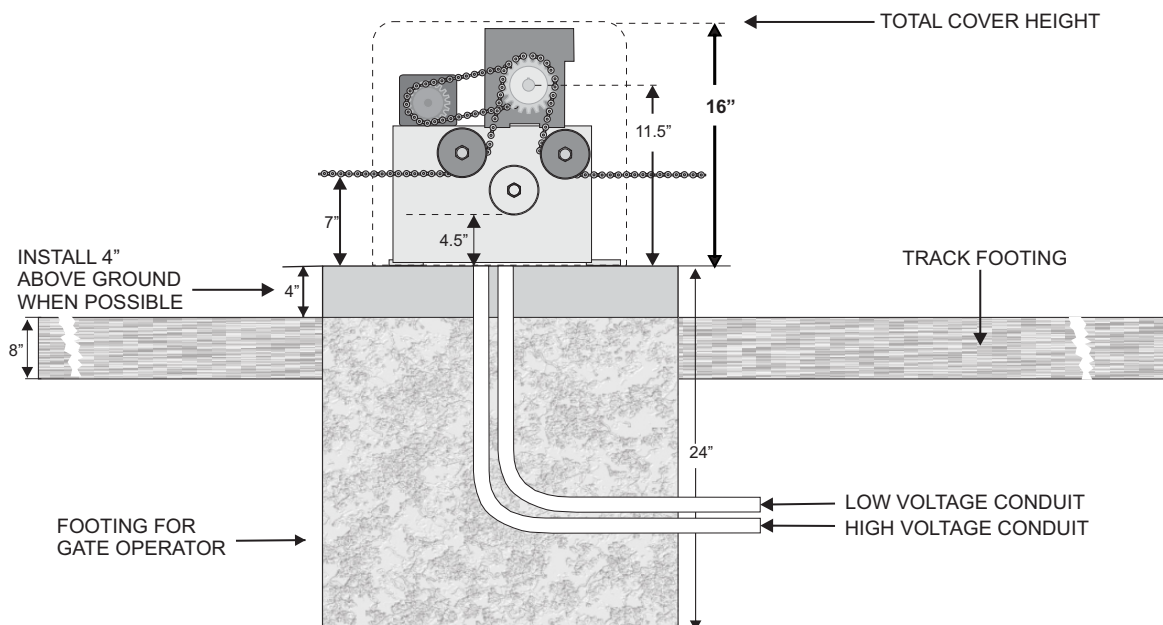

SL-100 DC [FP] CONCRETE PAD

TOP VIEW

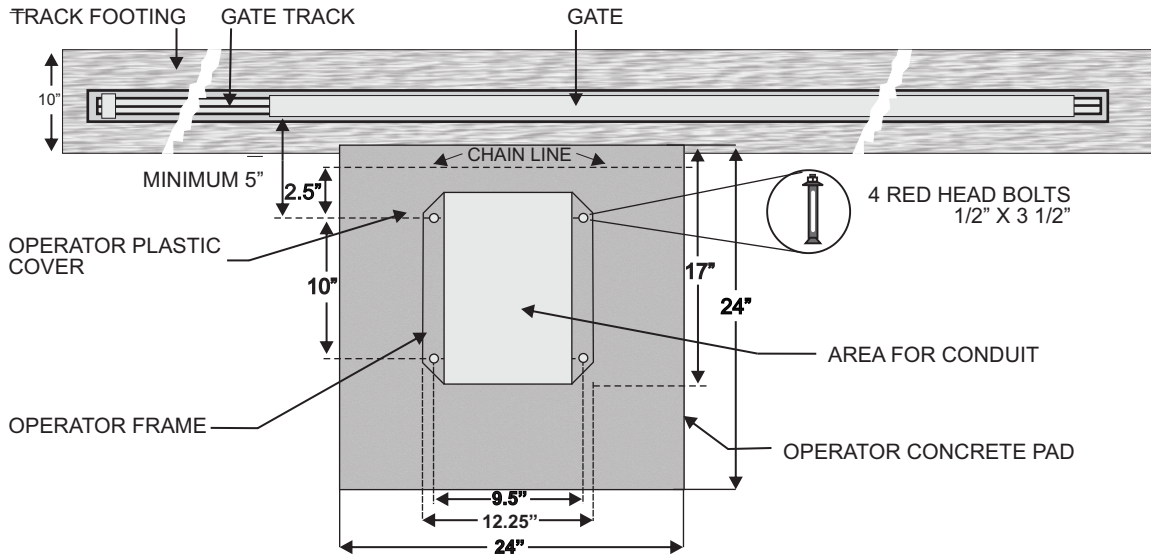

FRONT VIEW

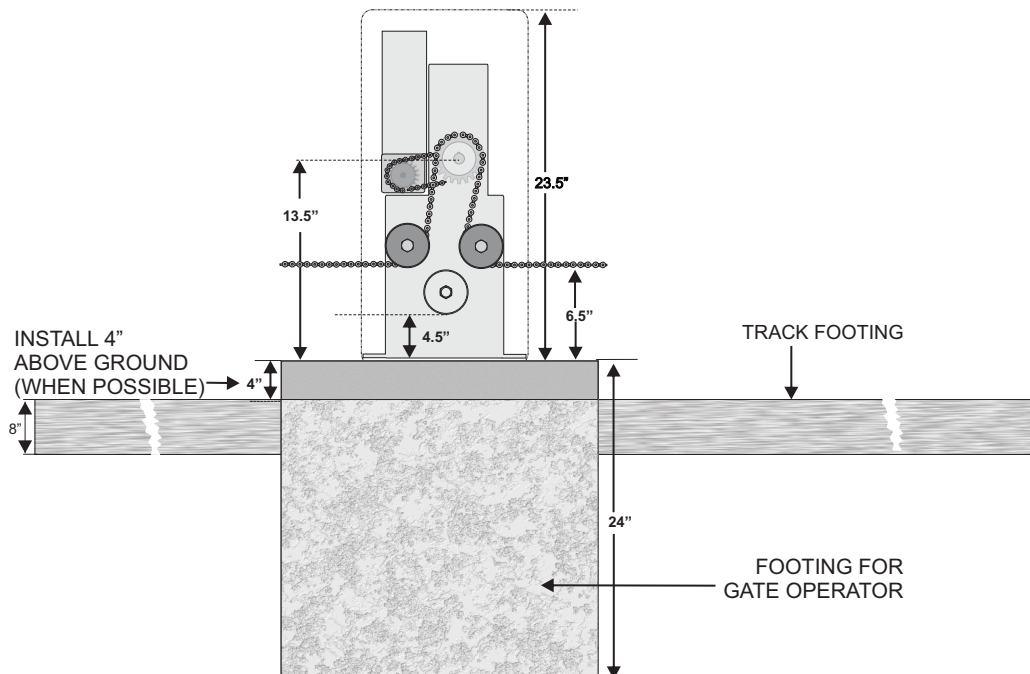

SL-150 DC CONCRETE PAD

TOP VIEW

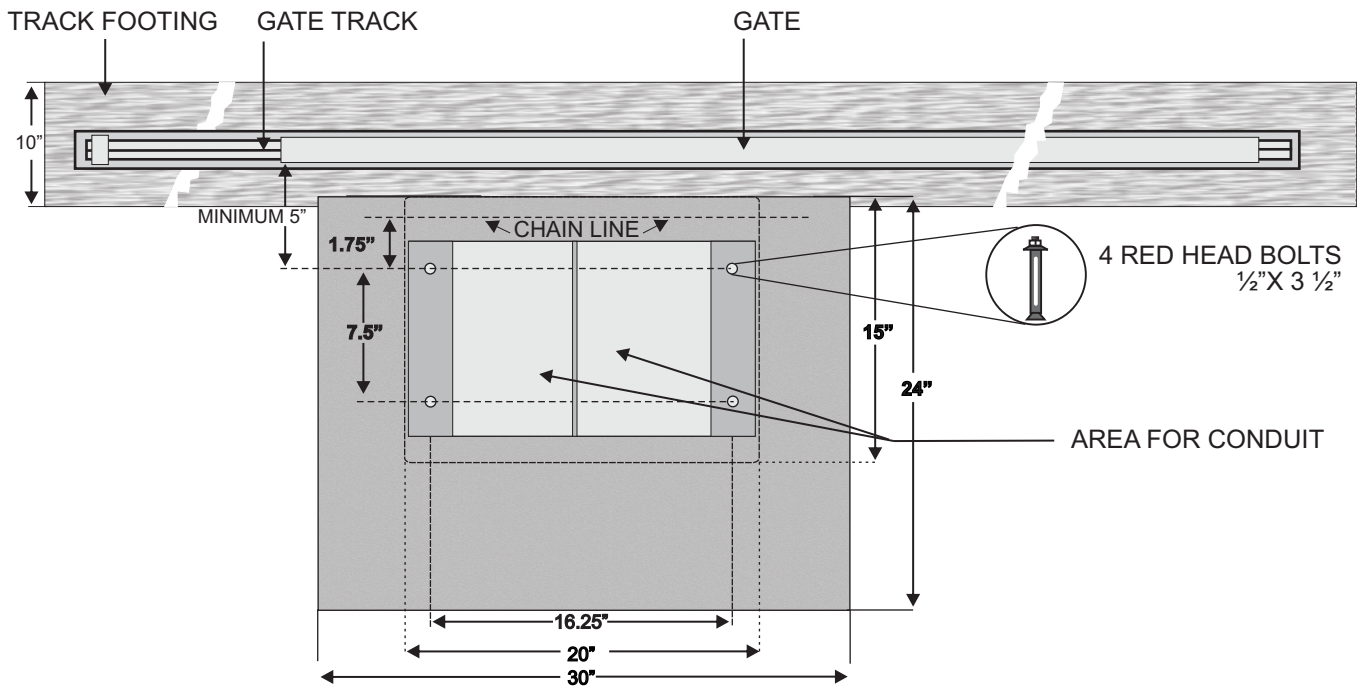

FRONT VIEW

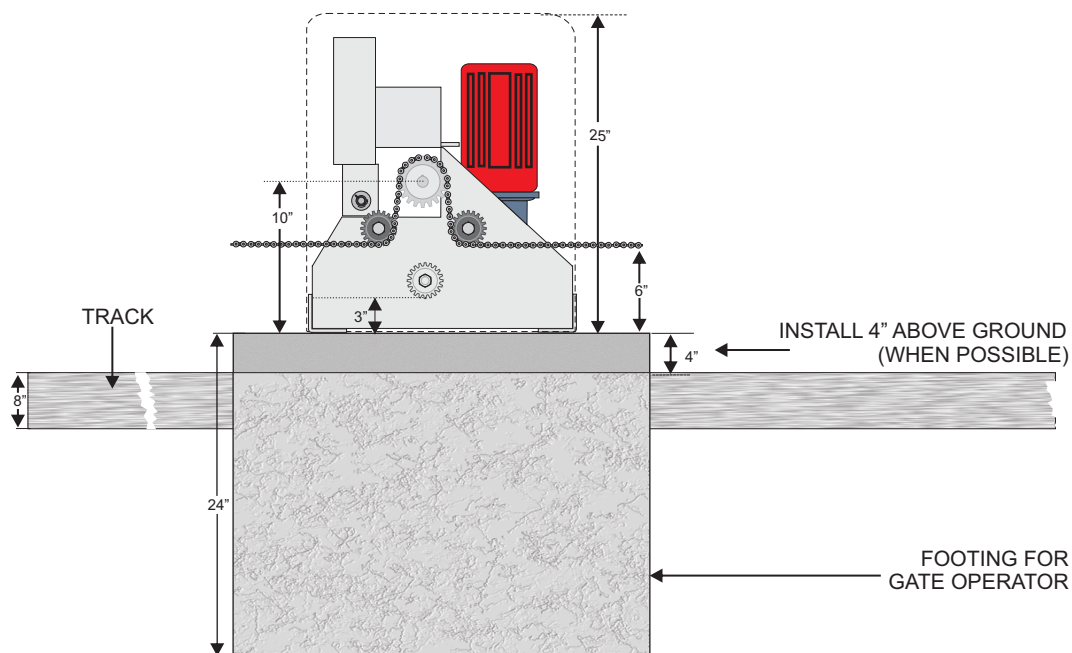

FRONT MOUNT INSTALLATION

FRONT VIEW

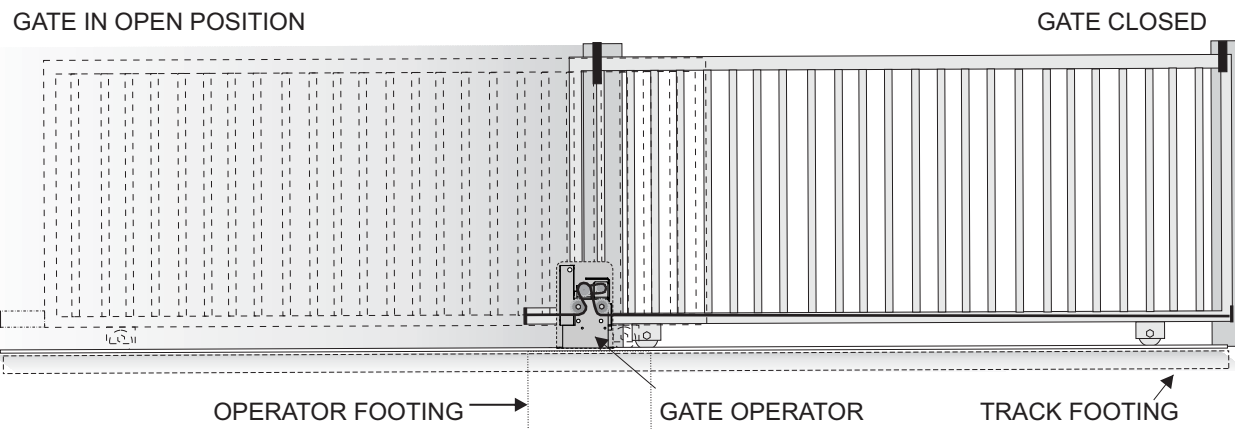

OVERHEAD VIEW

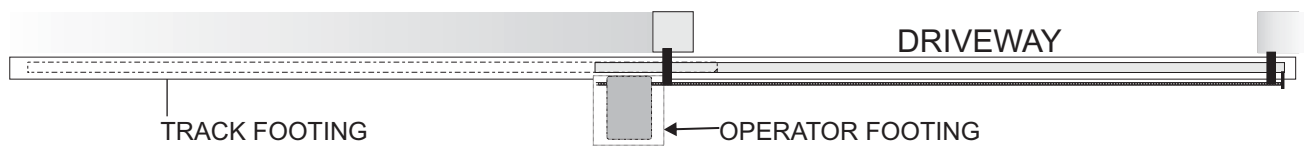

FRONT MOUNT INSTALLATION (CONTINUED)

SL-45 DC

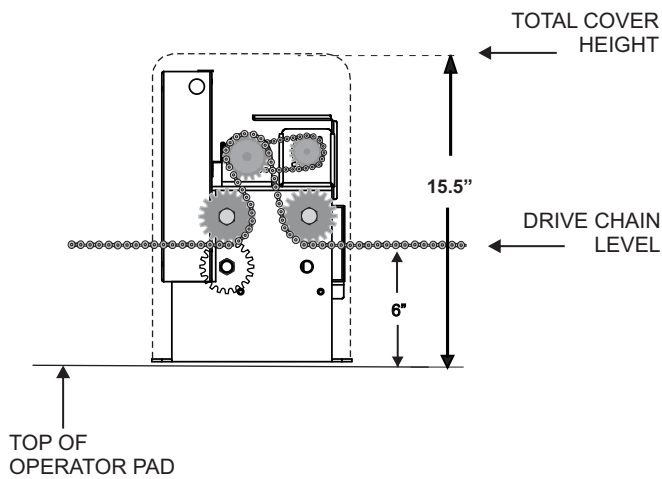

SL-90FP DC

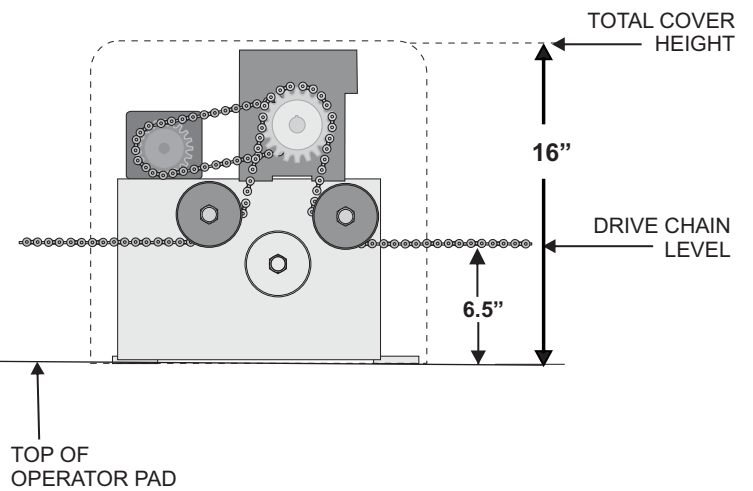

SL-100 DC & SL-100 DC FP

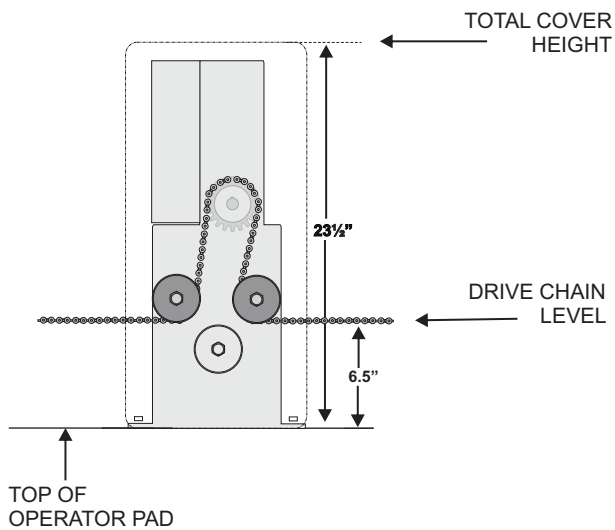

SL-150 DC

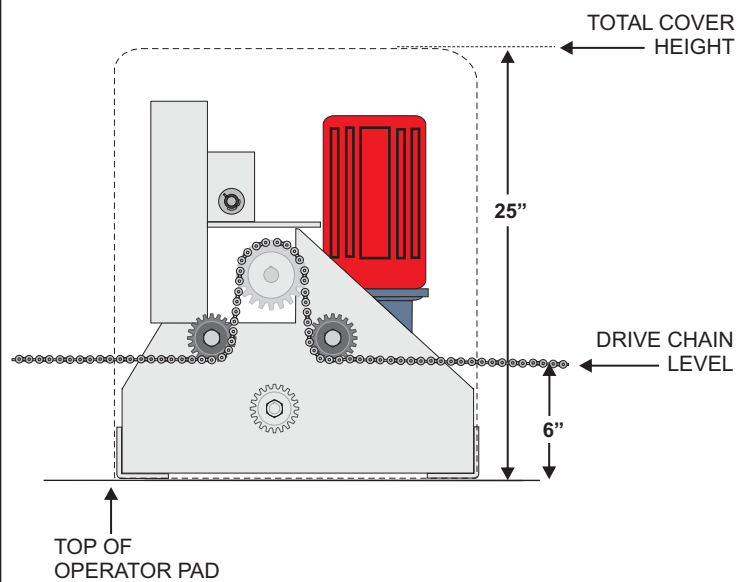

REAR MOUNT INSTALLATION

FRONT VIEW

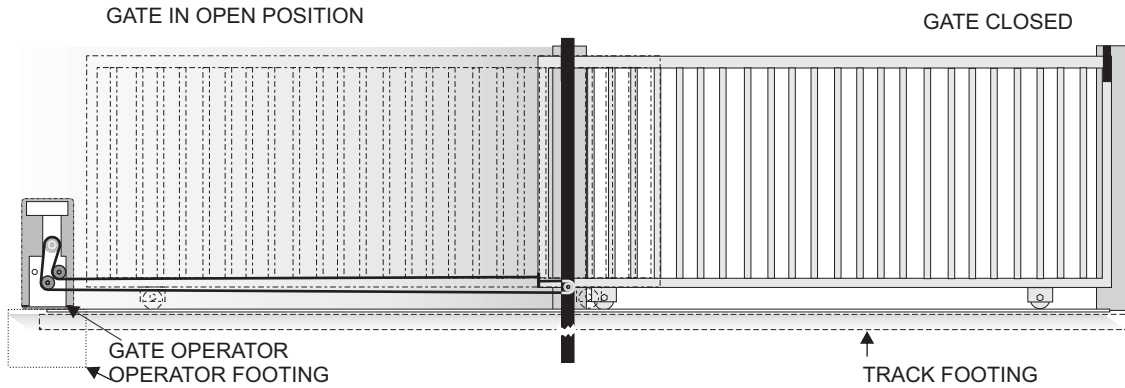

OVERHEAD VIEW

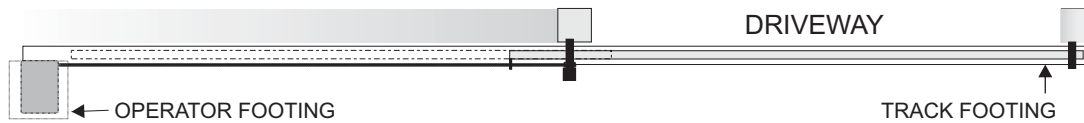

CHAIN CONNECTION TO GATE

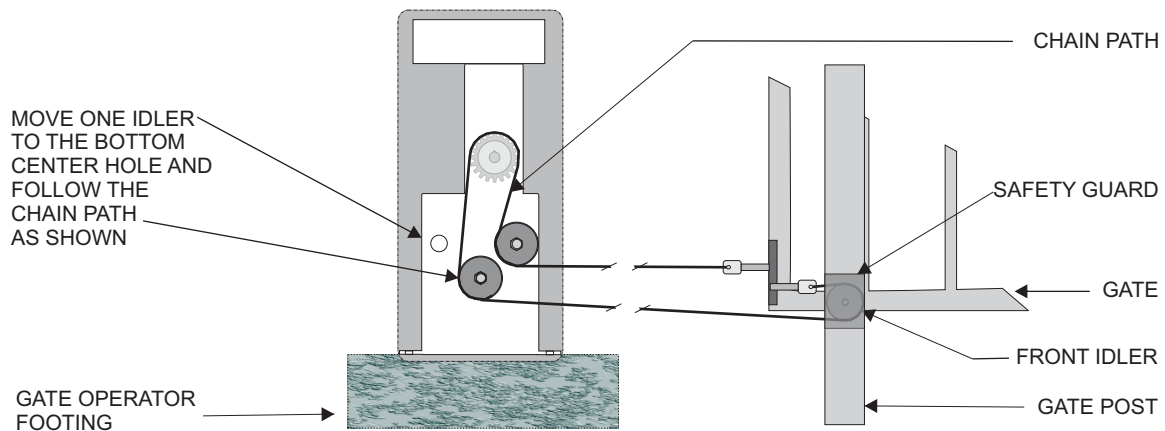

ENTRAPMENT PROTECTION INSTALLATION

- A minimum of (2) monitored entrapment protection devices are **REQUIRED** for each entrapment zone.
- An entrapment zone is a location or point of contact where a person can become entrapped between a moving gate and a rigid object.
- The operator is equipped with an inherent entrapment protection system (ERD).
- The gate operator requires an external monitored entrapment protection device (non-contact photoelectric sensor or contact edge) for each entrapment zone prior to gate operation. The operator cycles power to the external entrapment protection device and checks for device signals. If the operator does not receive the correct feedback from the device, the gate will not operate.

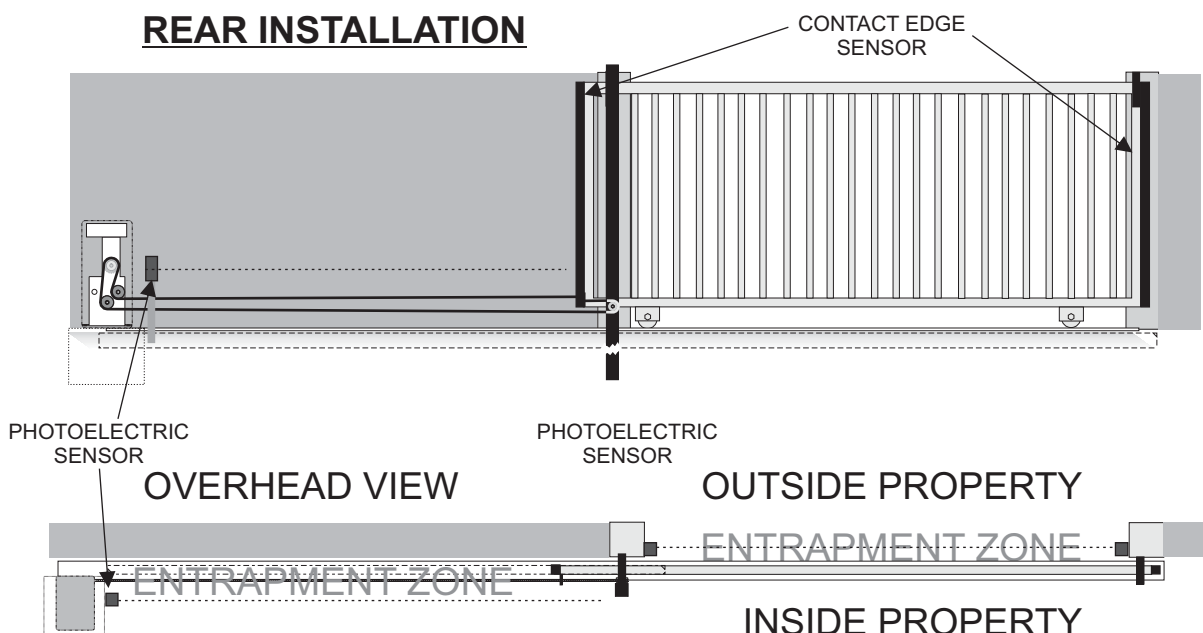
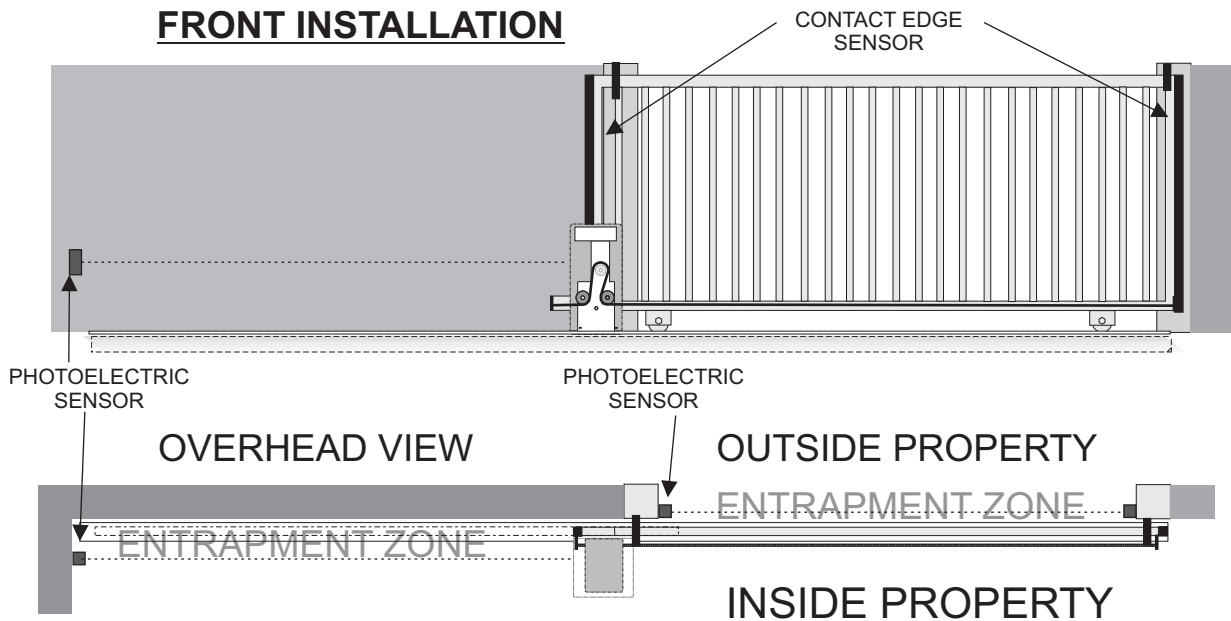

LOOP LAYOUT

- Below is a typical loop layout. When connecting to an All-O-Matic circuit board, use the following:
 - **SAFETY LOOP** - Normally Closed (N.C.) Contacts
 - **EXIT/OPEN CMD** - Normally Open (N.O.) Contacts(See page 27 for LPR-1 loop rack wiring)
- Wires **MUST** be twisted from the exit point of the loop saw cut to the loop detector.
- Twist loop wires 6 turns per foot, as shown below. Improper twisting of wires can cause loop issues.
- When using an inside and outside safety loop, loops must be **WIRED IN SERIES**.

OUTSIDE PROPERTY

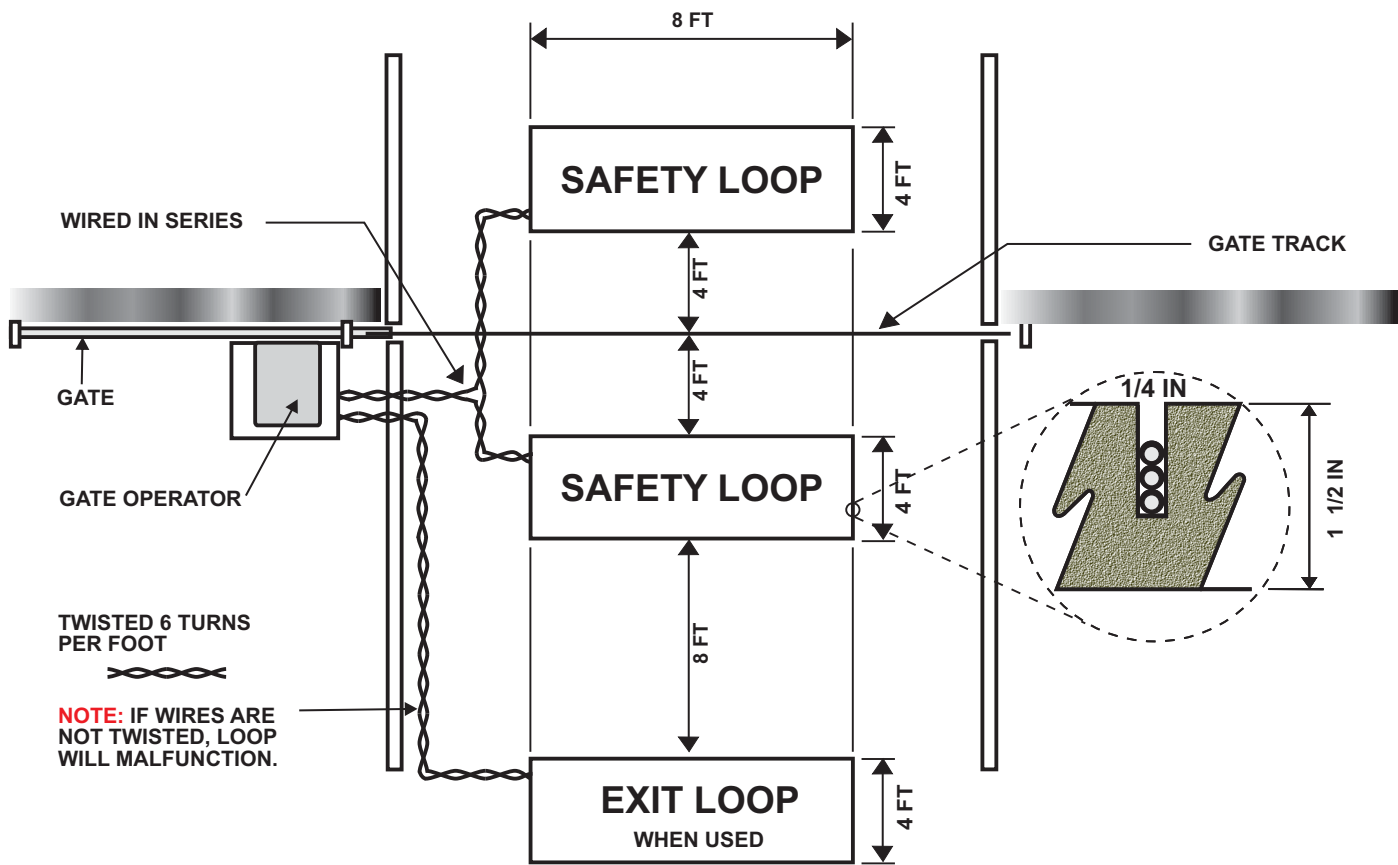

INSIDE PROPERTY

ELECTRICAL CONNECTION

OPERATORS MUST BE PROPERLY GROUNDED!

- All gate operators **MUST** be properly grounded. This minimizes or prevents damage due to electrical charge, such as a near lightning strike or an electrical static discharge.
- Use a single wire for the ground. **DO NOT** splice two wires for the ground. If the wire breaks or is cut, replace it with a single length wire. **NEVER** use two wires for the ground.
- Check the local city code for proper earth ground rod type and grounding procedures.
- Use UL listed conduits for power wire enclosure.

- Use a minimum of a **20-amp**, dedicated circuit for power.

Power	115 VAC 50/60Hz	230 VAC 50/60Hz Single Phase
LINE 1	115V HOT	230V LINE 1
LINE 2	115V NEUTRAL	230V LINE 2
GND	GROUND	GROUND

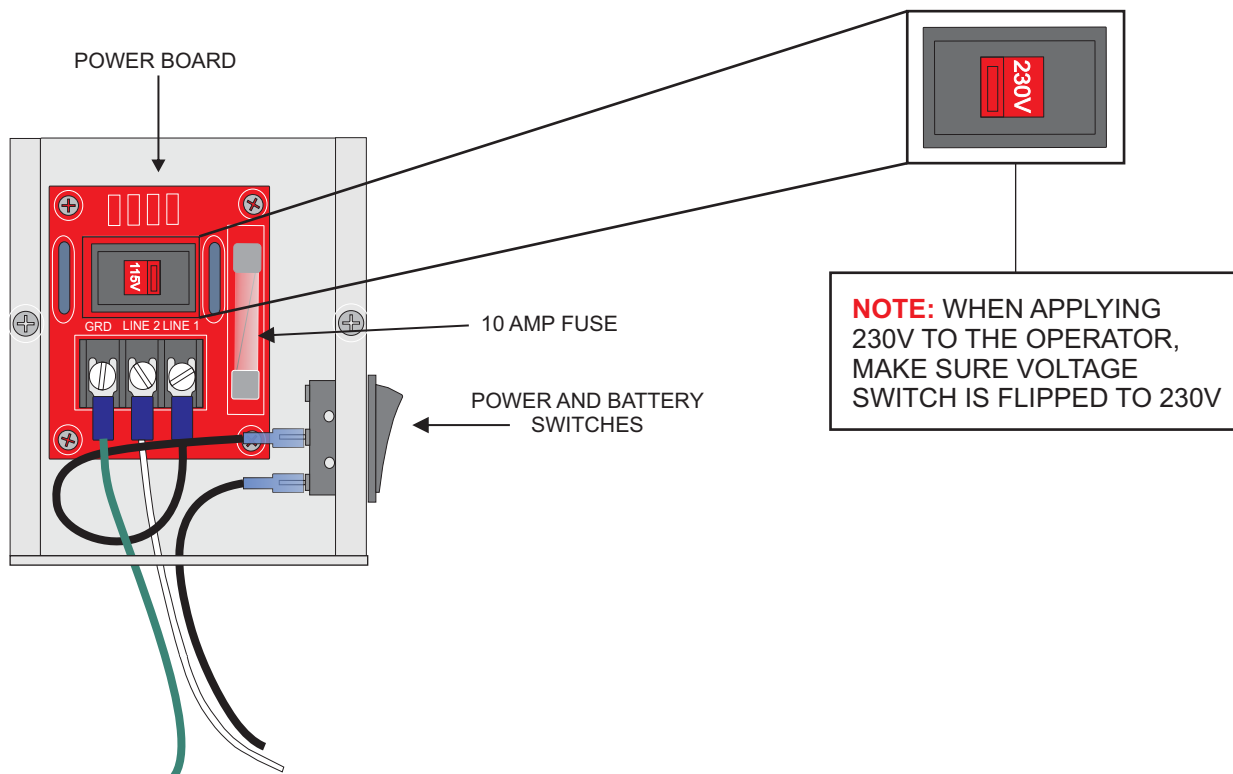

GATE TRAVEL ADJUSTMENT

Locate the limit switches (limit switches will be in the limit box on SL-150 DC) and follow the steps below:

- 1: Turn the power **OFF** on the operator.
- 2: Push the limit lock plate down (on the SL-45 DC, SL-90 DC, and SL-100 DC) or outwards (on the SL-150 DC)
- 3: Turn the limit nut toward the switch to **DECREASE** travel and away from the switch to **INCREASE** travel.
- 4: Place limit plate back to its locked position. (**MUST** be done for gate to hold its limits)
- 5: Turn the power **ON** to the operator.
- 6: Run the gate operator open and close. If additional adjustment is needed, repeat the steps.
- 7: When limits are set, move the gate to the closed position. Press and release "RESET" on the circuit board and run the gate one uninterrupted cycle (full open and full close) to learn the slow down.

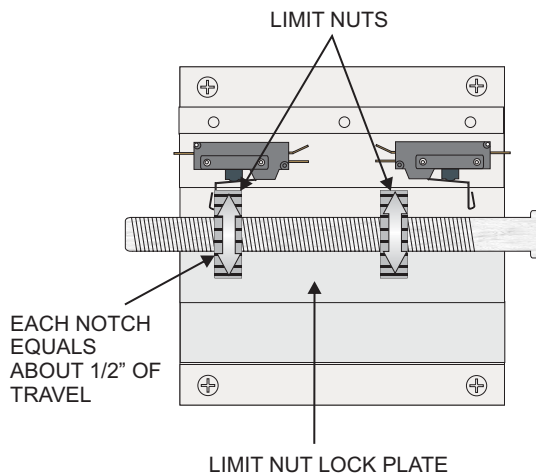

SL-45 DC
SL-90 DC
SL-100 DC[FP]

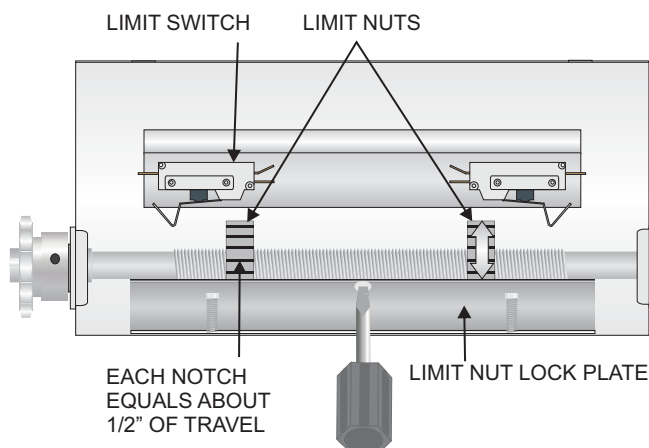

SL-150 DC

SL-150 DC CLUTCH ADJUSTMENT

The SL-150 DC gearbox is equipped with an internal clutch to protect the operator when gate is reversed in mid-cycle.

The clutch comes from the factory set at 60 lbs. of torque. In some applications, where the gates are heavier than normal, the clutch may require some adjustment to increase the amount of torque. It is important to have the clutch tight enough to be able to move the gate without slipping. It is as important to not over tighten the clutch, as it is a method of protecting the operator.

Follow these instructions to adjust the clutch when necessary:

- To increase the torque, use a pipe wrench to turn the clutch nut clockwise .
- Turn the nut 1/2 a turn at a time until the operator is able to move the load of the gate without the clutch slipping.
- Once the operator is able to move the gate without the clutch slipping, turn the nut one full turn. This will allow the operator to move the gate, but also slip when the gate is reversed mid cycle or in the event the gate gets jammed.

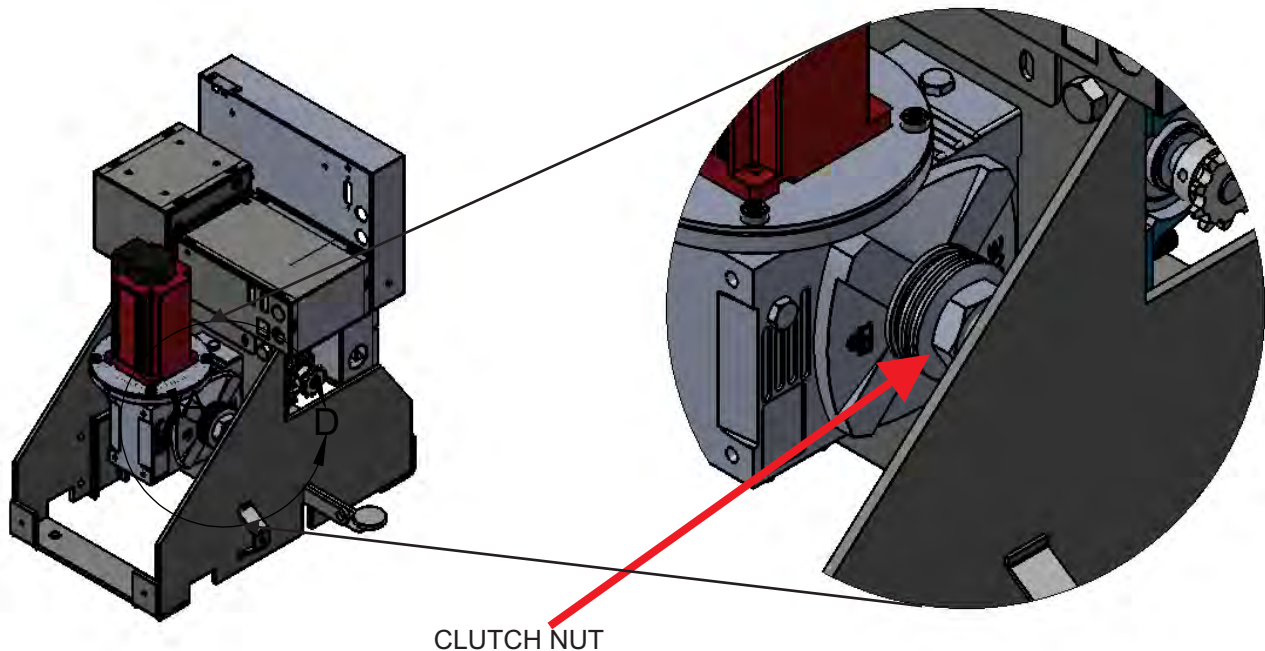

GATE OPENING DIRECTION SETTING

- Use OPEN L/R” dipswitch (#8) to change the opening direction of the operator.
- The direction of gate opening is determined from behind the gate operator.
- LEDs will show opening and closing direction when the gate is moving.
- OPEN L/R switch “OFF” is for left hand opening
- OPEN L/R switch “ON” is for right hand opening

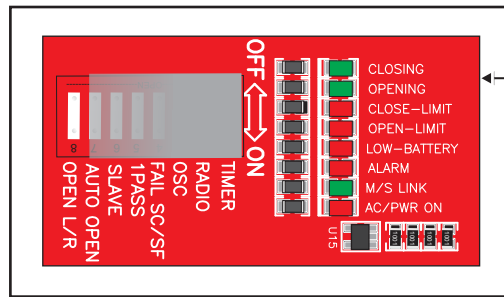

LEDs WILL SHOW
OPENING OR
CLOSING DIRECTIONS
WHEN THE GATE IS
RUNNING

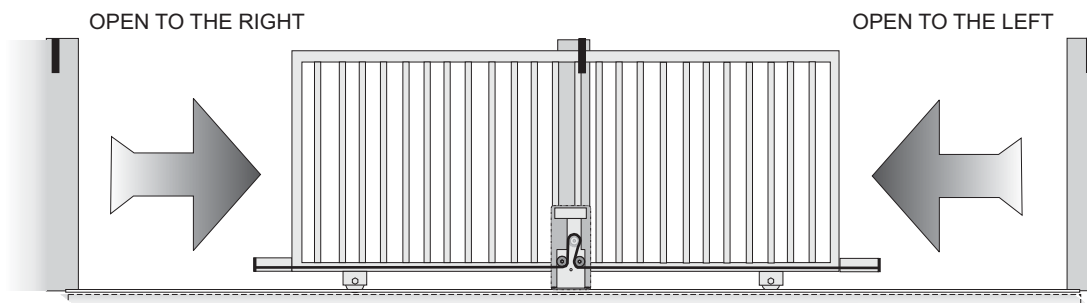
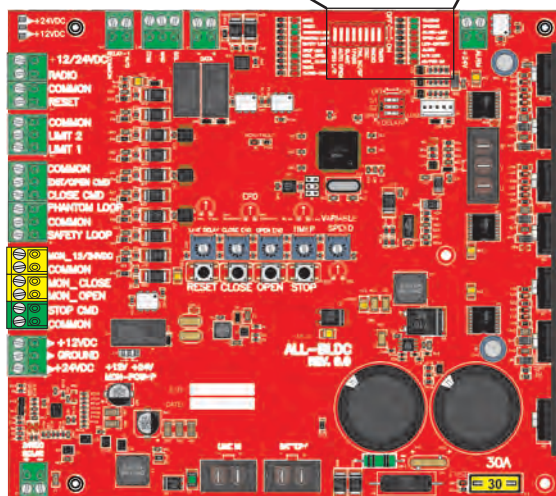

PROGRAMMABLE RELAY AND LEAF DELAY

RELAY SETTINGS

Board model ALL-BLDC includes a programmable relay (N.O.) with four different configurations. See table below for switch settings. Use the "Leaf Delay" potentiometer to adjust the delay time from 0 to 6 seconds.

- (1) 1 second pulse for every open start cycle
- Typically used for a cycle counter
- (2) "ON" when the gate is in motion
- Typically used for an audible alarm or strobe light to warn when the gate is in motion.
- (3) Alarm system output
- Activates the relay when the gate is forced open
- (4) "ON" when gate is not fully closed
- Typically used for a gate position indicator

S1	S2	RELAY FUNCTION
OFF	OFF	ONE SECOND PULSE FOR EVERY OPEN START
ON	OFF	ON WHEN GATE IS IN MOTION
OFF	ON	ALARM SYSTEM OUTPUT
ON	ON	ON WHEN GATE IS NOT FULLY CLOSED

DELAY SETTINGS

The ALL-BLDC board includes a delay option for open or close cycles. This delay option is most commonly used on swing gate applications. However, some slide gate applications may require a pre-warn strobe light or siren. In these applications this delay could be used for the pre-warn delay in conjunction with the RELAY function ON WHEN GATE IN MOTION.

Use the dip-switch 3 to set the desired delay direction.

- Flip the dip-switch 3 to the OFF position for the delay on opening direction
- Flip the dip-switch 3 to the ON position for delay on closing direction
- Use leaf delay potentiometer to adjust the delay
- It has adjustment from 0-6 seconds.
- Turn clockwise for less time
- Turn counter-clockwise for more time

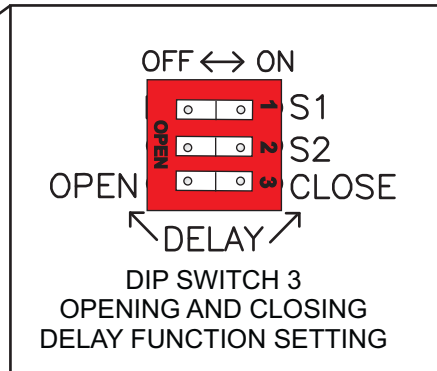
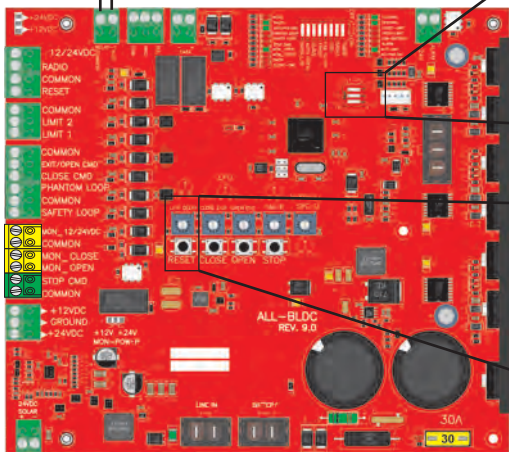

0 TO 6 SECOND DELAY ADJUSTMENT

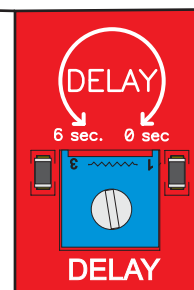

ELECTRONIC REVERSING DEVICE (ERD) ADJUSTMENT

All BLDC boards are equipped with an Electronic Reversing Device (ERD), which will cause the gate to reverse direction when it comes in contact with an obstruction.

The amount of force required to reverse the gate's direction depends on the ERD sensitivity setting.

The ERDs must be adjusted for the operator to provide regular, reliable & safe operations. If the gate reverses direction on its own without hitting an obstruction, the ERD is too sensitive. If the gate does not reverse when it hits an obstruction, the ERD is not sensitive enough.

The gate operator ERDs shall be tested and adjusted every six months by a qualified technician.

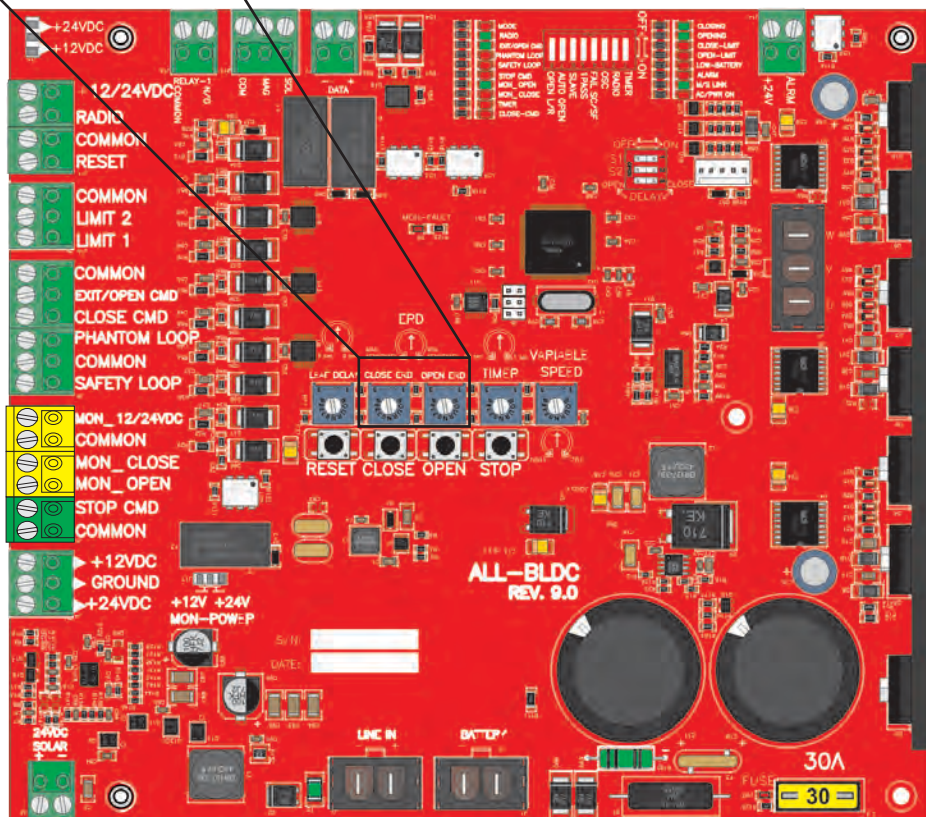
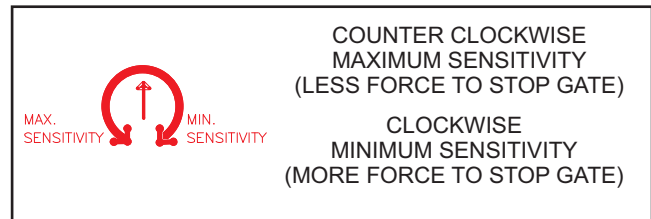
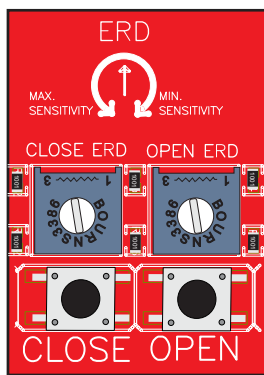

TIMER ADJUSTMENT AND RADIO SETTING

TIMER ON: Automatic timer to close can be set from 1 to 60 seconds

TIMER OFF: Gate operation is "push button to open, push button to close"

RADIO ON: To override the timer and allow the radio receiver to close the gate before the timer



Turn potentiometer counter clockwise for more time



Turn potentiometer clockwise for less time

NOTE: If Potentiometer is turned all the way counter clockwise, the timer is disabled and the gate WILL NOT close automatically.

TIMER "ON" TO
ACTIVATE THE TIMER

RADIO "ON" = ALLOWS THE
TRANSMITTER TO CLOSE
THE GATE BEFORE THE TIMER

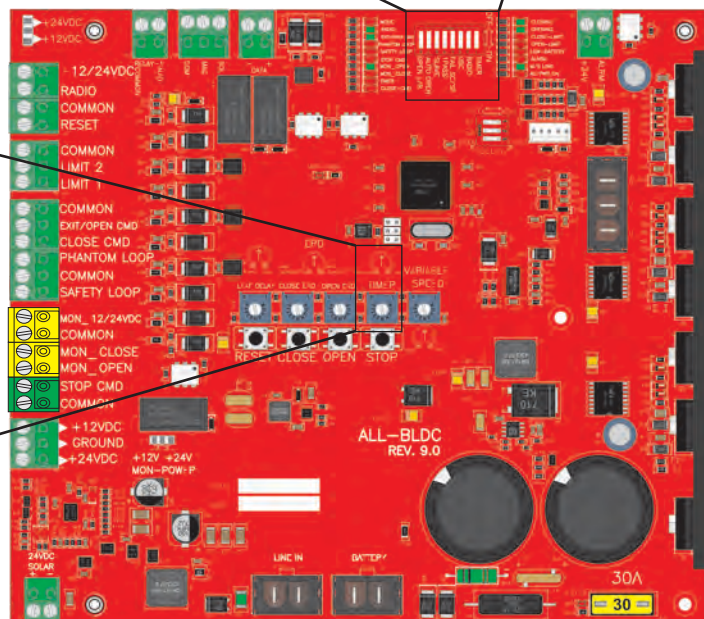
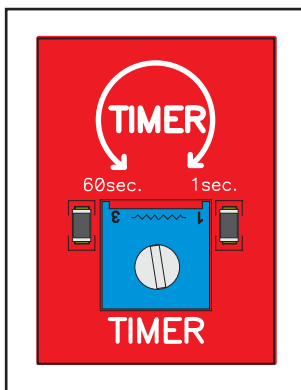
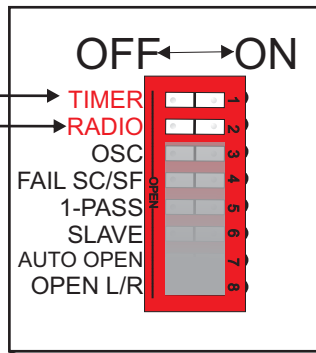

DIP SWITCH FUNCTIONS

TIMER

TIMER switch “ON” activates the automatic close timer.

RADIO

RADIO switch “ON” allows the radio receiver to override the automatic close timer.

OSC

OSC switch “ON” allows the radio receiver to stop and reverse the gate in any direction. During a cycle, the first signal stops the gate. A second signal reverses the gate.

FAIL SC/SF

ON for Fail-Safe: Upon power failure, board will monitor battery voltage to make sure gate opens before battery completely drains. **OFF for Fail-Secure:** Upon power failure, gate will run until battery is low and lock closed.

1-PASS

1-PASS switch “ON” allows the gate to open until one vehicle goes over the safety loop. Once the vehicle has cleared the loop, the gate will stop and close. If a second vehicle goes over the loop while the gate is closing, the gate will stop. The vehicle must get off of the loop before the gate continues to close, forcing the second vehicle to present valid credentials. This is a true one pass, anti-tailgating feature to be used with safety loops.

SLAVE

This feature is used in dual gate applications. The **SLAVE** switch will be “ON” only on the slave operator. All other dip switches will be “off”. **SLAVE** switch will be “OFF” on the master operator. Set desired dip switch settings on the master operator only.

AUTO OPEN

This feature is to automatically open the gate on power interruption. It is a very particular feature used in areas where the fire department requires the gate to open automatically after a power outage. Set this dip switch “ON” when this feature is desired.

OPEN L/R

OPEN L/R switch “ON” is used for right hand opening of the gate. The “OFF” position is used for left hand opening of the gate.

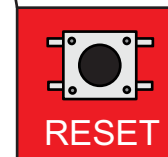
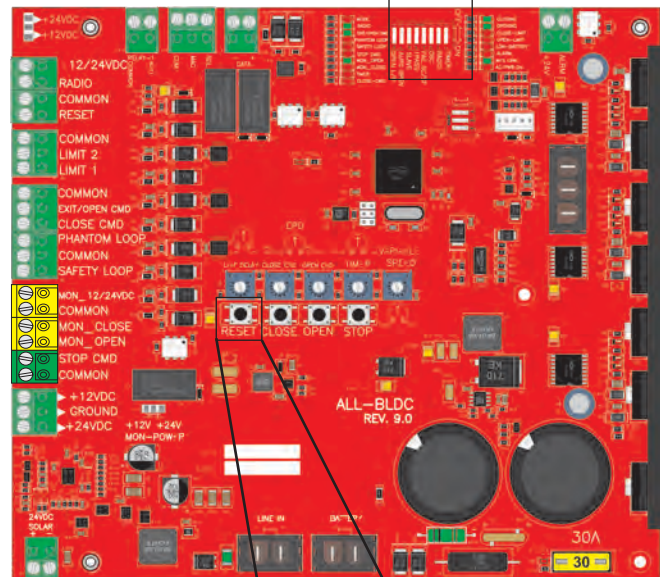
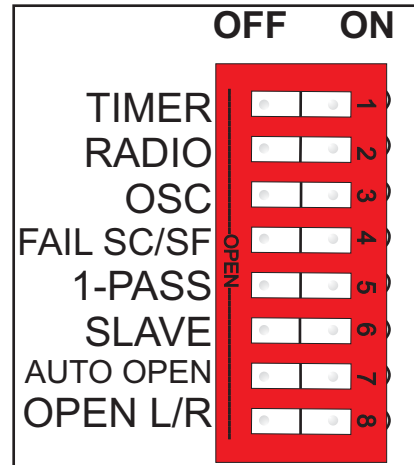

NOTE: IF ANY CHANGES ARE MADE TO THE DIPSWITCHES WITH THE POWER ON, PRESS THE **MAIN RESET** BUTTON TO RECOGNIZE THE CHANGES.

LED DIAGNOSTICS

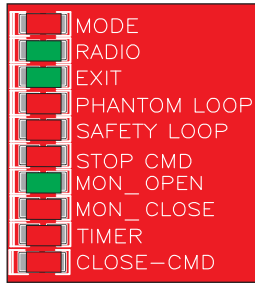

MODE

Blinks **once** every two seconds when there is a problem with the motor **hall sensor** feedback. Blinks twice every **two seconds** when a **motor overload** is detected. Blinks **three** times every two seconds when the gate is **jammed**.

RADIO

ON when the RADIO input is activated (closed circuit to common).

EXIT

ON when the EXIT input is activated (closed circuit to common).

PHANTOM LOOP

ON when the PHANTOM LOOP input is activated (closed circuit to common).

SAFETY LOOP

ON when the SAFETY LOOP input is activated (open circuit to common)

STOP CMD

ON when the STOP CMD input is activated (open circuit to common). Also when foot pedal is pressed down, on operators that include the foot pedal.

MON_OPEN

ON when the MON-OPEN input is activated (open circuit to open) or when a device is not installed.

MON_CLOSE

ON when the MON_CLOSE input is activated (open circuit to common) or when a device is not installed.

TIMER

Blinks when the timer is counting down to close automatically.

CLOSE-CMD

ON when the CLOSE-CMD input is activated (closed circuit to common).

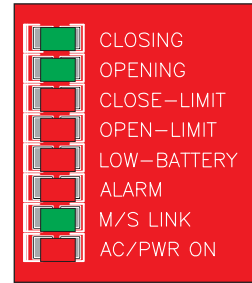

CLOSING

ON while the gate is in the close cycle.

OPENING

ON while the gate is in the open cycle.

CLOSE-LIMIT

ON while the limit nut is activating the close limit switch.

OPEN-LIMIT

ON while the limit nut is activating the open limit switch.

LOW-BATTERY

ON when the batteries are low.

ALARM

Blinks every 30 seconds (alarm will also beep) when the batteries are low, bad, or disconnected. Turns on for 5 minutes (alarms also goes off) when the operator goes into shut down mode due to the gate hitting an obstruction (ERD).

M/S LINK

ON when master/slave communication is active.

AC/PWR ON

ON when AC power is on.

TIPS: When troubleshooting, it is important to note what lights are ON. It is very helpful to pay attention to the lights as they tell us what the boards is doing and what inputs are active.

When calling ALL-O-MATIC for technical support please have the name of the lights that are ON in the control board. This will speed up the process to get the gate operator up and running.

ACCESSORY CONNECTIONS

The circuit board has 12/24VDC terminals that provide up to 750mAmps on 24VDC and 500mAmps on 12VDC to power accessories such as loop detectors, keypads, etc. If the total current draw of your accessories exceeds the rated current for any of the 12/24VDC terminals, a separate power supply (transformer) is required.

When installing a safety loop detector or pedestrian switch (STOP_CMD), make sure to remove the black jumper between the COMMON and SAFETY terminal for the safety detector and/or black jumper between STOP_CMD and COMMON for pedestrian switch.

NO Contacts	NC Contacts
Exit Loop Detector	Safety Loop Detector
Keypad	Photo Eye
Telephone System	Pedestrian Switch
Push Button	
Card Reader	

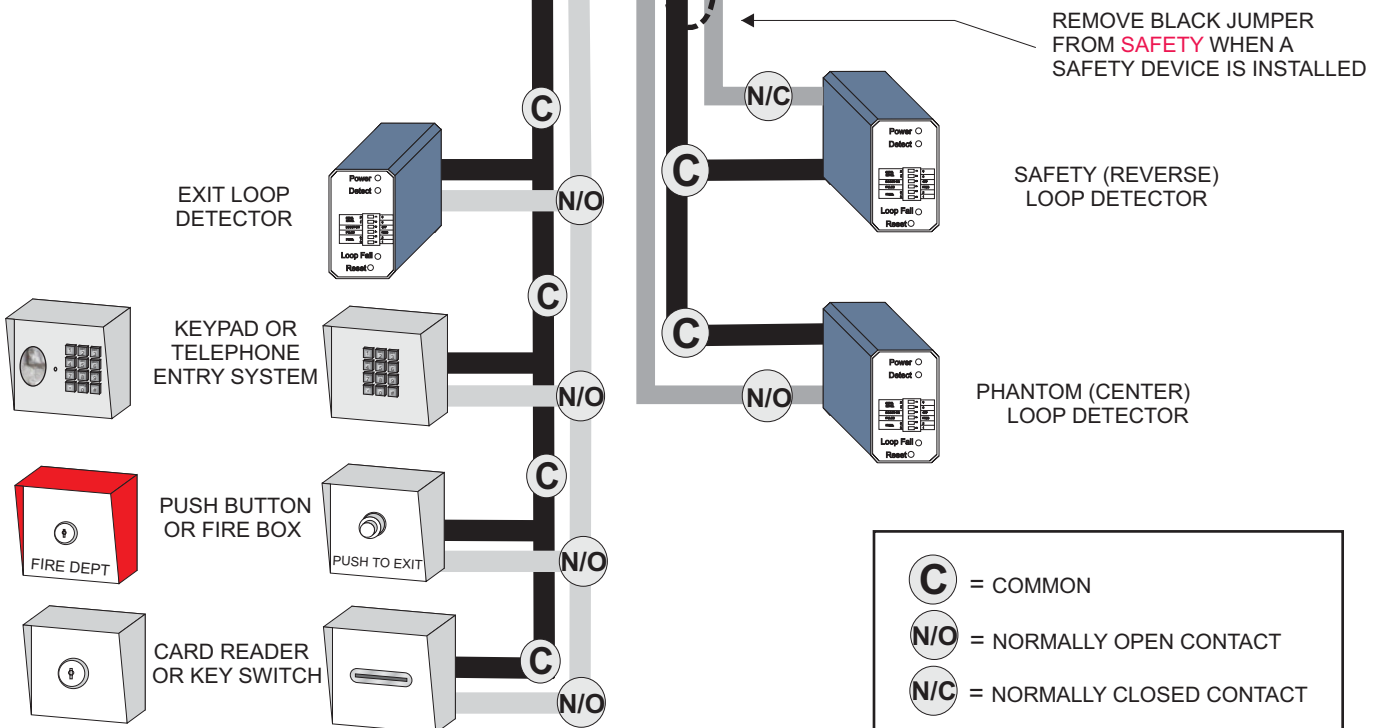
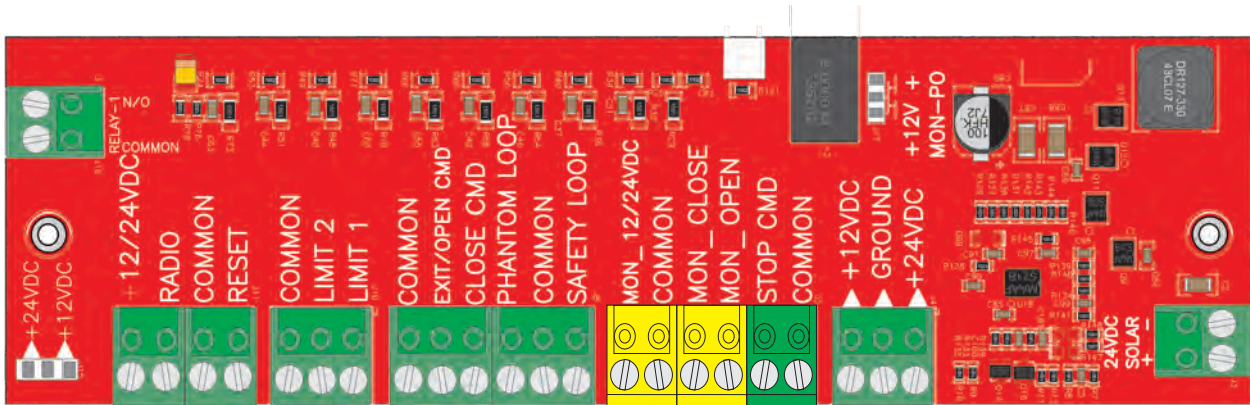

MONITORED ENTRAPMENT PROTECTION DEVICE CONNECTIONS

- There are 2 types of sensors that can be connected to the gate operator for UL 325 monitored entrapment compliance: non-contact sensors (photo eye) and contact sensors (edge sensors).
- Monitored entrapment protection devices use 4 wires to connect to the board. From the device, connect the **RELAY COMMON** to the board **COMMON** and the **NORMALLY CLOSED** relay contact to the assigned **MON_OPEN** or **MON_CLOSE** input. Connect the power wires to the **COMMON** and **MON-12/24VDC**.
- **IMPORTANT:** You must use the MON-12/24VDC to properly monitor entrapment protection devices. To turn this voltage on for **initial setup**, press reset button on the board. Do not use the 24 VDC terminal on the board's terminal strip.
- **NOTE:** The power to the **MON-12/24VDC** terminal will be off when the gate is at rest (not moving). It will be normal to see the **MON_OPEN** and **MON_CLOSE** LEDs when the gate is closed. If the auto close timer is **OFF** it will do the same when the gate is at rest in the open position. Also, if no devices are connected both of these lights will stay ON.
- Please refer to the device manufacturer wiring instructions for details (on next page), making sure to follow the normally closed wiring directions. Some devices may work on monitoring interfaces other than normally closed.
- Should there be a need for more than 1 entrapment protection device for each direction, use a multi-input module from Miller Edge (model: MIM-62).

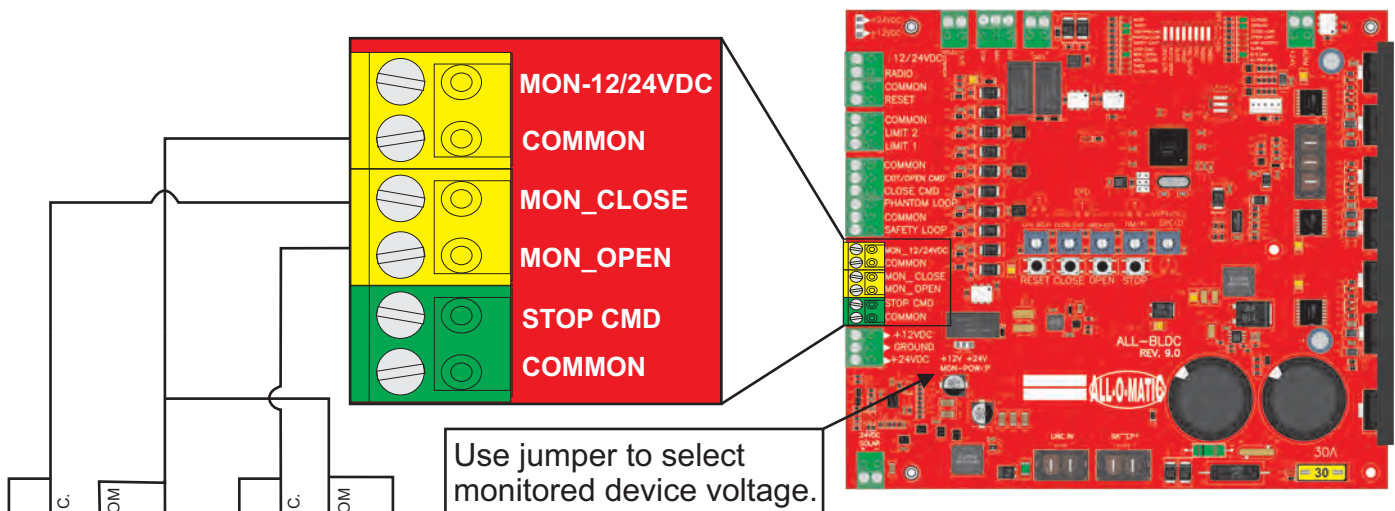

MON_CLOSE (LED will indicate when an obstruction is detected or device is not present)
 This input is only for the monitored entrapment protection device for the close direction. When the gate is closing, it will open to the full open position if an obstruction is sensed and resets the automatic close timer. This input does nothing in the opening direction. If a device is not connected or the board senses a fault (MON_FAULT LED will turn on), the operator will only work with a constant pressure actuated switch. Once the obstruction is cleared, the gate will operate normally.

MON_OPEN (LED will indicate when an obstruction is detected or device is not present)
 This input is only for the monitored entrapment protection device for the open direction. When the gate is opening, it will reverse for 2 seconds and stop if it senses an obstruction. This input does nothing in the closing direction. If a device is connected and the board detects a fault (MON_FAULT LED will turn on), the operator will only work with a constant pressure actuated switch. Once the obstruction is cleared, the gate will operate normally.

MONITORED ENTRAPMENT PROTECTION DEVICE CONNECTIONS

ENFORCER E-960-D90GQ/ E-931-S33RRGQ / E-931-S50RRGQ	
CONTACT	BOARD TERMINAL
N.C.	MON_CLOSE OR MON_OPEN
COM	COMMON
12-30 VDC/AC	COMMON
12-30 VDC/AC	MON_12/24VDC

ENFORCER E-936-S45RRGQ	
WIRE	BOARD TERMINAL
BLACK	MON_CLOSE OR MON_OPEN
WHITE	COMMON
BLUE	COMMON
BROWN	MON_12/24VDC

ALLEN BRADLEY GRU-24	
WIRE	BOARD TERMINAL
BLACK	MON_CLOSE OR MON_OPEN
ORANGE	COMMON
BLUE	COMMON
BROWN	MON_12/24VDC

OMRON E3K-R10K4-NR		
SWITCH	CONTACT	BOARD TERMINAL
LIGHT ON	N.O.2	MON_CLOSE OR MON_OPEN
	C.2	COMMON
	24 TO 240 VAC	COMMON
	24 TO 240 VAC	MON_12/24VDC

EMX IRB-MON		
SWITCH	CONTACT	BOARD TERMINAL
SW1 - OFF	N.C.	MON_CLOSE OR MON_OPEN
SW2 - OFF	COM	COMMON
SW3 - ON	POWER/ VRX	COMMON
SW4 - OFF	POWER/ VRX	MON_12/24VDC

EMX IRB-325	
CONTACT	BOARD TERMINAL
N.C.	MON_CLOSE OR MON_OPEN
COM	COMMON
POWER	COMMON
POWER	MON_12/24VDC

EMX NIR-50-325	
WIRE	BOARD TERMINAL
BLACK	MON_CLOSE OR MON_OPEN
WHITE	COMMON
BLUE	COMMON
BROWN	MON_12/24VDC

EMX IRB-RET		
SWITCH	CONTACT	BOARD TERMINAL
SW1 - OFF	N.C.	MON_CLOSE OR MON_OPEN
SW2 - OFF	COM	COMMON
SW3 - OFF	POWER/ VRX	COMMON
SW4 - ON	POWER/ VRX	MON_12/24VDC

TRANSMITTER SOLUTIONS R50R-UL/R32P-UL/SR33HD/SR66HD	
CONTACT	BOARD TERMINAL
N.C. (3)	MON_CLOSE OR MON_OPEN
COM (5)	COMMON
NON POLARITY (1)	COMMON
12-30 VDC/AC (2)	MON_12/24VDC

TRANSMITTER SOLUTIONS iGAZE RE KIT		
SWITCH	CONTACT	BOARD TERMINAL
ALL OFF	N.C.1	MON_CLOSE OR MON_OPEN
	COM	COMMON
	(-) 12/24 VDC	COMMON
	(+) 12/24 VDC	MON_12/24VDC

EMX WEL-200	
CONTACT	BOARD TERMINAL
RELAY CLOSE (NC) RELAY OPEN (NC)	MON_CLOSE MON_OPEN
RELAY CLOSE (COM) RELAY OPEN (COM)	COMMON COMMON
POWER	COMMON
POWER	MON_12/24VDC

MILLER EDGE R BAND 6 WIRES FOR 1 EDGE - 8 WIRES FOR 2 EDGES		
SWITCH	CONTACT	BOARD TERMINAL
SW 1 - ON	N/C N/C	MON_CLOSE MON_OPEN
SW 2 - ON	COM COM	COMMON COMMON
SW 3 - ON	COM A.TEST	COMMON MON_12/24VDC
SW 4 - ON	12/24 (+) AC/DC	24-VDC GROUND

MON_CLOSE = PROTECTS ACROSS THE DRIVEWAY/CLOSING DIRECTION
MON_OPEN = PROTECTS THE REAR SLIDE / OPENING DIRECTION

MONITORED ENTRAPMENT PROTECTION DEVICE CONNECTIONS

OVERHEAD VIEW OF DRIVEWAY

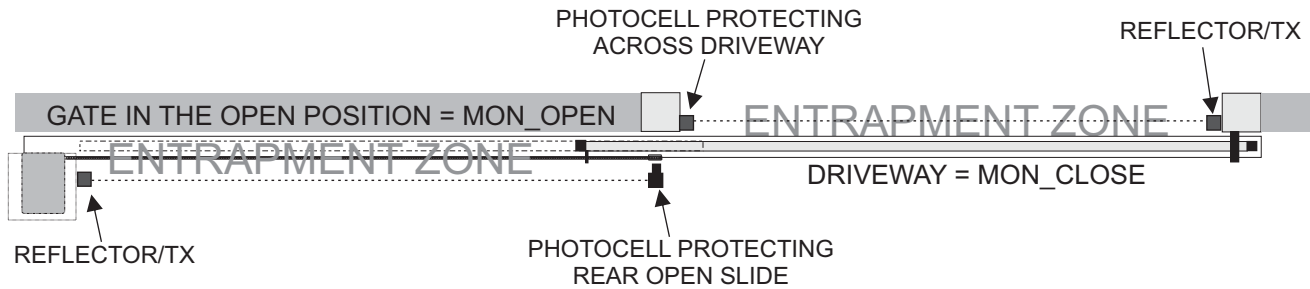

WIRING ENTRAPMENT DEVICE TO DC BOARD

(RED, BLUE AND GOLD BOARDS)

WIRING DEVICE ACROSS DRIVEWAY / CLOSE DIRECTION (MON_CLOSE)

WIRE TO THE YELLOW CONNECTOR

FOR OMRON E3K,
USE RELAY C2 AND NO 2
ENFORCER PHOTOCELL
MODELS MUST END IN -GQ

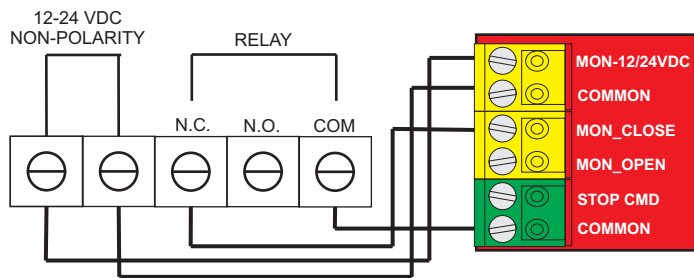

WIRING DEVICE FOR OPEN DIRECTION (MON_OPEN)

WIRE TO THE YELLOW CONNECTOR

FOR OMRON E3K,
USE RELAY C2 AND NO 2
ENFORCER PHOTOCELL
MODELS MUST END IN -GQ

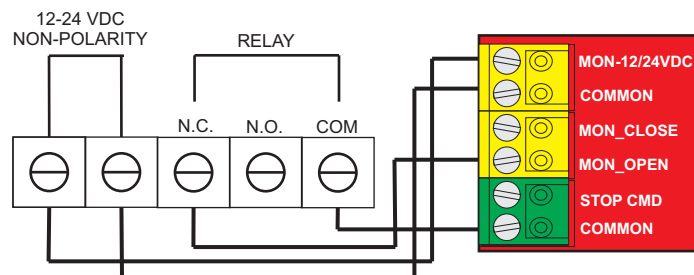

PLUG-IN DETECTOR INSTALLATION

- The SL-90 DC, SL-100 DC and SL-150DC models come equipped with the pre-wired LPR-2 loop rack for safety and exit plug in loop detectors, making installation quick and efficient.
- Hardwired loop detectors with harnesses can also be installed. The circuit board has 12 VDC and 24 VDC terminals to power the detector of your choice. See “Accessory Connections” page for wiring instructions.
- Wire one or more safety devices in series with the loop rack wires. To do this, remove the white wire (N.C) from the loop rack off of the SAFETY terminal on the circuit board and wire nut to the COM of the additional device. The N.C. contact of the additional device will now go on the SAFETY terminal of the board.
- **IMPORTANT:** Use different frequencies for each loop detector to eliminate interference.

LOOP RACK	DC BOARD	WIRE COLOR
12VdC	12-VDC	RED
GROUND	GROUND	BLACK
EXIT	EXIT	GREEN
PHANTOM	PHANTOM	BROWN
SAFETY	SAFETY	WHITE

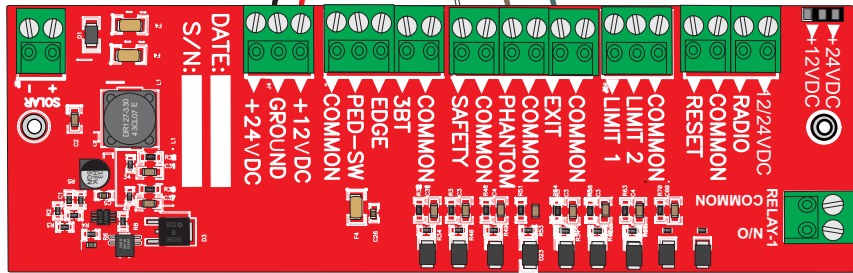
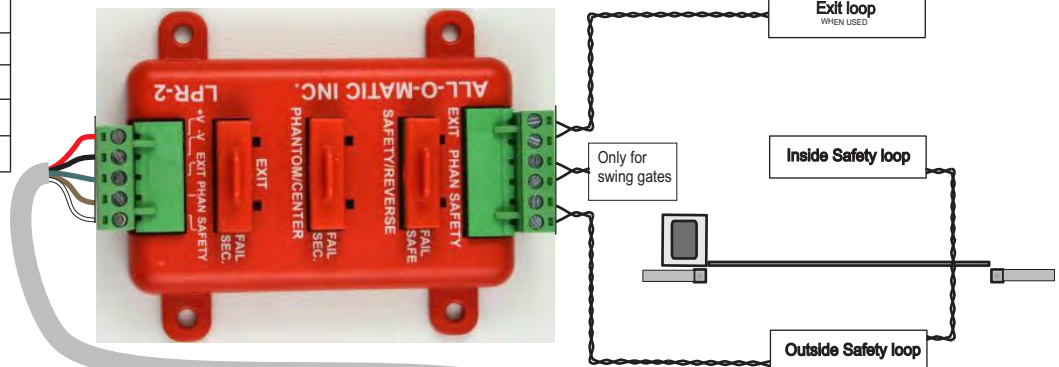

IMPORTANT: Dip switch **SW3** must be set when installing the detector in order for it to work properly.

Use chart below to set the output of the detector either **FAIL-SECURE** (N.O.) or **FAIL-SAFE** (N.C.).

OFF will set the output as **FAIL-SECURE** and **ON** will set output as **FAIL-SAFE**. See chart below.

OUTPUT	SW3
EXIT/PHANTOM	OFF
SAFETY	ON

PRIME-VD1

VEHICLE DETECTOR

INDICATORS:
 RED - DETECT
 GREEN - PWR/LOOP FAIL

SETTINGS

SENSITIVITY	SW1	SW2
LOW	OFF	OFF
MEDIUM LOW	ON	OFF
MEDIUM HI	OFF	ON
HIGH	ON	ON

GREEN LED BLINKING INDICATE LOOP FAIL:
 1 BLINK - OPEN LOOP
 2 BLINKS - LOOP SHORTED

OUTPUT	SW3
FAIL-SECURE	OFF
FAIL-SAFE	ON

USE FAIL-SAFE FOR SAFETY/
 REVERSE LOOP, FAIL-SECURE
 FOR EXIT OR PHANTOM LOOPS.

PRESS RESET AFTER CHANGING SENSITIVITY
 AND FREQUENCY SETTINGS

FREQUENCY	SW5	SW6
HIGH	OFF	OFF
MEDIUM HI	ON	OFF
MEDIUM LOW	OFF	ON
LOW	ON	ON

THREE BUTTON STATION CONNECTION

- A three button station and reset push button are integrated on the board to make limit and ERD adjustments easier.
- An external three button station may also be installed. See diagram below for wiring instructions.
- **NOTE:** STOP_CMD jumper must be removed if a three button station is installed.

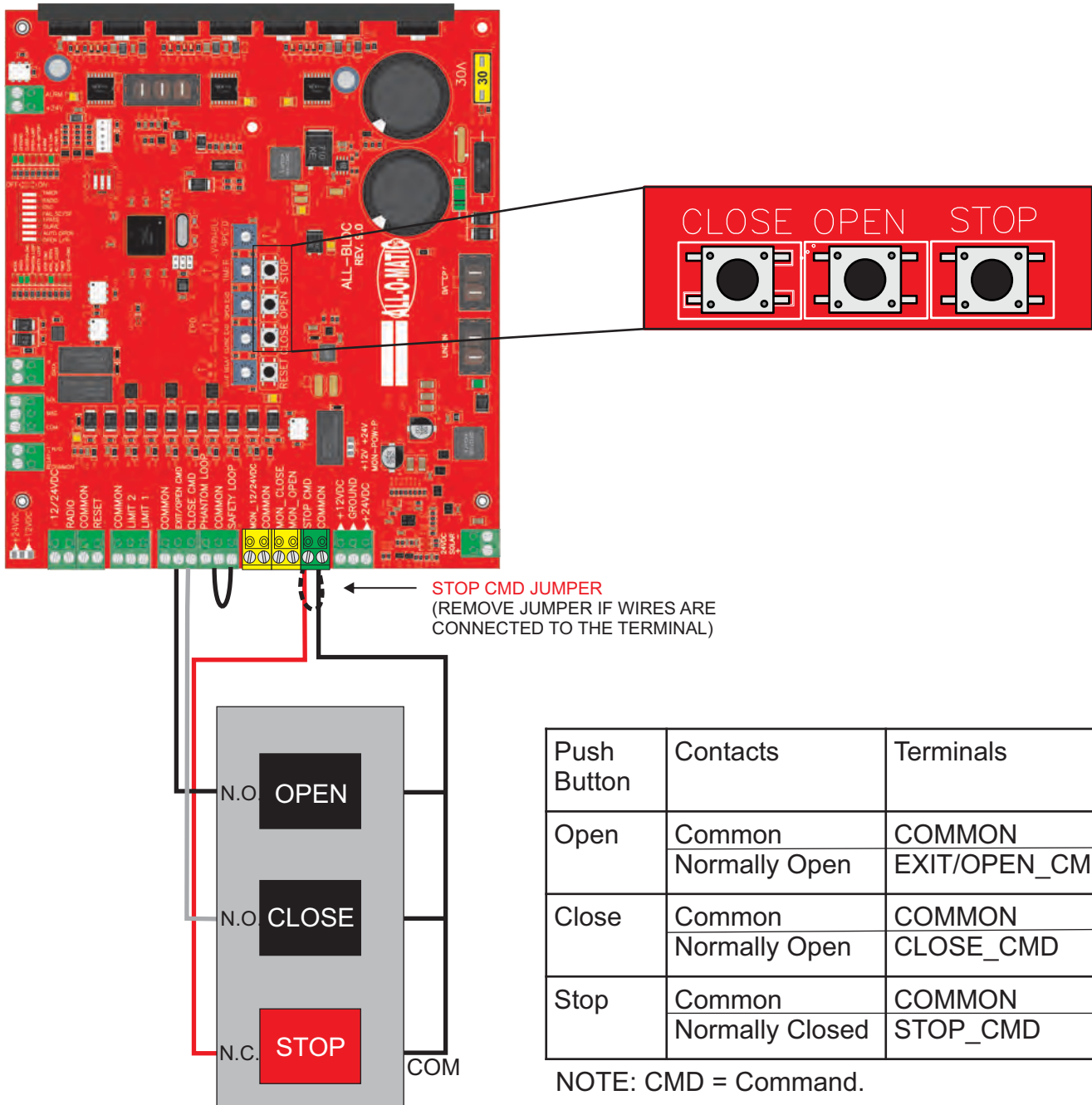

MASTER/SLAVE CONNECTION

BEFORE CONNECTING MASTER/SLAVE COMMUNICATION WIRES, TAKE THE FOLLOWING STEPS:

- 1: Test and adjust the limit switches and ERDs for each operator as stand alone machines.
- 2: Once the machines have been adjusted, turn SLAVE dip switch "ON" to the slave board.
Press the RESET button on the slave board.
- 3: Connect the master/slave communication wires to "DATA -" and "DATA +".
The "M/S LINK" LED should be "ON" on both machines.
- 4: Connect all accessories to the master operator. Accessories installed on the slave operator **will not work**.



NOTE: We now offer a new solution for applications where it is difficult or impossible to run wires across the driveway for dual gate M/S communication.

The new WiSe module is a wireless solution that can be used in place of running hard wires for communication.

Installation is quick and easy. All you need are power and DATA+ / DATA- connections. There is no programming or set up on the board necessary. Just connect the wires and it will automatically link up.

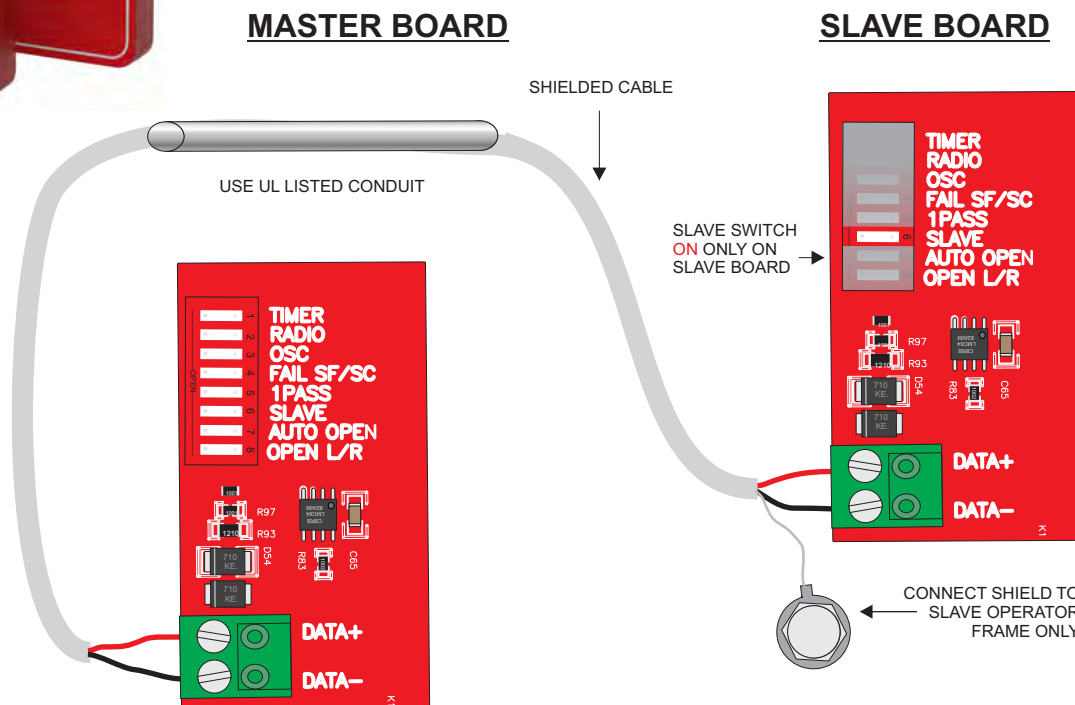

MAGNETIC/SOLENOID LOCK CONNECTION

Magnetic lock installation requires a step down transformer with the appropriate voltage for the specific lock accessory. Most operators include a 120VAC outlet for the step down transformer. The **SL-45DC** does not include a 120VAC outlet.

Connections: Plug the lock device transformer to the 120VAC outlet plug.

For Magnetic Lock: Wire nut one wire from transformer directly to one wire of the magnetic lock. The other wire from transformer will be connected to the board relay plug **COM** input and the other wire of the magnetic lock connects to the board **MAG** relay output. See illustration below.

For Solenoid Lock: Wire nut one wire from transformer directly to one wire of the solenoid lock. The other wire from transformer will be connected to the board relay plug **COM** input and the other wire of the solenoid lock connects to the board **SOL** relay output. See illustration below.

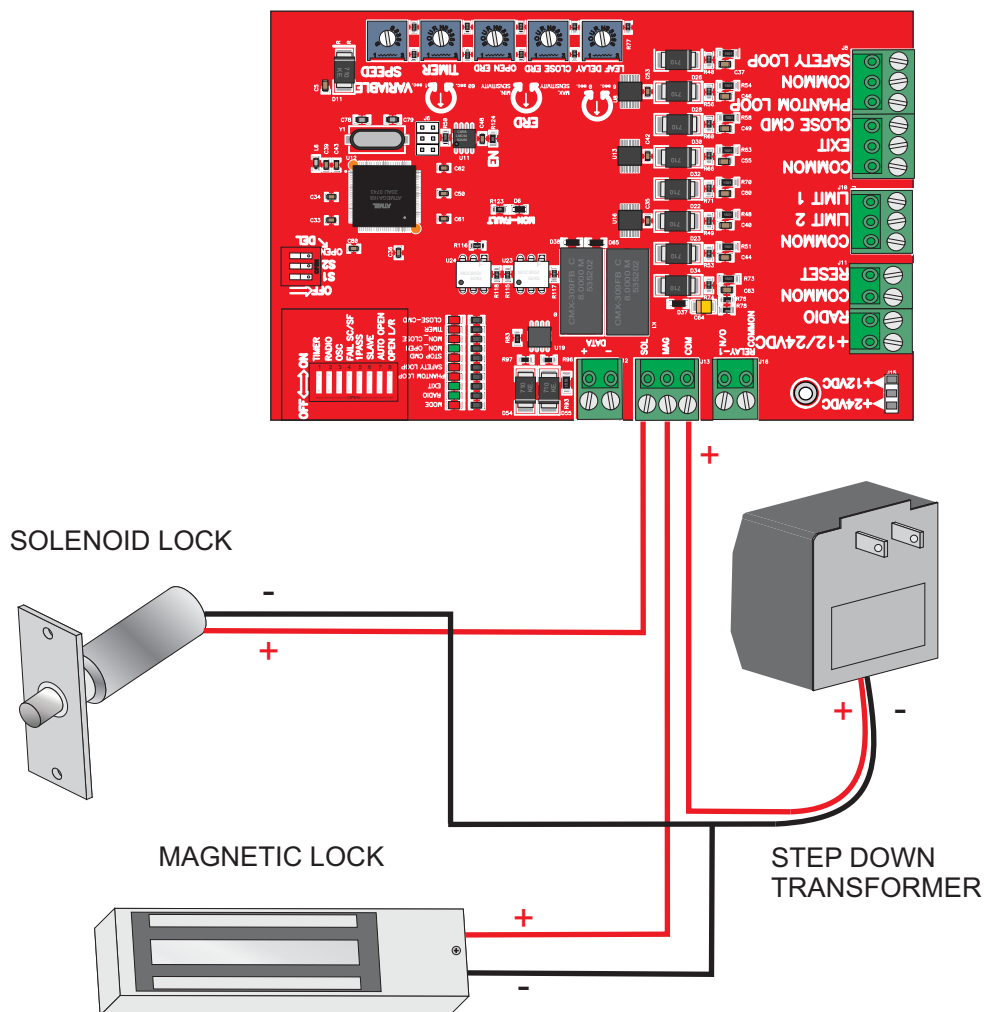

RADIO RECEIVER CONNECTION

There are two types of receivers: 3-wire and 4-wire:

3 wire receivers can mount on the radio receiver terminal strip located outside of the control box.

For 4 wire receivers, connect the relay contact wires to terminals 1 (COMMON) and 2 (RELAY/RADIO) on the receiver terminal strip located outside of the control box (one wire on each terminal). For power connect the black(negative) wire to terminal 1 (COMMON) and the red (positive) wire to terminal 3 (+12/24VDC) on the receiver terminal strip as shown below.

RADIO dip switch ON allows the radio receiver to override the automatic close timer. See TIMER adjustment page for more details.

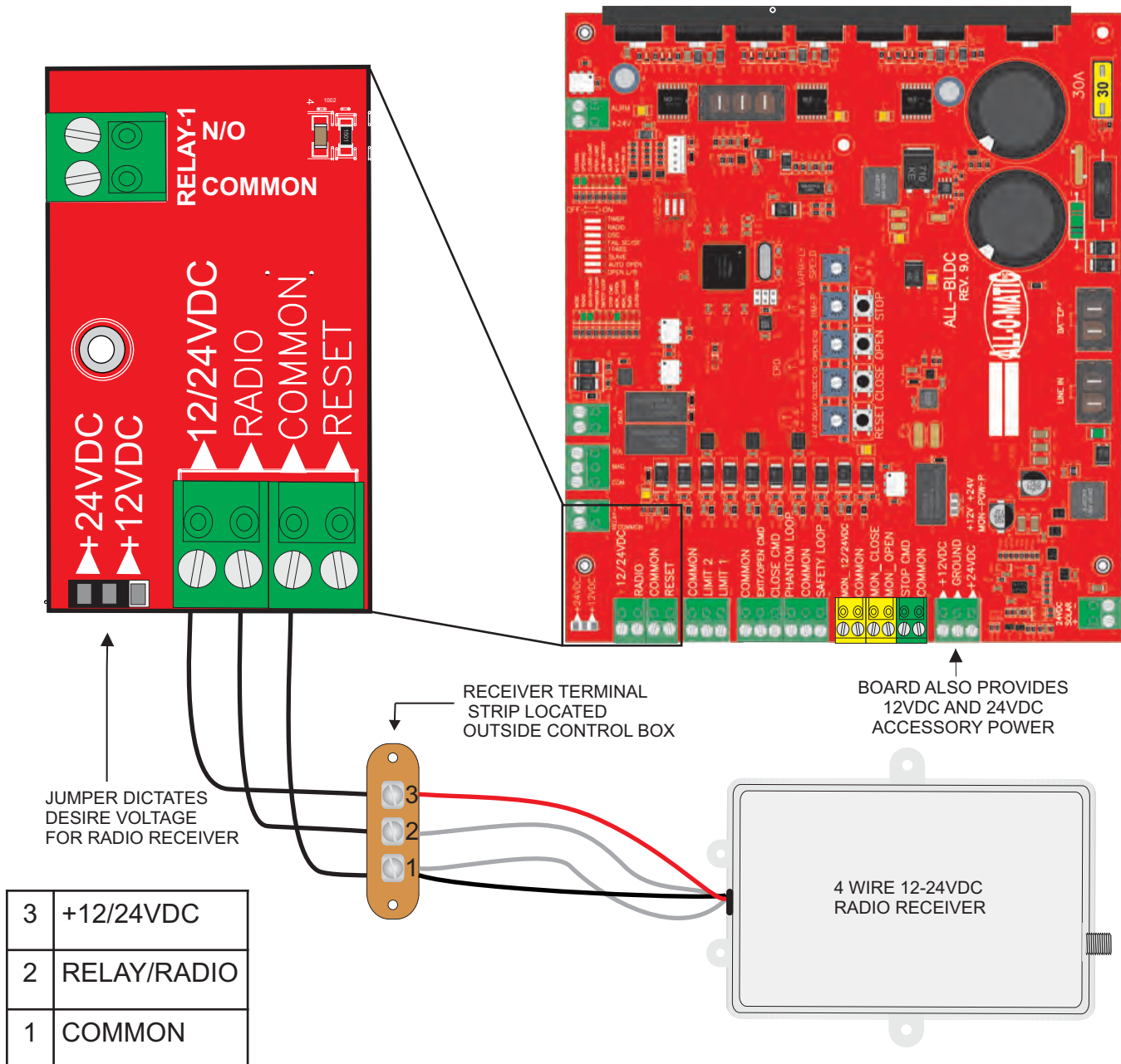

SOLAR PANEL CONNECTION

The solar panel input requires a minimum of a 24VDC, 40 Watt panel. The charging circuit is limited by 80 watt maximum. With (2) 14Ah, 12VDC batteries, a receiver and (2) monitored entrapment devices connected, this set up will provide about 10 cycles/day.

Be sure to use the SOLAR input for solar panels. The on board solar battery regulator offers a MPPT feature that makes it more efficient than other types of regulators.

For a solar installation, upgrade the batteries according to usage. When the application requires more than 80 watts of solar power, an external charge controller regulator is necessary. See next page for external solar system.

For information on solar applications (solar panel sizes, battery size, etc.), please call All-O-Matic.

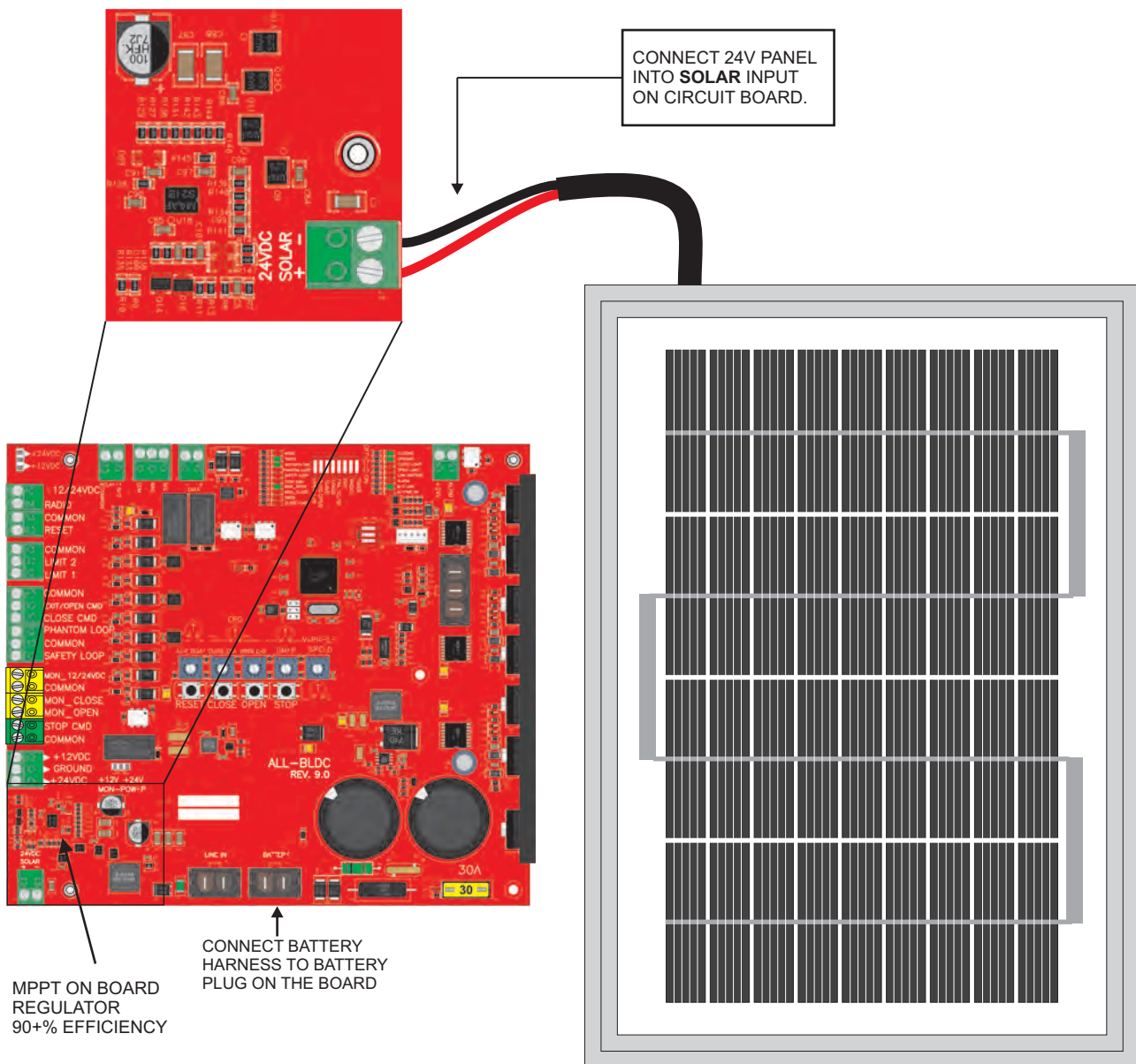

EXTERNAL SOLAR SYSTEM INSTALLATION

When using an external solar package, connect batteries straight into the **BATTERY** input. The batteries will need to be upgraded to meet application requirements. See wiring below.

For information on solar applications (solar panel sizes, battery size, etc.), please call All-O-Matic.

IMPORTANT: When more than two solar panels are needed, special wiring precautions must be taken to prevent damage to batteries and/or charge controller regulator. If the panels are 12VDC they must be wired in series to make 24VDC. If 24VDC panels are used they must be wired in parallel.

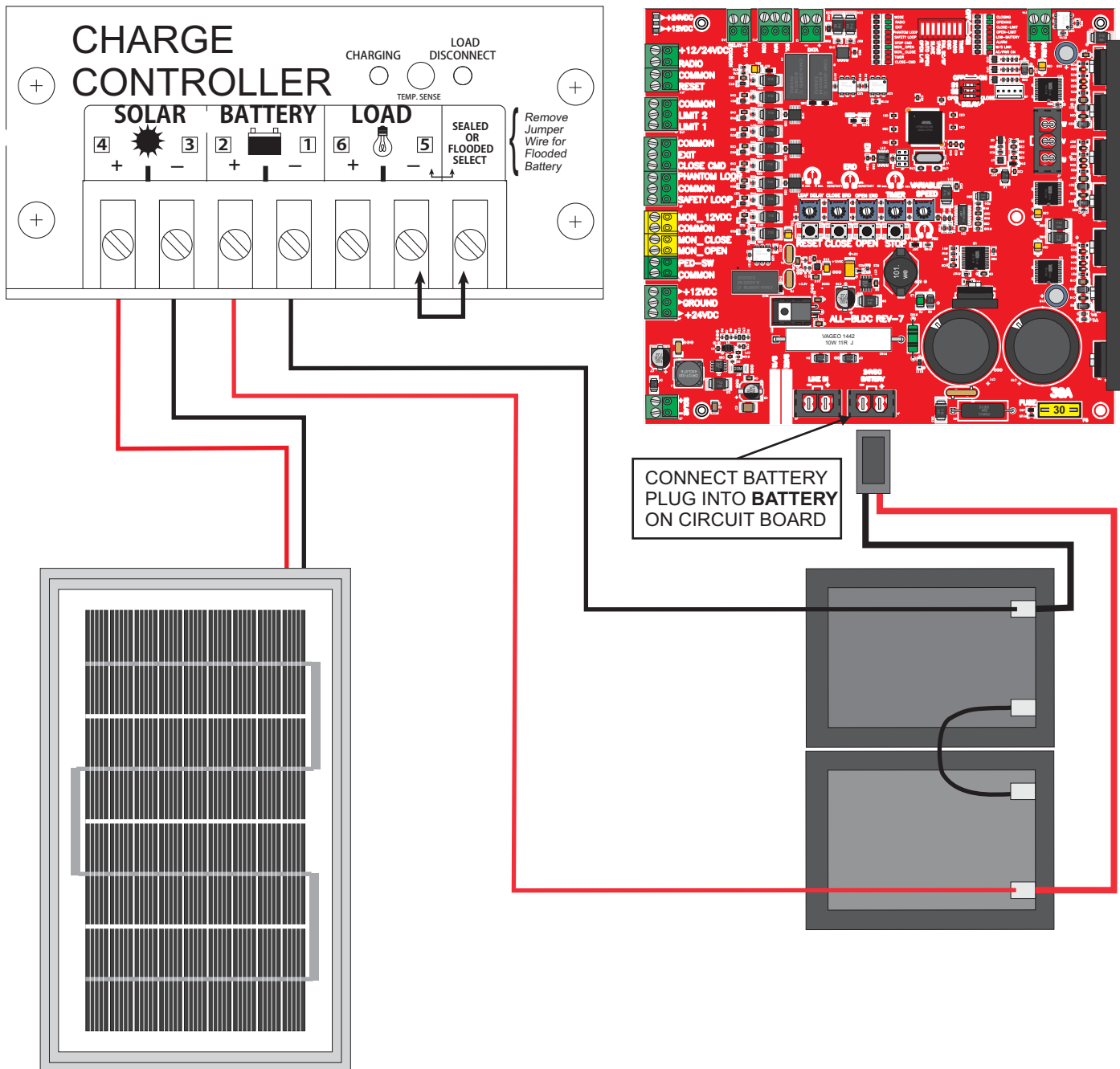

EMERGENCY RELEASE FOR SL-45 DC

Procedures to manually open the SL-45 DC:

1. Remove operator cover.
2. Turn both power and battery switches OFF.
- 3.. Push gate open

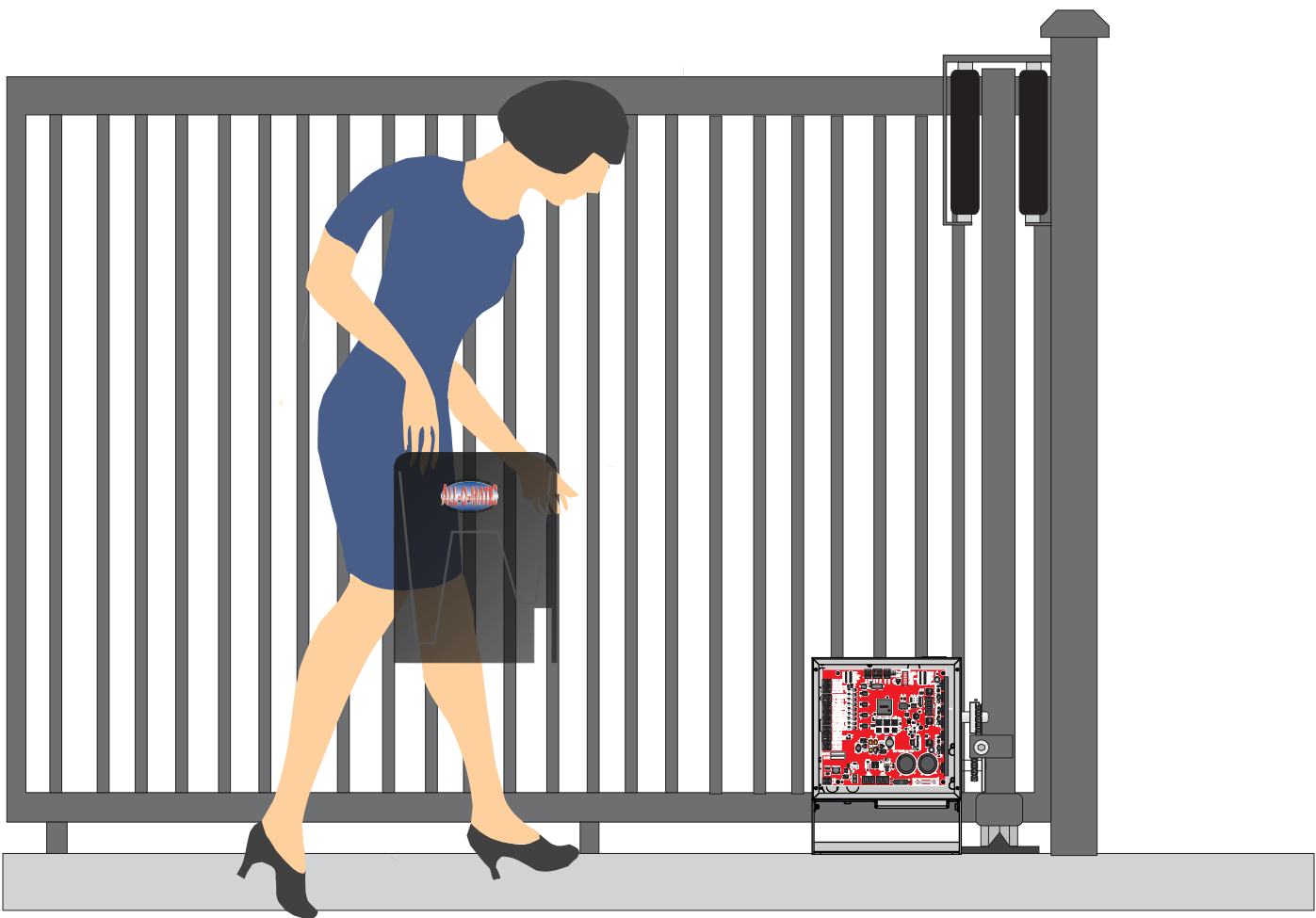

EMERGENCY RELEASE FOR SL-90 DC, SL-100 DCFP, AND SL-150 DC

Procedures to manually open the SL-90 DC, SL-100 DCFP, and SL-150 DC:

1. Turn operator power "OFF"
2. Push foot pedal down and move to the side to keep pedal in down position
3. Push gate open

NOTE: These operators are equipped with a kill switch on foot pedal. Even if operator power is turned ON, the operator will not run while the foot pedal is down. The **STOP CMD** LED will indicate the foot pedal is pressed down.



PAD LOCK TABS

Lock tabs are provided in the hardware bag for the SL-45 DC only.

Remove bolt and install lock tabs for cover to secure with a pad lock.

Lock kits are available for purchase for the SL-90 DC, SL-100 DC, SL-100FP DC, and SL-150 DC.

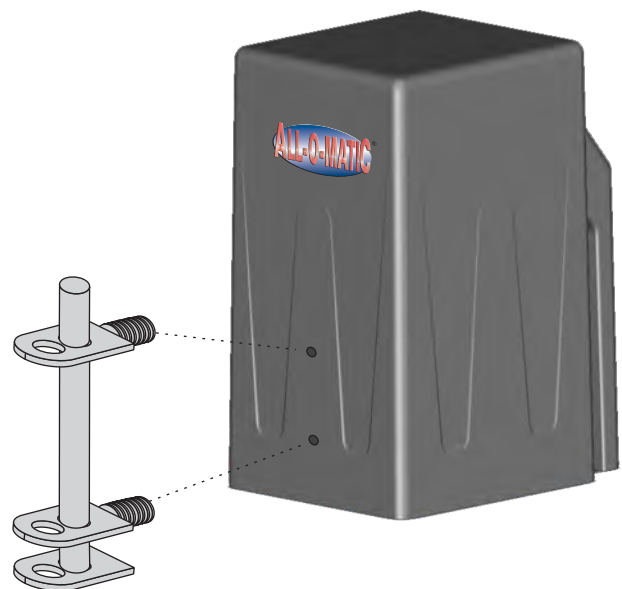
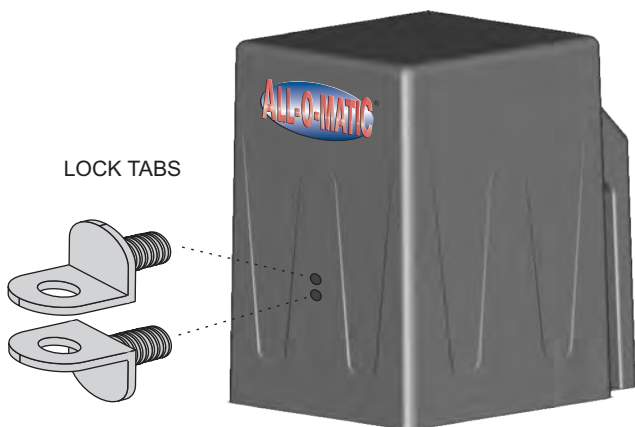
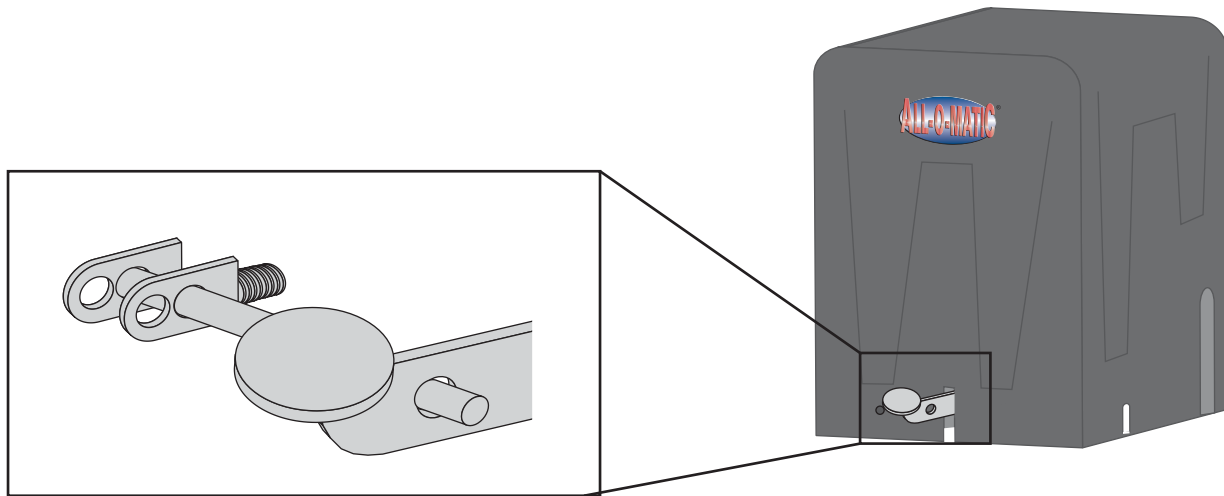

WARRANTY AND RECORD

MANUFACTURER'S LIMITED WARRANTY

ALL-O-MATIC INC warrants the following gate operators (SL-90 DC, SL-100 DC[FP], SL-150 DC) for a period of five (5) years in commercial installations and for a period of seven (7) years in residential installations. The SL-45DC will have warranty period of five (5) years in residential installations. The above operators, within their warranty period, are to be free from defects in circuitry, motor, gearbox and workmanship. This warranty begins from the date of purchase to the original owner. Warrantor will repair or, at its option, replace any device which it finds to require service. This device must be sent to the warrantor at the consumer's expense to:

**ALL-O-MATIC INC.
7820 GLORIA AVE.
VAN NUYS, CA 91406**

The warrantor will return the repaired or replaced unit to the customer at the consumer's expense. Labor charges for dealer service or replacement are the responsibility of the owner. These warranties are in lieu of all other warranties either expressed or implied, and ALL-O-MATIC INC shall not be liable for consequential damage. All implied warranties of merchantability and or fitness for a particular purpose are hereby disclaimed and excluded. This limitation is not valid in jurisdictions which do not allow limitation of incidental or consequential damages or limitation of warranty periods. In order to obtain this policy, please complete the registration card and send it by mail within 30 days of purchasing from ALL-O-MATIC INC. or your installer. If product is not registered, only a one year warranty on all parts will be provided.

CUSTOMERS RECORD

Customer Name _____

Address _____

Purchased from (Installation Co.) _____

Date ___ / ___ / _____

Model Number _____

Serial Number _____ - _____

OPERATOR CURRENT DRAW AND VOLTAGE DROP CHARTS

DC GATE OPERATORS	CURRENT DRAW @ 115VAC	CURRENT DRAW @ 220VAC
SL-45DC	2 AMPS	1 AMP
SL-90DC	5 AMPS	3 AMPS
SL-100FP DC	6 AMPS	3.5 AMPS
SL-150DC – ½ HP	4 AMPS	2 AMPS
SL-150DC – 1 HP	8 AMPS	4.5 AMPS
SL-175DC	9 AMPS	5 AMPS
TORO 24	4 AMPS	2 AMPS
SW-300DC	6 AMPS	3.5 AMPS
SW-325DC	6 AMPS	3.5 AMPS
SW-350DC – ½ HP	6 AMPS	3.5 AMPS
SW-350DC – 1 HP	8 AMPS	4.5 AMPS
SW-375DC	8 AMPS	4.5 AMPS
OH-200DC	6 AMPS	3.5 AMPS

Max Wire Feet @ 120 Volts, 1 Phase, 2% Max Voltage Drop						
Amps	Volt- Amps	#14	#12	#10	#8	#6
1	120	450	700	1100	1800	2800
5	600	90	140	225	360	575
10	1200	45	70	115	180	285
15	1800	30	47	75	120	190
20	2400	œ	36	57	90	140
25	3000	œ	œ	45	72	115
Amps	Volt- Amps	#4	#2	1/0	2/0	3/0
1	120	4500	7000	œ	œ	œ
5	600	910	1400	2250	2800	œ
10	1200	455	705	1100	1400	1800
15	1800	305	485	770	965	1200
20	2400	230	365	575	725	900
25	3000	180	290	460	580	720

Max Wire Feet @ 240 Volts, 1 Phase, 2% Max Voltage Drop						
Amps	Volt- Amps	#14	#12	#10	#8	#6
1	240	900	1400	2200	3600	5600
5	1200	180	285	455	720	1020
10	2400	90	140	225	360	525
15	3600	60	95	150	240	350
20	4800	œ	70	110	180	265
25	6000	œ	œ	90	144	210
Amps	Volt- Amps	#4	#2	1/0	2/0	3/0
1	240	9000	œ	œ	œ	œ
5	1200	1750	2800	4500	5600	7000
10	2400	910	1400	2200	2800	3600
15	3600	605	965	1500	1900	2400
20	4800	455	725	1100	1400	1800
25	6000	365	580	920	1100	1440

TECHNICAL TIPS

Board says “opening/closing”, but the gate does not move.

- Check the fuse on the circuit board. If the fuse is blown (the LED next to the fuse will be on), replace the fuse. If the gate goes back into operation, make sure that the gate is not binding or hitting either of the positive stops and/or catch. If the fuse blows again (immediately), the impact has shorted the transistor(s) on the board and the board will need to be repaired.
- Check the motor harness. Make sure the connector is in tight and that none of the wires are loose.

Radio and Monitored Power jumpers

- Jumpers come on 12VDC from the factory. The radio jumper is located on the top left of the board. The monitored power jumper is located to the right of the “12VDC/GROUND/24VDC” green terminal, underneath the relay. (NOTE: The 1090 Multicode receiver must have 24VDC to work)

The 10 amp fuse on the EMI board keeps blowing

- Turn off the power, disconnect one of the white wires from the bridge rectifier and replace the fuse. Turn the power back on. If the fuse does not blow immediately, the bridge rectifier needs to be replaced.
- If the fuse blows with the white wire disconnected, make sure the MOVs (blue wafer components) or traces on the back of the EMI board have not burned. Check voltages from the EMI board, transformer, bridge rectifier, etc. to see where the voltage issue is occurring.

Learning the slow down for the open and close limits

- Get the gate in the fully open or close position. Press and release “RESET” on the circuit board. Run the gate one full cycle (full open and full close) without interruption. The first cycle may run slower while the board is learning and will run full speed the second cycle.

The gate is running slow

- Make sure that the variable speed potentiometer is at 100%.
- Follow the steps above to learn the slow down on the board.

Technical Support

- Technical Support is available in English and Spanish, Monday-Friday from 7:00 am to 3:30 pm PST
- Call us at (818) 787-1988

Advance Replacement/ Repair and Return Policy

- We advance replace items within the first (2) years of the operator date. In order to get an advance replacement, you must call our tech support and troubleshoot from the job site. If the item is determined to be defective, we will issue the technician a RMA number to give to the distributor. The distributor will send us a PO for the advance replacement item. Please note that any warranty item over (2) years will be repair and return only.
- We repair defective boards (including boards out of warranty) at no charge, provided that the board components are still available (applicable to boards over (15) years old) and that the board was not damaged by a power surge or has evidence of water damage. You can send the board in directly to us or send it to us through your distributor. We do our best to get the boards out 1-2 days after we receive it.

ALL-O-MATIC[®]

MANUAL



UL 325 & UL991
COMPLIANT

CANADA
CSA C22.2
COMPLIANT